

Operating Instructions

Bluetooth Handheld Scanner Zone 2/22 incl. supply

SD164BTII^{ex}
Type SD.12F.0000.01

SD264BTII^{ex}
Type SD.12G.0000.00

SDUSBII^{ex} / SDRS232II^{ex}
Type SD.121.000*.0*



Date: 18.09.2025

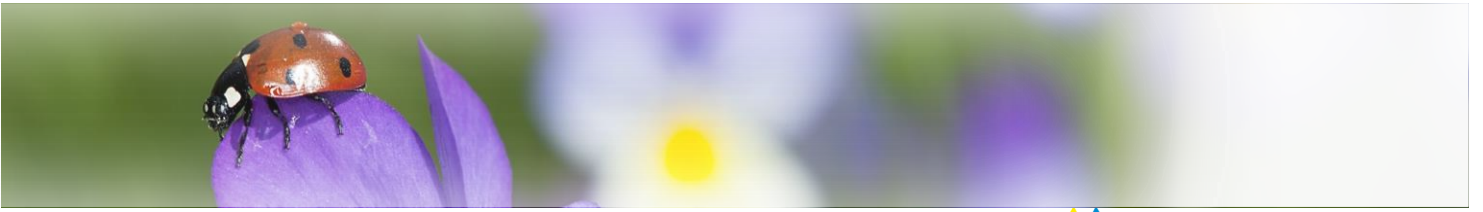

sigmann  DELTA



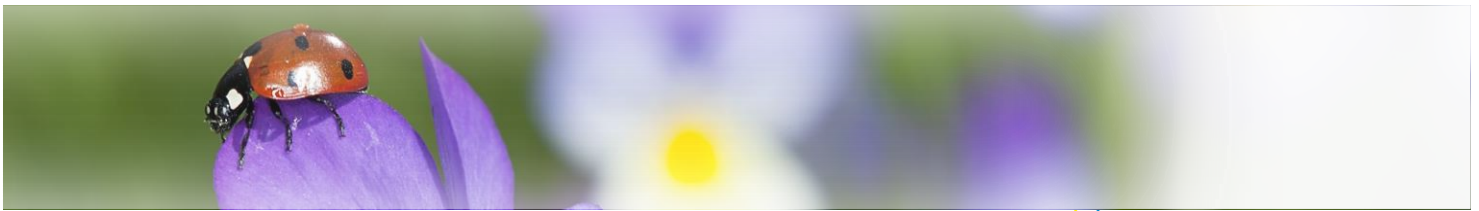
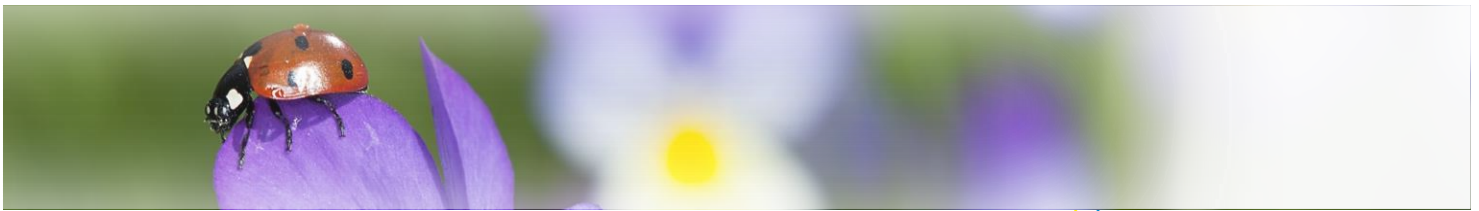
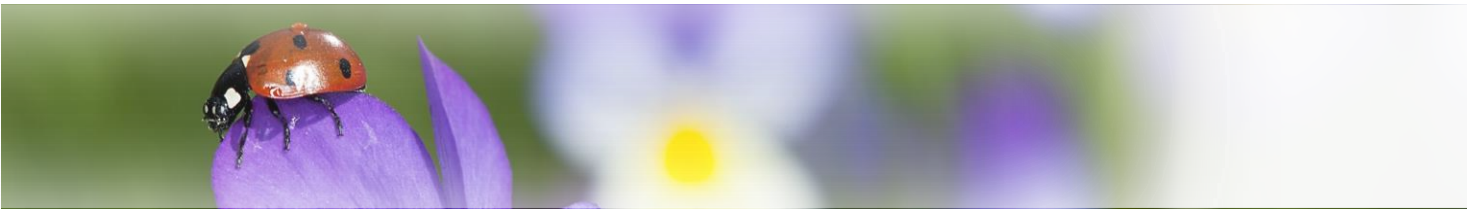

Table of contents

1	Product range Bluetooth handheld scanner Zone 2/22	5
2	Scanner overview	6
3	Compatible Scanner and base station zone 2/22 overview	7
4	Important notes on the Operating Instructions	8
	4.1. Safety Information	8
	4.2. Notes to the Operating Instructions	9
	4.3. General Notes of caution	10
5	Product information SD164BTII^{ex} Type SD.12F.0000.01	12
	5.1 Explosion Protection	12
	5.2 Technical Data Bluetooth scanner zone 2/22	12
	5.3 Technical Data Base station zone 2/22	13
	5.4 Technical Data Supply zone 2/22	14
	5.5 Type Numbers - 1D Bluetooth scanner SD164BTII ^{ex}	16
	5.6 Serial numbers	16
	5.7 Application	16
6	System design - 1D Bluetooth handheld scanner SD164BTII^{ex}	17
	6.1 System design 1 with SDUSBI ^{ex} in hazardous area	17
	6.2 System design 1 with SDRS232II ^{ex} in hazardous area	18
	6.3 System design 2 with base station in non-hazardous area	19
7	Product information SD264BTII^{ex} Type SD.12G.0000.00	21
	7.1 Explosion Protection	21
	7.2 Technical Data Bluetooth scanner zone 2/22	21
	7.3 Technical Data Base station zone 2/22	22
	7.4 Technical Data Supply zone 2/22	23
	7.5 Type Numbers - 2D Bluetooth scanner SD264BTII ^{ex}	25
	7.6 Serial numbers	25
	7.7 Application	25



8	System design - 2D Bluetooth handheld scanner SD264BTII^{ex}	26
8.1	System design 1 – with SDUSBI ^{ex} in hazardous area	26
8.2	System design 1 – with SDRS232II ^{ex} in hazardous area	27
8.3	System design 2 – with base station in non-hazardous area	28
9	Cable range in system design	30
9.1	Cable range in system design 1	30
9.2	Cable range in system design 2	31
10	Dimensions Supply	32
10.1	Dimensions supply cable SDUSBI ^{ex} / SDRS232II ^{ex}	32
10.2	Cable length of the supply cable	33
11	Step-by-step guide on installation and operation	34
11.1	General connection of Bluetooth handheld scanner for system design 1 & 2	34
11.2	Using base station zone 2/22 for system design 1	35
11.3	Using non ex base station for system design 2	36
11.4	Pin assignment supply cable SDRS232II ^{ex} (SD.121.0002.01) with RS232 interface	37
11.5	Pin assignment supply cable SDUSBI ^{ex} (SD.121.0001.01) with USB interface	45
12	Attachment	41
12.1	Type examination certificate zone 2/22	41
13	Contact	58



1 Product range Bluetooth handheld scanner Zone 2/22

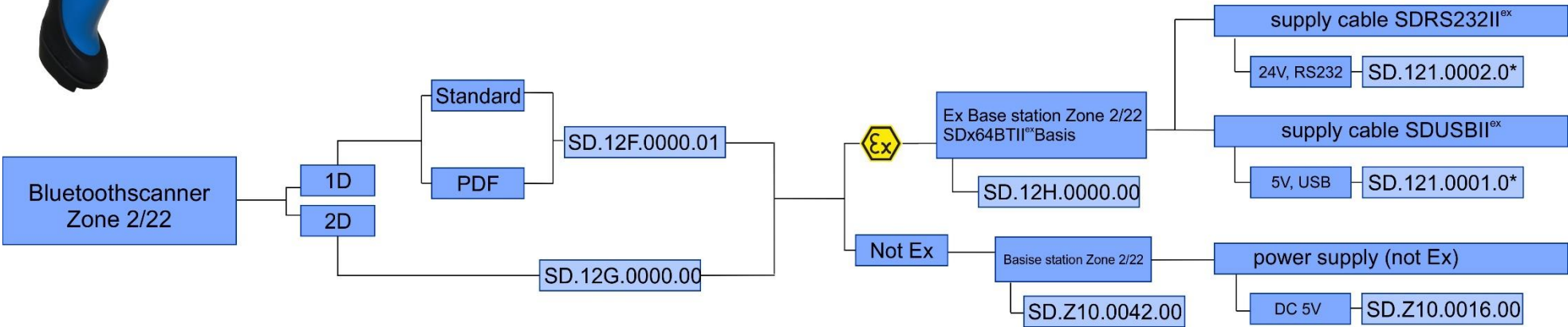

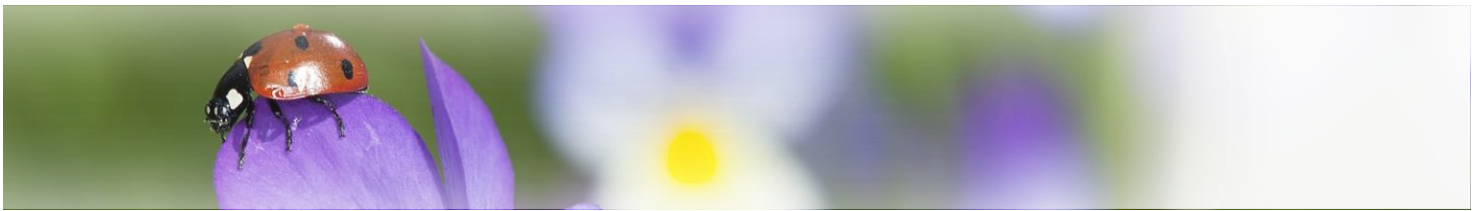

2 Scanner overview

	Bluetooth	1D	PDF	2D
SD161BTII ^{ex}	✓	✓	✗	✗
SD161BTII ^{ex} PDF	✓	✓	✓	✗
SD261BTII ^{ex} 3rd	✓	✓	✓	✓
SD164BTII ^{lex}	✓	✓	✓	✗
SD264BTII ^{ex}	✓	✓	✓	✓

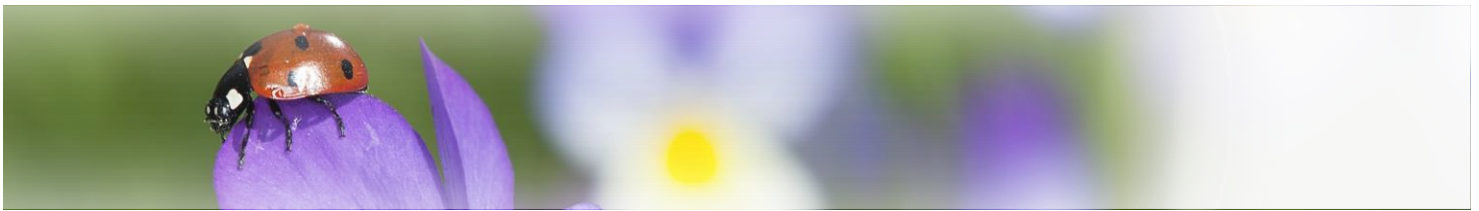

3 Compatible Scanner and Base station zone 2/22 overview

Bluetooth hand-held scanner Zone 2/22	Typenumber Bluetooth handheld scanner Zone 2/22	Typenumber Base station/ Charging –station Zone 2/22	Description	Connection cable RS232 / USB	Supply
SD161BTII ^{ex} SD261BTII ^{ex} 3rd	SD.128.0000.0* SD.124.0000.00	SD.127.0000.00 SD.127.0000.01	Base station zone 2/22 for hazardous area	SD.Z10.0010.0* SD.Z10.0011.0*	SDRS232II ^{ex} with RS232-connection: SD.121.0002.01
SD164BTII ^{ex} SD264BTII ^{ex}	SD.12F.0000.01 SD.12G.0000.00	SD.12H.0000.00			SDUSBI ^{ex} with USB-connection: SD.121.0001.01
SD161BTII ^{ex} SD261BTII ^{ex} 3rd	SD.128.0000.0* SD.124.0000.00	SD.Z10.0037.00	Base station for non hazardous area	SD.Z10.0012.0* SD.Z10.0013.0*	separate 5V-power supply SD.Z10.0016.00
SD164BTII ^{ex} SD264BTII ^{ex}	SD.12F.0000.01 SD.12G.0000.00	SD.Z10.0042.00			or connection cable RS232 or USB
SD161BTII ^{ex} SD261BTII ^{ex} 3rd	SD.128.0000.0* SD.126.0000.00	SD.Z.10.0036.00	Charging station for non hazardous area without Bluetooth function	SD.Z10.0013.0*	separate 5V-power supply SD.Z10.0016.00
SD164BTII ^{ex} SD264BTII ^{ex}	SD.12F.0000.01 SD.12G.0000.00	SD.Z10.0036.00			

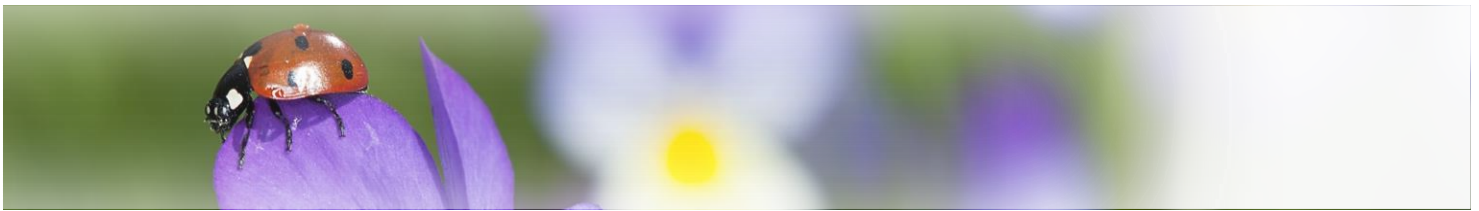

4 Important notes to the Operating Instructions

4.1 Safety information

Warnings are highlighted by a special symbol and a different font colour:



Danger

**Non-compliance may result in life-threatening situations.
This warning must be heeded.**



Warning

This type of warning concerns dangerous situations that may result in minor injuries.



Info

Important and helpful notes and information.

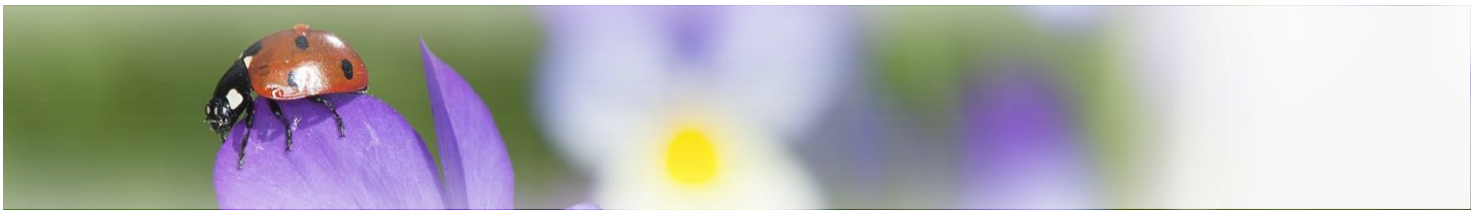

4.2 Notes on the Operating Instructions

Before starting up the equipment please read the Manual carefully.

The Operating Instructions contain important information on functionality as well as safety rules. If these are not heeded, normal operations within hazardous areas cannot be guaranteed.

The notes contained in this manual are important for starting up and operating the product.

These instructions may be updated at any time. Sigmann DELTA GmbH reserves the right to make changes to this document.

Before using the product, users must ensure that they have the most up-to-date version of the operating instructions. To be sure this is the case, please check Sigmann DELTA's website at www.Sigmann-DELTA.de or contact one of the company's staff.

The drawings contained in these operating instructions are for illustration purposes only and may differ somewhat from the actual design.



No changes may be made to the device that were not intended or approved by Sigmann DELTA.

If the Bluetooth handheld scanner zone 2/22 is not used properly, the operating permission for hazardous areas may lapse for the device in question.

Non-adherence to the instructions will void any warranty.



For the full commission of the SD164BTII^{ex} and SD264BTII^{ex} bluetooth handheld scanner zone 2/22 the programming information contained in the manual issued by SICK AG (www.SICK.com) are also required.

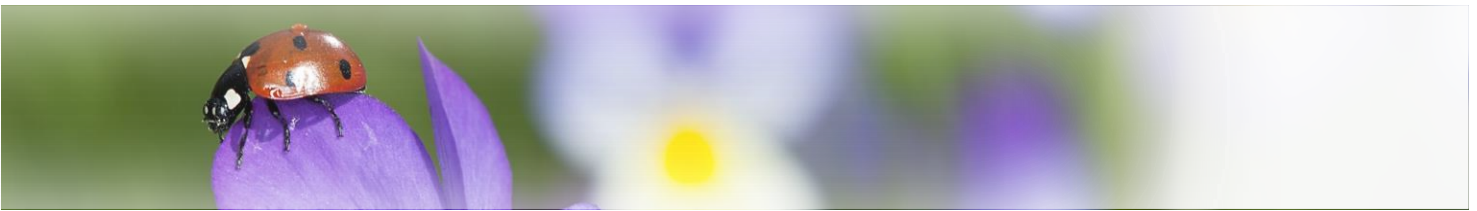

4.3 General notes of caution

Caution / Notes



- The devices may only be operated when fully assembled.
- In hazardous areas the devices must not be wiped or cleaned with a dry cloth.
- The device must be switched off immediately if it is likely that as a consequence of damaging impact or general peculiarities the device can no longer be safely operated. (e.g. ingress of water or other fluids, temperatures outside of the specified range,...)
- General statutory requirements or health and safety rules and accident prevention guidelines and environmental laws must be adhered to (e.g. the German Occupational Health and Safety regulation).
- Users must not open the device.
- Users must not make any changes to the device. Components may not be exchanged or replaced. If non-specified components are used, explosion protection is no longer guaranteed.
- Ensure safe handling with firm footing and sufficient room for movement.
- If the enclosure is in any way damaged the device must be removed from the hazardous area immediately.
- In accordance with IEC 60079-19 and IEC 60079-17, operators of electrical installation in hazardous areas are obliged to have them serviced by qualified electricians.
- Do not insert any sharp objects into the enclosure or any other openings of the handheld barcode scanner. Any openings at the device may not be covered or blocked.
- The device and any accessories must be properly disposed of, i.e. as legally specified, for example by a certified company.

Notes on installation

- Electrical plants are subject to certain regulations concerning installation and operation (e.g. RL 2014/34/EU, or the national rules such as IEC 60 079-14 and VDE 0100).
- In the hazardous area it is the operator's responsibility to carry out any repair and maintenance in compliance with applicable rules.

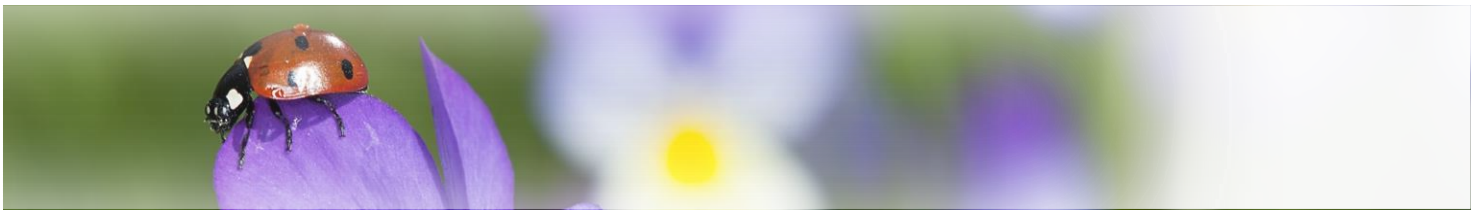

**Caution
on laser devices**



Devices fitted with laser fall under standards US 21 CFR 1040.10 and EN 60825-1. The laser's classification is stated on a plate affixed to the device. Class 1 lasers are deemed inherently safe during normal use, but users must not look directly into the light source. The following declaration is required by American and international laws:

Usage of control elements, adaptations or the use of procedures that differ from these instructions may result in a dangerous exposure to laser beams.

Class 2 lasers use a visible low-voltage LED. As with any source of bright light, such as the sun, the user should avoid looking directly into the light. Brief exposure to a class 2 laser is deemed not dangerous.

Maintenance

Provided the device is operated and assembled according to instructions and the ambient requirements are being met continuous maintenance is not necessary.

Servicing

Operators of electric equipment in hazardous areas are obliged to have them serviced by qualified electricians (IEC 60079-19 and IEC 60079-17).

Repairs

Repairs may only be carried out by the manufacturer or by persons trained and commissioned for this purpose by the manufacturer.

The device is closed ex-factory. It may only be opened in the factory by specifically trained personnel.

Software installation

For instructions on how to install the software at the PC please refer to the manual issued by SICK AG.

Operation

Before operating the device you must ensure that all necessary components are available.

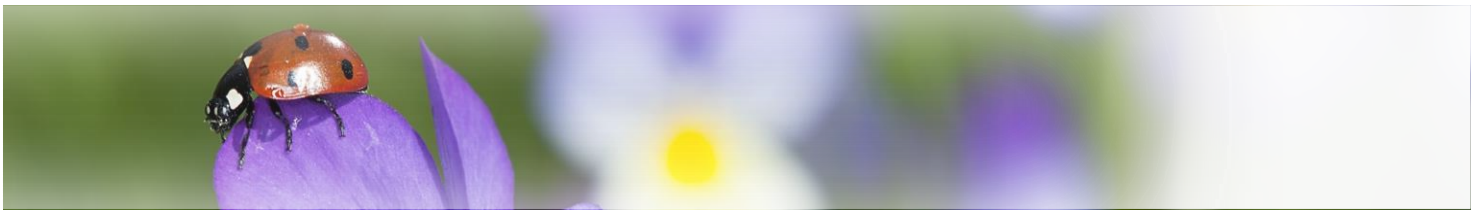





5 Product information - SD164BTII^{ex} Type SD.12F.0000.01

SD164BTII^{ex} 1D Bluetooth scanner zone 2/22



5.1 Explosion Protection

-  II 3G Ex ic IIB T4
-  II 3G Ex ic IIB T4 Gc
-  II 3D Ex ic IIIC T135°C
-  II 3D Ex ic IIIC T135°C Dc

Certification

IBExU 14 ATEX B012X

Manufacturer

Sigmann DELTA GmbH
Beim Braunstall 4
97980 Bad Mergentheim
Germany

5.2 Technical data

	With Battery Typ SD.Z10.0039.**	3,6 V; less than < 3.000 mAh
Technical data (Scanengine)	<ul style="list-style-type: none"> ● Light source: visible red light, 630nm ● Scanfrequenz: ≤ 500 Hz ● Reader distance: 50mm bis 800 mm (0,5mm) 	
Bluetooth handheld scanner zone 2/22	Bluetooth™ V4.0, 2,402 ... 2,4830 GHz	Up to 100 m (functional distance, free space)
Dimensions	104 x 76,3 x 176 mm (length x width x height)	
Ambient temperature	-20°C to +50°C	
Storage temperature	-40°C to +70°C	
Weight	220g, incl. battery	
Protection category	IP65	

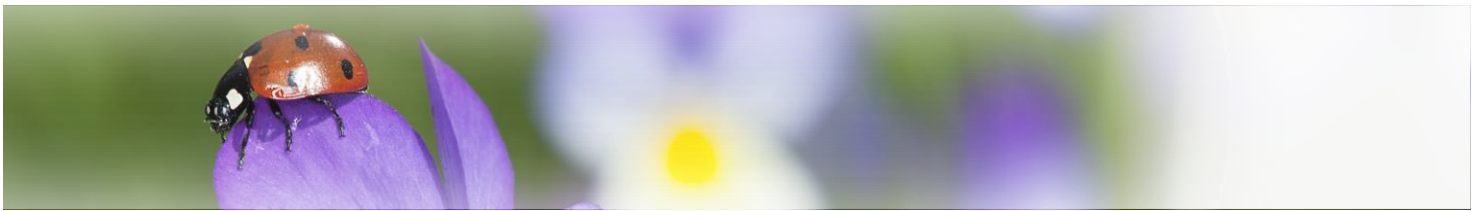

5.3 Technical data

Base charging station zone 2/22 SDx64BTII^{ex}Basis for SD164BTII^{ex} and SD264BTII^{ex}

**Ambient temperature
Base charging station
zone 2/22** -20°C to +50°C

**Storage temperature
Base-charging station
zone 2/22** -30°C to +70°C

**Bluetooth
Base charging station
zone 2/22** Bluetooth V 4.0 EDR, Class 1
2,4 ... 2,4830 GHz (ISM band)

**Bluetooth
Operational area** Up to 100 m (functional distance, free space),

Terminal assignment (Base charging station)	USB	RS 232
	USB/D+ green	RS 232-TXD white
	USB/D- white	GND brown
	GND black	+UB yellow
	+UB yellow	

**Operation
Base charging station zone
2/22** The base charging station zone 2/22 may be operated in hazardous areas. Its purpose is to receive data captured by the associated handheld scanner zone 2/22 (1D bar codes or 2D stacked codes) via bluetooth.

**Nominal values of the hazard-
ous base charging station up**

- maximum input voltage U_i : 6,5 V
- maximum internal inductance L_i : negligible small
- maximum internal capacitance C_i : < 231 μ F

**Nominal values
of the non-hazardous base
charging station**

Operating voltage $U = 5V$
Power requirement $I = 85 \text{ mA}$ in standby mode

5.4 technical data

Supply zone 2/22

Supply cable SDUSBII^{ex} SD.121.00001.01

dimension	80 mm x 40 mm x 20 mm (length x width x height)		
environmental temperature	-20°C to +50°C		
weight	approx. 250 g		
Non ex supply	voltage	U_N	5 V DC (USB)
Non-ex data	$\pm 5 \text{ V} / 68 \text{ mA}$		
Ex data	<ul style="list-style-type: none"> ● Max voltage $U_m = 253 \text{ V AC}$ ● Max voltage $U_o = 6,38 \text{ V DC}$ ● Max current $I_o = 1,071 \text{ A}$ ● Max power $P_o = 6,83 \text{ W}$ ● Max outer capacity $C_o = < 265 \mu\text{F} (L_o = 0)$ ● Max outer inductance $L_o = < 0,06 \text{ mH} (C_o = 0)$ 		
	Intrinsically safe circuit is grounded.		
Pionning non-ex data	Pin 3 Mini USB (grün): (D+)	$\pm 5 \text{ V} / 68 \text{ mA}$	
	Pin 2 Mini USB (weiß): (D-)		
Pinning ex data	coupling Pin 3 (green): (D+)	$U_i = 5,5 \text{ V DC}$	
	coupling Pin 2 (white): (D-)		
Connection cable	See pin assignment		

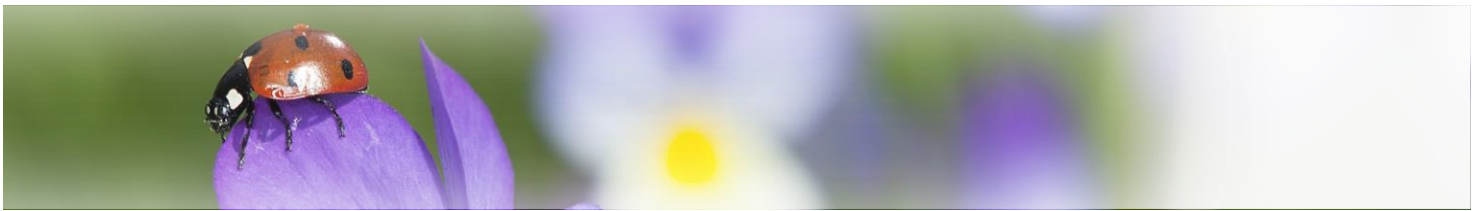

Supply cable SDRS232II^{ex} SD.121.00002.01

dimension	80 mm x 40 mm x 20 mm (length x width x height)		
environmental temperature	-20°C to +50°C		
weight	approx. 250 gr.		
Non ex supply	voltage	U_N	DC 10 ...30 V
	max. current	I_i	approx.. 100 - 200 mA (depending on the supply voltage)
Non-ex data	±12 V / 4mA bzw. +12/-7V / 4 mA		
Ex data	● Max voltage	U_m	= 253 V AC
	● Max voltage	U_o	= 6,38 V DC
	● Max current	I_o	= 1,071 A
	● Max power	P_o	= 6,83 W
	● Max outer capacity	C_o	= 280 μF ($L_o = 0$)
	● Max outer inductance	L_o	= 0,068 mH ($C_o = 0$)
	Intrinsically safe circuit is grounded.		
Pinning	RS232		RS422
non-ex data	Wire1: TxD (white) ±12V / 4mA		Wire3: T+ (yellow) +12/-7V / 4mA
	Wire2: GND (brown)		Wire4: T- (green)
Pinning ex data	coupling Pin 3 (white): (RxD)		$U_i = 5,5V$ DC
	coupling Pin 2 (brown): (GND)		
Connection cable	See pin assignment		

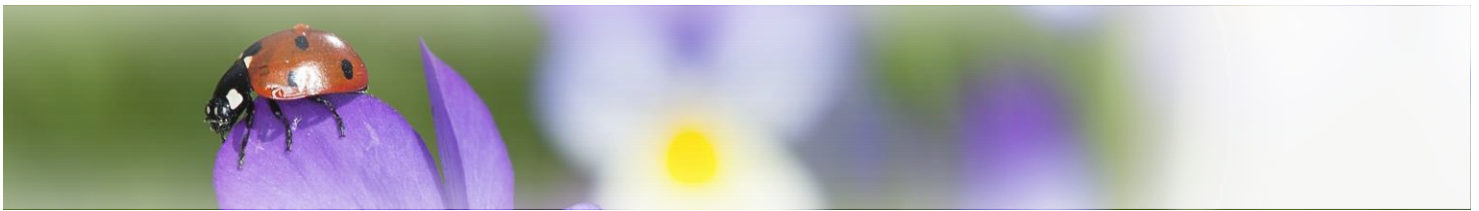

5.5 Type numbers - 1D Scanner SD164BTII^{ex}

SD 12F.0000.01

Standard 1D, Stacked PDF

Scanners for use with battery SD.Z10.0039.00

and a base charging station zone 2/22 of your choice (see below) and

- an explosion-protected connection cable
RS232 SD.Z10.0010.0* / USB SD.Z10.0011.0*
and a supply SDUSBI^{ex} SD.121.0001.01
SDRS232II^{ex} SD.121.0002.01
- or a non-explosion-protected connection cable
RS232 SD.Z10.0012.0* / USB SD.Z10.0013.0* (without supply)

SD.12H.0000.00

Explosion-protected base charging station zone 2/22

SD.Z10.0042.00

Non-explosion-protected base charging station

SD.Z10.0036.00

Non-explosion-protected charging station without Bluetooth

5.6 Serial numbers

Serial key:	year of manufacture	serial number
	2 numbers	4 numbers

Example: 240001

5.7 Application

The Bluetooth handheld scanner zone 2/22 is a handheld device.

Its purpose is the portable capture and direct transfer of data in hazardous areas. The device has been designed for use in hazardous areas zones 2 and 22.



The base charging station zone 2/22 may only be used in the hazardous area with one of the supplies listed under 5.4 .

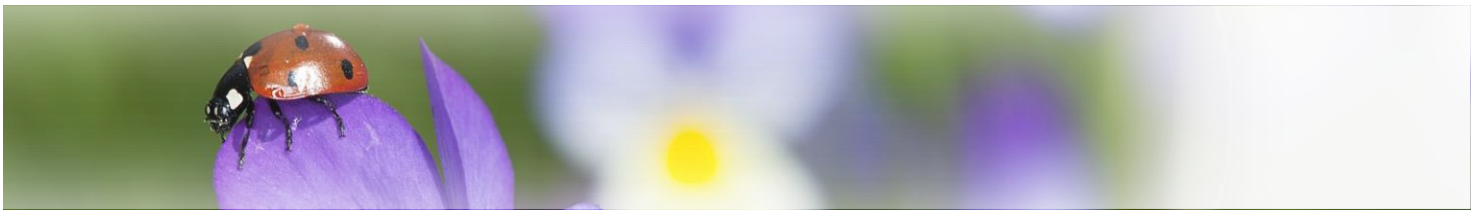

6 System design - 1D Bluetooth handheld scanner SD164BTII^{ex}

6.1 System design 1 with SDUSBII^{ex} in hazardous area

USB

Overview of the complete system design 1, Bluetooth handheld scanner zone 2/22 SD164BTII^{ex}

Design with base charging station zone 2/22 and supply cable SDUSBII^{ex} in hazardous area

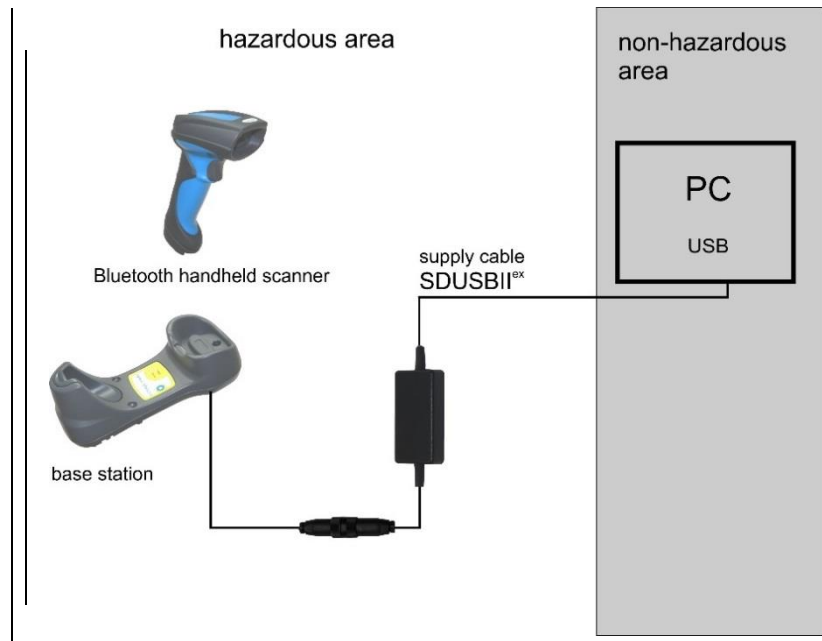

Description:

The Bluetooth handheld scanner zone 2/22 SD164BTII^{ex} (SD.12F.0000.01) is designed for use with battery (SD.Z10.0039.00) in hazardous areas. Normal operation requires a base charging station zone 2/22 (SD.12H.0000.00), a connection cable (SD.Z10.0011.0*) between the base charging station zone 2/22 and the supply cable SDUSBII^{ex} (SD.121.0001.0*). For connection to the PC in the non-hazardous area, a mini USB plug is attached to the USB-supply cable so that the cable can be routed through a cable gland.

For connection to the USB port of the PC, a corresponding adapter is included.

Connecting cables of the supply cable:

Data -/ Power supply cable USB 2.0

The Bluetooth handheld scanner zone 2/22, the base charging station zone 2/22 and the supply unit can be connected and operated in the hazardous area. The current rating of the connection cables must be checked before use.

The USB connection must be connected outside the hazardous area.



The warnings and notes of caution contained in these operating instructions and in the manual issued by SICK AG (www.SICK.com) must be adhered to.

6.2 System design 1 with SDRS232II^{ex} in hazardous area

RS232

Overview of the complete system design 1,
Bluetooth handheld scanner
zone 2/22 SD164BTII^{ex}

Design with base charging station
zone 2/22 and supply cable
SDRS232II^{ex} in hazardous area

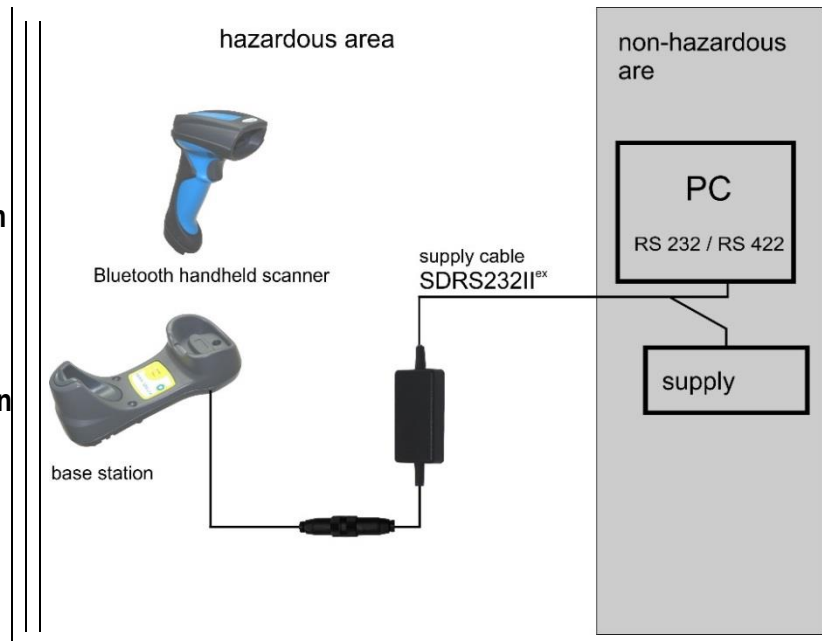

Description:

The Bluetooth handheld scanner zone 2/22 SD164BTII^{ex} (SD.12F.0000.01) is designed for use with battery (SD.Z10.0039.00) in hazardous areas. Normal operation requires a base charging station zone 2/22 (SD.12H.0000.00), a connection cable (SD.Z10.0010.0*) between the base charging station zone 2/22 and the supply cable SDR232II^{ex} (SD.121.0002.0*).

For connection to the RS232 port of the PC, a corresponding adapter is included.

Connection cables of the supply cable:

Data cable	RS232/RS422: 0,14 mm ² 2-wire
Supply cable	RS232/RS422: 0,14 mm ² 2-wire

The Bluetooth handheld scanner zone 2/22, the base charging station zone 2/22 and the supply unit can be connected and operated in the hazardous area. The current rating of the connection cables must be checked before use.

The RS232 connection must be connected outside the hazardous area.



The warnings and notes of caution contained in these operating instructions and in the manual issued by SICK AG (www.SICK.com) must be adhered to.

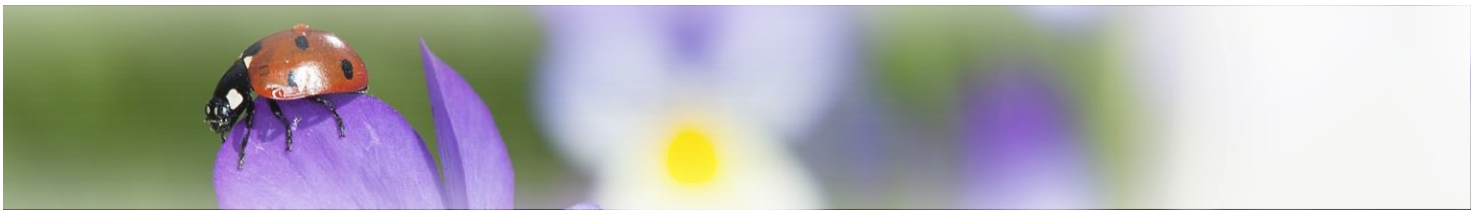

6.3 System design 2 with non ex base station in non-hazardous area

RS232

Overview of the complete system design 2,
Bluetooth handheld scanner
zone 2/22 SD164BTII^{ex}

Design with non-ex-base charging
station outside the hazardous
area

hazardous area



Bluetooth handheld scanner

non-hazardous area

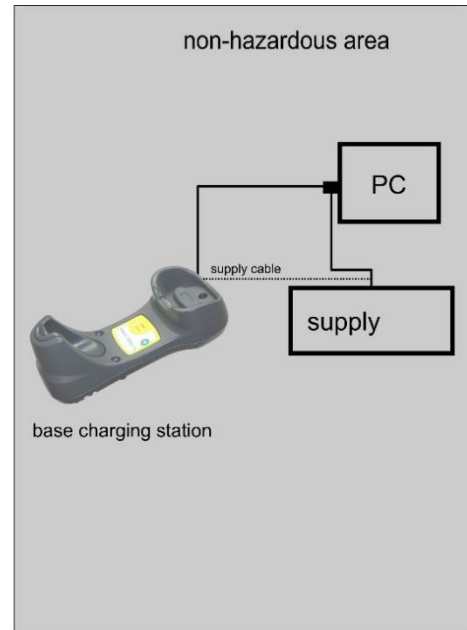

Description:

The Bluetooth handheld scanner zone 2/22 SD164BTII^{ex} (SD.12F.0000.01) can also be used separately in the hazardous area.

The base non-ex base station /charging station (SD.Z10.0042.00 / SD.Z10.0036.00) is operated in the non-hazardous area.

Use a cable (SD.Z10.0012.0*) to connect the station directly to a power supply and a PC.



The warnings and notes of caution contained in these operating instructions and in the manual issued by SICK AG (www.SICK.com) must be adhered to.

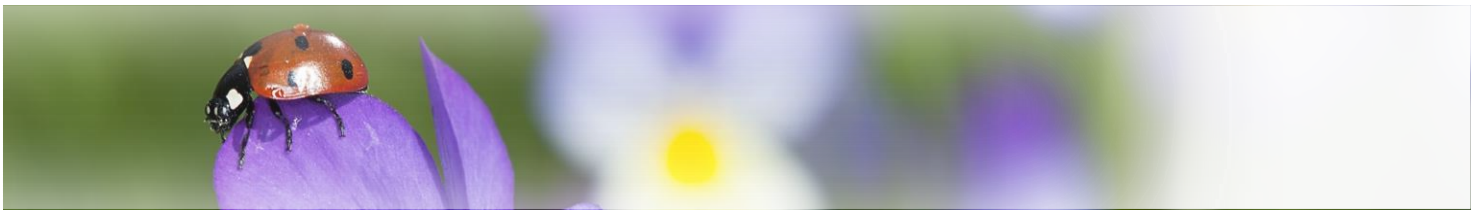

USB

Overview of the complete system design 2,
Bluetooth handheld scanner
zone 2/22 SD164BTII^{ex}

Design with non-ex-base charging
station outside the hazardous area

hazardous area



Bluetooth handheld scanner

non hazardous area

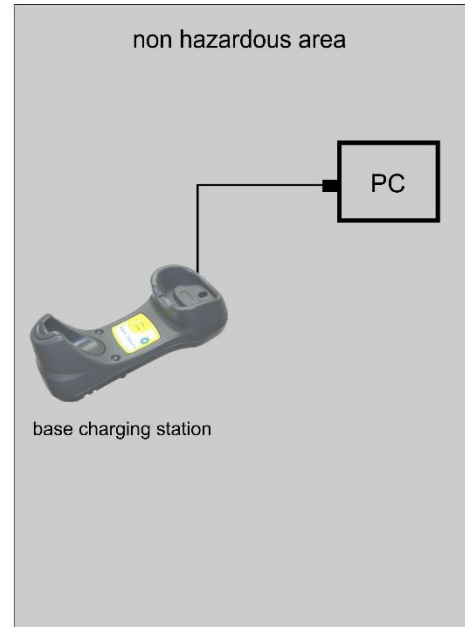

base charging station

Description:

The Bluetooth handheld scanner zone 2/22 SD164BTII^{ex} (SD.12F.0000.01) can also be used separately in the hazardous area.

The base non-ex base station /charging station (SD.Z10.0042.00 / SD.Z10.0036.00) is operated in the non-hazardous area.

Use a cable (SD.Z10.0013.0*) to connect the station directly to a power supply and a PC.



Die Warnhinweise dieser Betriebsanleitung und die des Handbuches der SICK AG (www.SICK.com) sind unbedingt zu beachten!

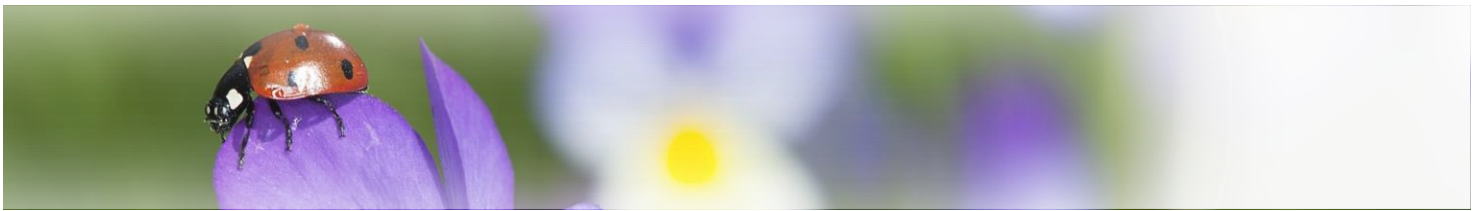





7 Product information - SD264BTII^{ex} Type SD.12G.0000.00

SD264BTII^{ex} 2D bluetooth scanner zone 2/22



7.1 Explosion Protection

-  II 3G Ex ic IIB T4
-  II 3G Ex ic IIB T4 Gc
-  II 3D Ex ic IIIC T135°C
-  II 3D Ex ic IIIC T135°C Dc

Certification

IBExU 14 ATEX B012 X

Manufacturer

Sigmann DELTA GmbH
Beim Braunstall 4
97980 Bad Mergentheim
Germany

7.2 Technical data

With Battery Typ SD.Z10.0039.** 3,6 V; less than 3.000 mAh

**Technical data
(Scanengine)**

- Light source: visible red light, 630nm
- Scan -rate: 60 scans per second
- Laser class: 1 (EN/IEC 60825-1:2014)
- Reader distance: 30mm to 400 mm

Bluetooth handheld scanner zone 2/22

Bluetooth™ V4.0, 2,402 ... 2,4830 GHz
Bis zu 100 m (functional distance, free space)

Dimensions

104 x 76,3 x 176 mm (length x width x height)

Ambient temperature

-20°C to +50°C

Storage temperature

-40°C to +70°C

Weight

280g, incl. battery

Protection category

IP65

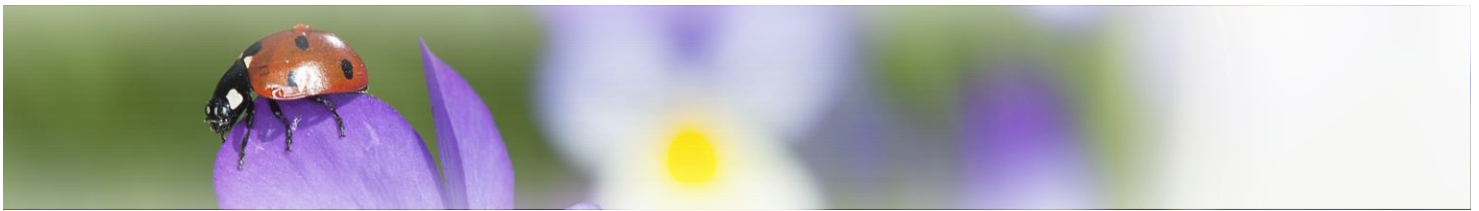

7.3 Technical data

Base station zone 2/22 SDx64BTII^{ex}Basis

Ambient temperature
Base charging station zone
2/22

-20°C to +50°C

Storage
Base charging station zone
2/22

-30°C to +70°C

Bluetooth
Base charging station zone
2/22

Bluetooth V 4.1 EDR, Class 1
2,402 ... 2,4830 GHz (ISM Band)

Bluetooth
Operational area

Up to 100 m (functional distance, free space)

Terminal assignment
(Base charging station zone
2/22)

USB

USB/D+ green
USB/D- white
GND black
+UB brown

RS 232

RS 232-TXD white
GND brown
+UB yellow

Operation
Base charging station zone
2/22

The base charging station zone 2/22 may be operated in hazardous areas. Its purpose is to receive data captured by the associated Bluetooth handheld scanner zone 2/22 (1D bar codes or 2D stacked codes) via Bluetooth.

Nominal values of the hazardous base charging station zone 2/22

- maximum input voltage U_i : 6,5 V
- maximum internal inductance L_i : negligible
- maximum internal capacitance C_i : 231 μ F with cable

Nominal values of the non-hazardous base charging station

Operating voltage $U =$ 5V
Power requirement $I =$ 85 mA in standby mode

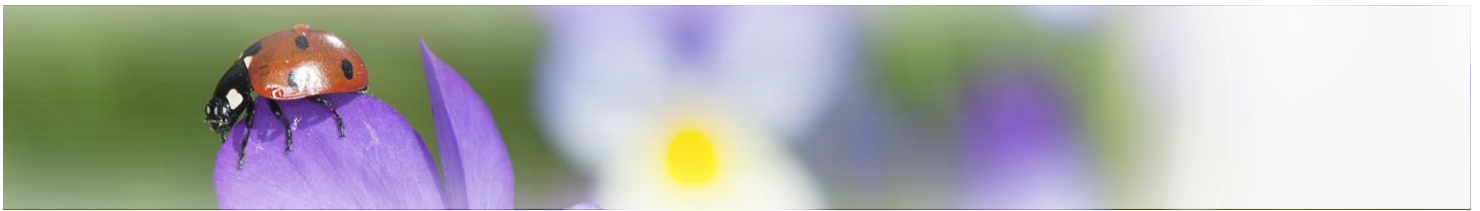

7.4 technical data

Supply zone 2/22

Supply cable SDUSBI^{ex} SD.121.00001.01

dimension 80 mm x 40 mm x 20 mm (length x width x height)

environmental temperature -20°C to +70°C

weight approx. 250 g

Non ex supply **voltage** U_N DC + 5 V ± 10 %

Non-ex data ±5 V / 68 mA

Ex data

- Max voltage U_m = 253 V AC
- Max voltage U_o = 6,38 V DC
- Max current I_o = 1,071 A
- Max power P_o = 6,83 W
- Max outer capacity C_o = < 265 µF (L_o = 0)
- Max outer inductance L_o = < 0,06 mH (C_o = 0)

Intrinsically safe circuit is grounded.

Pionning non-ex data Pin 3 Mini USB (grün): (D+) ± 5V / 68mA
Pin 2 Mini USB (weiß): (D-)

Pinning ex data coupling Pin 3 (green): (D+) U_i = 5,5V DC
coupling Pin 2 (white): (D-)

Connection cable See pin assignment

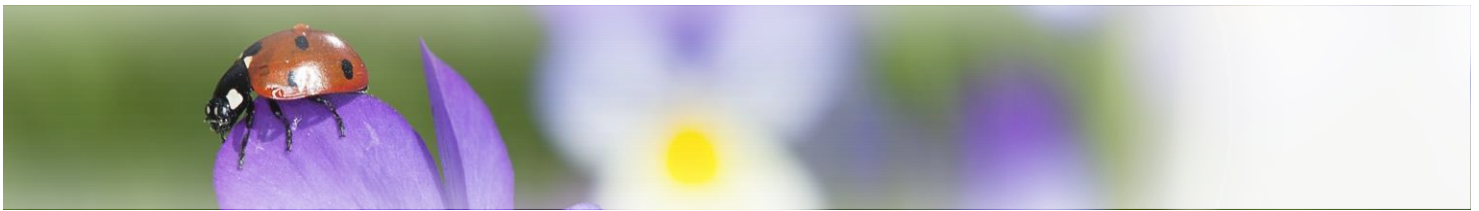

Supply cable SDRS232II^{ex} SD.121.00002.01

dimension	80 mm x 40 mm x 20 mm (length x width x height)		
environmental temperature	-20°C to +70°C		
weight	approx. 250 gr.		
Non ex supply	voltage	U_N	DC 10 ... 30 V
	max. current	I_i	approx. 100 - 200 mA (depending on the supply voltage)
Non-ex data	±12 V / 4mA bzw. +12/-7V / 4 mA		
Ex data	● Max voltage	U_m	= 253 V AC
	● Max voltage	U_o	= 6,38 V DC
	● Max current	I_o	= 1,071 A
	● Max power	P_o	= 6,83 W
	● Max outer capacity	C_o	= < 280 μF ($L_o = 0$)
	● Max outer inductance	L_o	= < 0,068 mH ($C_o = 0$)
	Intrinsically safe circuit is grounded.		
Pionning	RS232		RS422
non-ex data	wire1: TxD (white) ±12V / 4mA		wire3: T+ (yellow) +12/-7V / 4mA
	wire2: GND (brown)		wire4: T- (green)
Pinning ex data	coupling Pin 3 (white): (RxD)	$U_i = 5,5V$ DC	
	coupling Pin 2 (brown): (GND)		
Connection cable	See pin assignment		

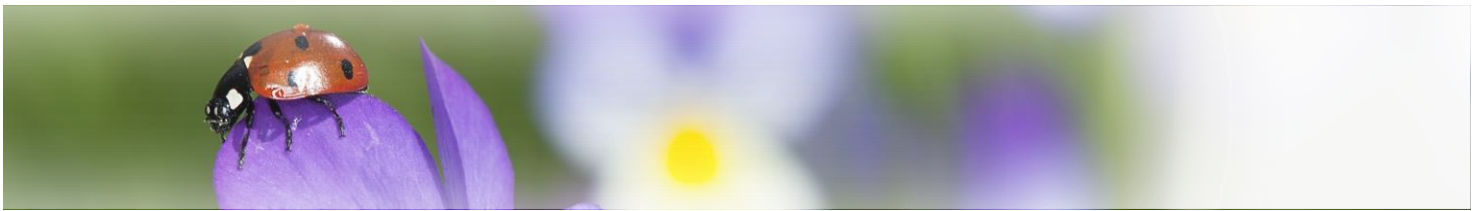

7.5 Type numbers - 2D Bluetooth scanner zone 2/22 SD264BTII^{ex}

SD 12G.0000.00

Standard 1D, Stacked PDF, 2D

Bluetooth handheld scanner zone 2/22 for use with battery SD.Z10.0039.00 and a base charging station zone 2/22 of your choice (see below)

Explosion-protected connection cable

RS232 SD.Z10.0010.0* / USB SD.Z10.0011.0*

or a non-explosion-protected connection

RS232 SD.Z10.0012.0* / USB SD.Z10.0013.0*

and a supply unit

SDUSBI^{ex} SD121.0001.01

SDRS232II^{ex} SD.121.0002.01

SD.12H.0000.01

Explosion-protected base charging station zone 2/22

SD.Z10.0042.00

Non-explosion-protected base charging station

SD.Z10.0036.00

Non-explosion-protected charging station without Bluetooth

7.6 Serial numbers

Serial key:

year of manufacture

serial number

2 numbers

4 numbers

Example:

240001

7.7 Application

The Bluetooth handheld scanner zone 2/22 is a handheld device.

Its purpose is the portable capture and direct transfer of data in hazardous areas. The device has been designed for use in hazardous areas zones 2 and 22.



The base station zone 2/22 may only be used in the hazardous area with one of the supplies listed under 7.4 .

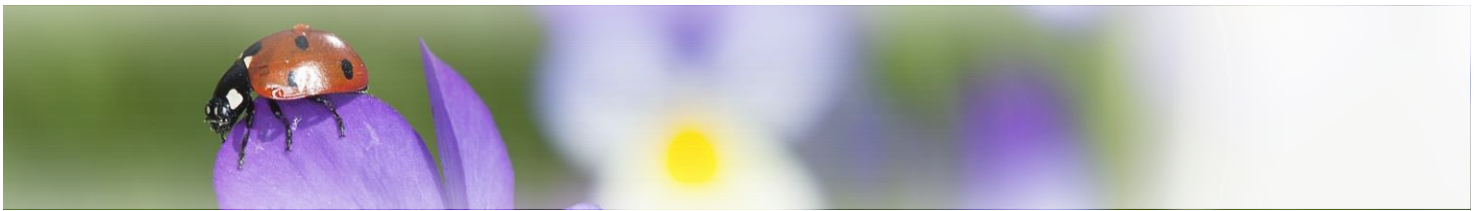

8 System design - 2D Bluetooth Scanner SD264BTII^{ex}

8.1 System design 1 with SDUSBI^{ex} in hazardous area

USB

Overview of the complete system design 1, Bluetooth handheld scanner zone 2/22 SD264BTII^{ex}

Design with base charging station zone 2/22 and supply cable SDUSBI^{ex} in hazardous area

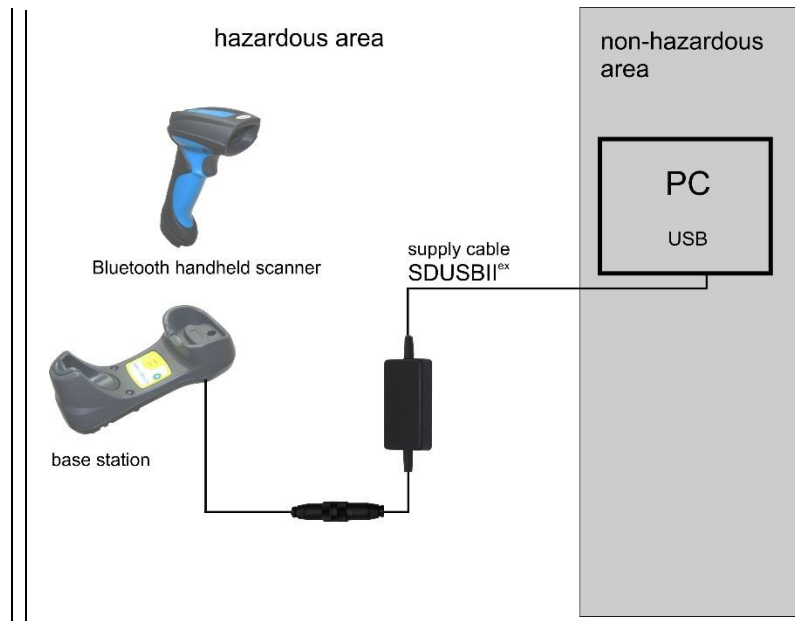

Description:

The Bluetooth handheld scanner zone 2/22 SD264BTII^{ex} (SD.12G.0000.00) is designed for use with battery (SD.Z10.0039.00) in hazardous areas. Normal operation requires a base charging station zone 2/22 (SD.12H.0000.00), a connection cable (SD.Z10.0011.0*) between the base charging station zone 2/22 and the supply cable SDUSBI^{ex} (SD.121.0001.01). For connection to the PC in the non-hazardous area, a mini USB plug is attached to the USB-supply cable so that the cable can be routed through a cable gland.

For connection to the USB port of the PC, a corresponding adapter is included.

Connecting cables of the supply cable:

Data / power cable USB 2.0

The Bluetooth handheld scanner zone 2/22, the base charging station zone 2/22 and the supply cable can be connected and operated in the hazardous area. The current rating of the connection cables must be checked before use.

The USB connection must be connected outside the hazardous area.



The warnings and notes of caution contained in these operating instructions and in the manual issued by SICK AG (www.SICK.com) must be adhered to.

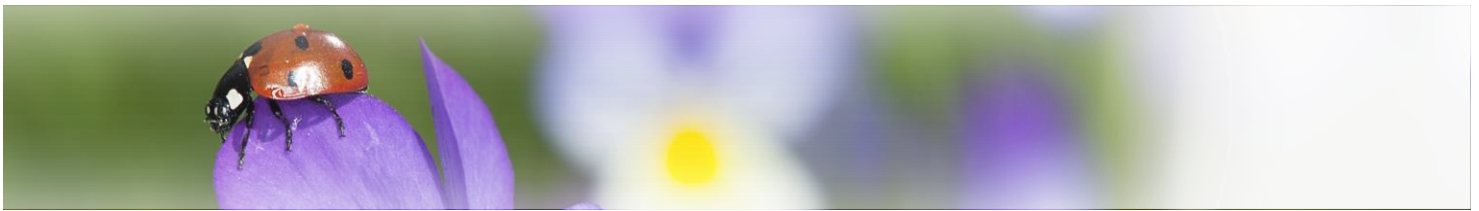

8.2 System design 1 with SDRS232II^{ex} in hazardous area

RS232

Overview of the complete system design 1, Bluetooth handheld scanner zone 2/22 SD264BTII^{ex}

Design with base charging station zone 2/22 and supply cable SDRS232II^{ex} in hazardous area

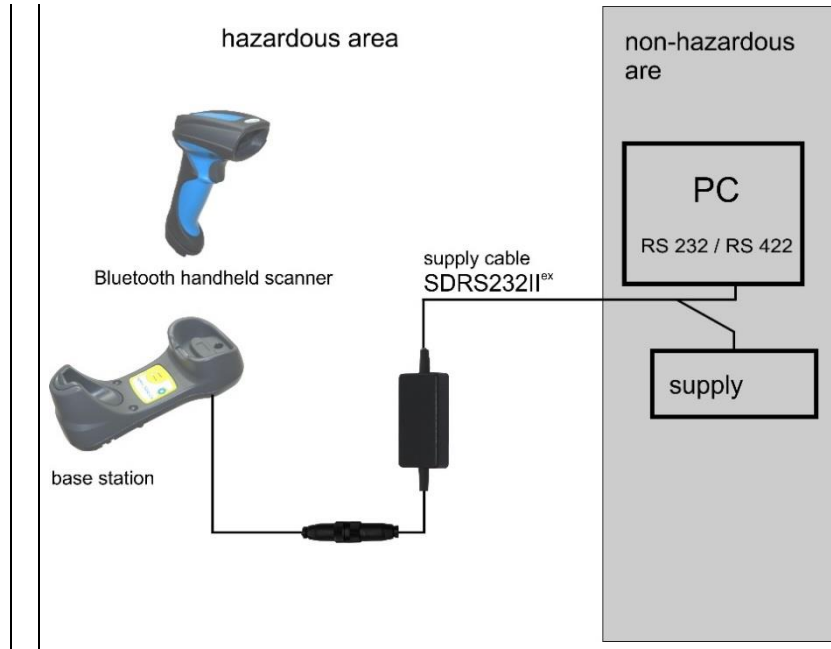

Description:

The Bluetooth handheld scanner zone 2/22 SD264BTII^{ex} (SD.12G.0000.00) is designed for use with battery (SD.Z10.0039.00) in hazardous areas. Normal operation requires a base charging station zone 2/22 (SD.12H.0000.00), a connection cable (SD.Z10.0010.0*) between the base charging station zone 2/22 and the supply cable SDRS232II^{ex} (SD.121.0002.01).

For connection to the RS232 port of the PC, a corresponding adapter is included.

Connection cables of the supply cable:

Data wires	RS232/RS422: 0,14 mm ² , 2-wire
supply wires	RS232/RS422: 0,14 mm ² , 2-wire

The Bluetooth handheld scanner zone 2/22, the base charging station zone 2/22 and the supply cable can be connected and operated in the hazardous area. The current rating of the connection cables must be checked before use.

The RS232 connection must be connected outside the hazardous area.



The warnings and notes of caution contained in these operating instructions and in the manual issued by SICK AG (www.SICK.com) must be adhered to.

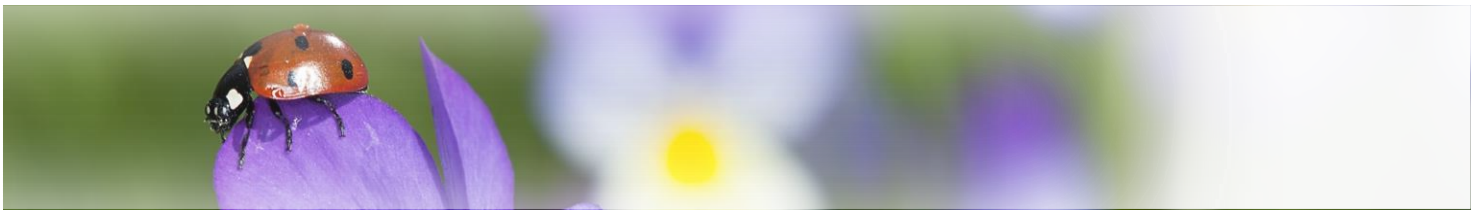

8.3 System design 2 with base station in non-hazardous area

RS232

Overview of the complete system design 2, Bluetooth handheld scanner zone 2/22 SD264BTII^{ex}

Design with base charging station outside the hazardous area

hazardous area



Bluetooth handheld scanner

non-hazardous area

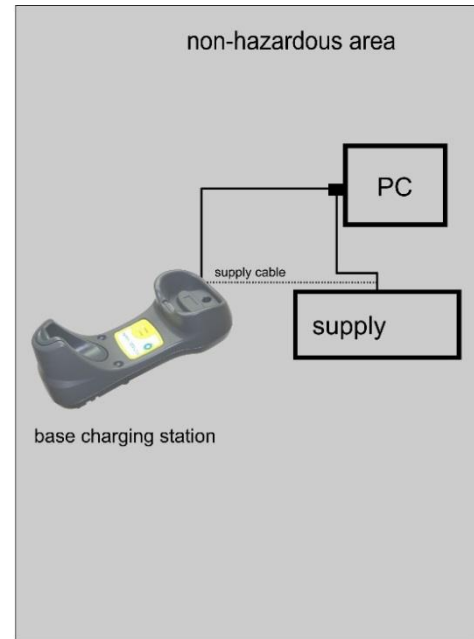

Description:

The Bluetooth handheld scanner SD264IIBT^{ex} (SD.12G.0000.00) can also be used separately in the hazardous area.

The base non-ex base station /charging station (SD.Z10.0042.00/SD.Z10.0036.00) is operated in the non-hazardous area.

Use a RS232 cable (SD.Z10.0012.0*) to connect the station directly to a power supply and a PC.



The warnings and notes of caution contained in these operating instructions and in the manual issued by SICK AG (www.SICK.com) must be adhered to.

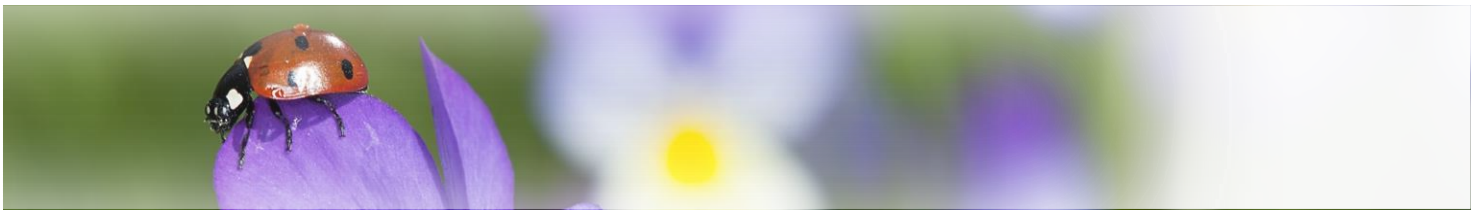

USB

Overview of the complete system design 2,
Bluetooth handheld scanner
zone 2/22 SD264BTII^{ex}

Design with non-ex-base charging
station outside the hazardous area

hazardous area



Bluetooth handheld scanner

non hazardous area

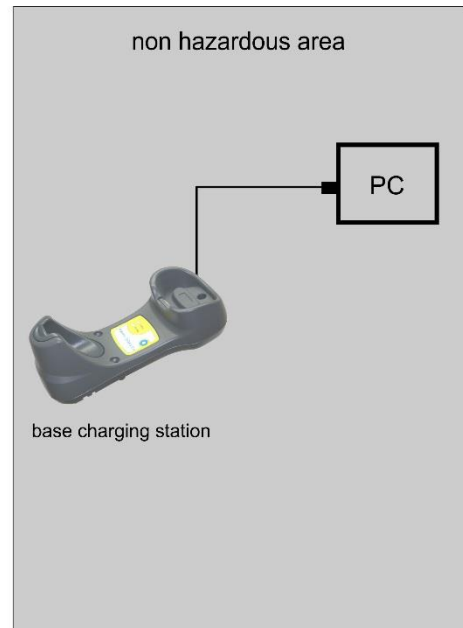

Description:

The Bluetooth handheld scanner zone 2/22 SD264BTII^{ex} (SD.12G.0000.00) can also be used separately in the hazardous area.

The base non-ex base station /charging station (SD.Z10.0036.00/SD.Z10.0042.00) is operated in the non-hazardous area.

Use an USB cable (SD.Z10.0013.0*) to connect the station directly to a power supply and a PC.





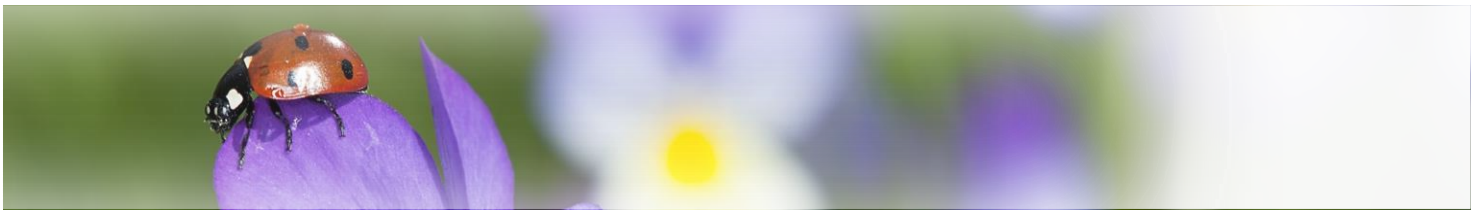

Die Warnhinweise dieser Betriebsanleitung und die des Handbuches der SICK AG (www.SICK.com) sind unbedingt zu beachten!





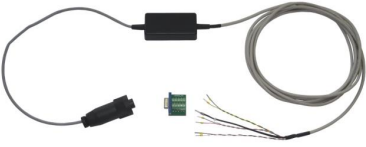

9 Cable range in system design

9.1 Cable range in system design 1

with SDRS232II^{ex}

RS232	Base station Zone 2/22	Connecting cable	Supply unit		System length	Host
						
	Base station Zone 2/22 SDx64BTII ^{ex} Basis	2m or 3,6m	Connection side with connector - coupling ca. 0,2m	SDRS232II ^{ex} 3m		max. 15m

with SDUSBI^{ex}

USB	Base station Zone 2/22	Connecting cable	Supply cable		System length	Host
						
	Base charging sta- tion Zone 2/22 SDx64BTII ^{ex} Basis	2m or 3,6m	Connection side with connector - coupling ca. 0,2m	SDUSBI ^{ex} (3m)		max. 5m





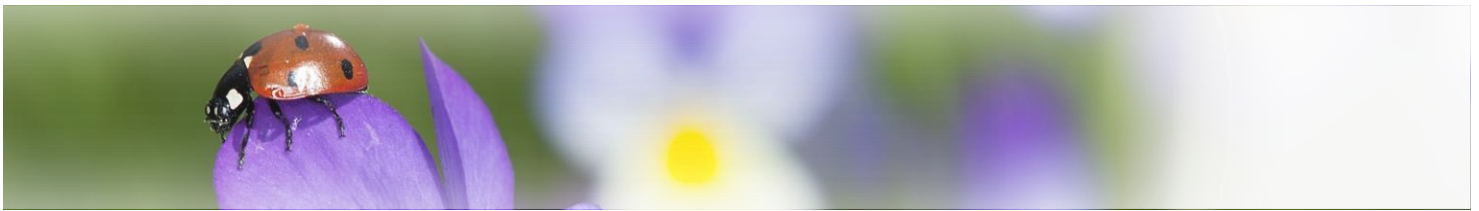

The spiral cables with a length of 3,6m should not be extended over a maximum of 3m. Otherwise the memory effect can not be guaranteed and the cable could be damaged.







9.2 Cable range in system design 2

RS232

RS232	Base charging station	Connecting cable	System length	Host
				
	Non-ex base charging station SDx64BTII-Basis	2m or 3,6m	max. 15m	

USB

USB	Base charging station	Connecting cable	System length	Host
				
	Non-ex base charging station SDx64BTII-Basis	2m or 3,6m	max. 5m	



The spiral cables with a length of 3,6m should not be extended over a maximum of 3m. Otherwise the memory effect can not be guaranteed and the cable could be damaged.

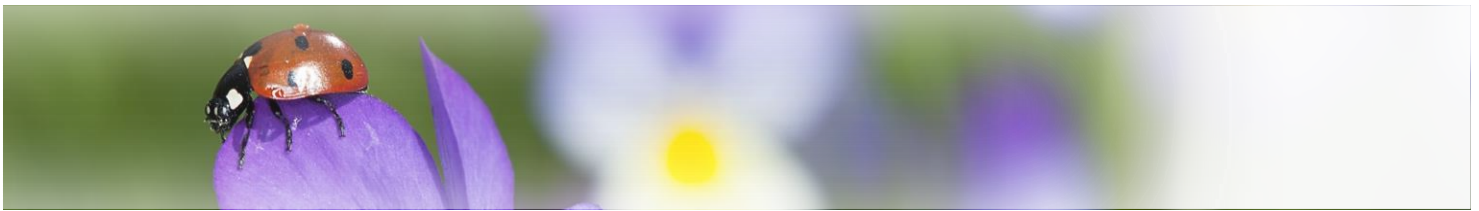

10 Dimensions Supply

10.1 Dimensions supply cable SDUSBIlex / SDRS232Ilex

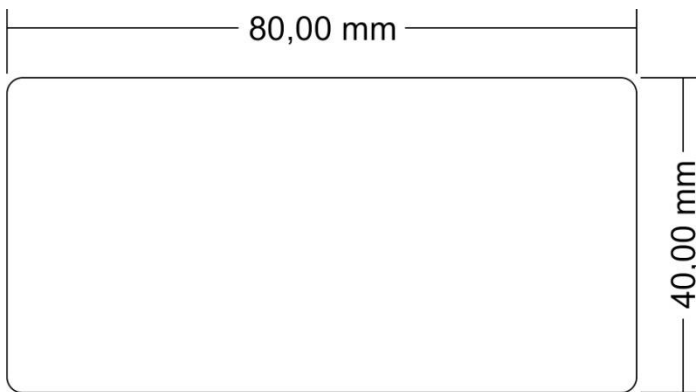

Outside dimensions of the electronic unit of the supply cables SDUSBIlex and SDRS232Ilex in top and side view.

80 mm x 40 mm x 20 mm (LxWxH)

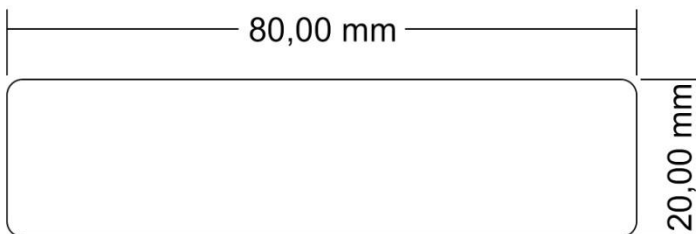

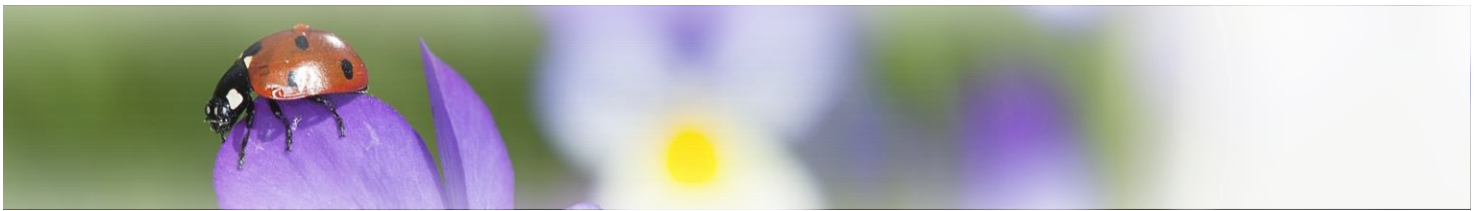

10.2 Cable lengths of the supply cable



USB

Scanner side 0,2 m

Host connection: 3 m

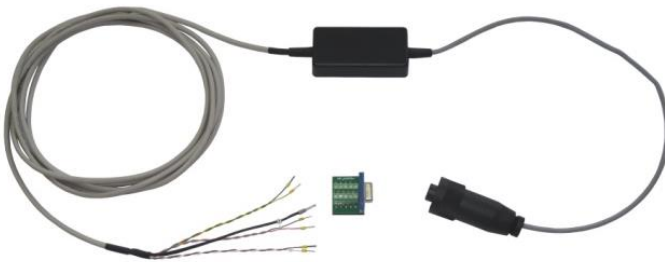









RS232

Scanner side 0,2 m

Host connection 3 m

11 Step-by-step guide on installation and operation





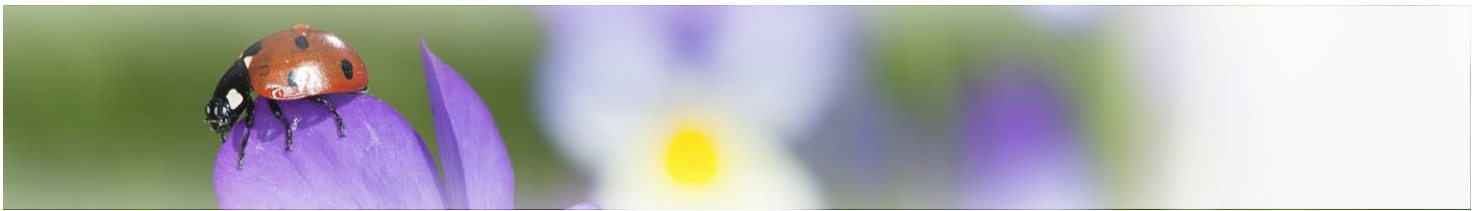



11.1 General connection of Bluetooth handheld scanner for system design 1 & 2

	<p>Do not replace battery in hazardous areas.</p> <p>Incorrect handling may result in the termination of the operating permit.</p>
	<p>The battery compartment is located at the bottom of the Bluetooth handheld scanner zone 2/22. Loosen the screw to remove the lid.</p>
	<p>Open battery compartment</p> <p> After the screw has been loosened, the removal of the lid requires a certain amount of force.</p>
	<p>SD.Z10.0039.00 battery is required to operate the Bluetooth handheld scanner zone 2/22.</p> <p> Only use this battery for the Bluetooth handheld scanner zone 2/22!</p> <p>Before placing the battery inside the bluetooth handheld scanner zone 2/22, remove its protective cap.</p>
	<p>Insert the battery into the battery compartment of the Bluetooth handheld scanner zone 2/22. The end of the removal strap must protrude from the opening.</p> <p> If the battery has been correctly inserted and connected to the contacts, this will be indicated by an acoustic and a visible signal.</p> <p>Close the compartment completely. Check that the screw has been tightened properly.</p>







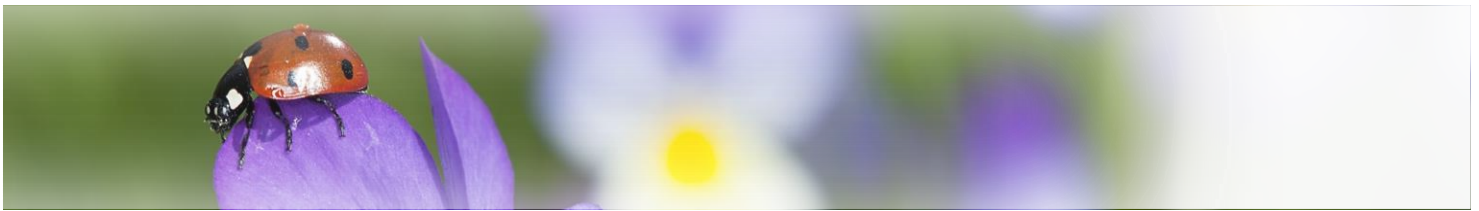

11.2 Using the base station SDx64BT^{ex}Basis (SD.12H.0000.00)

(Use the base charging station zone 2/22 in hazardous area - System design 1)

	<p>The device has been closed ex-factory.</p> <p>Incorrect handling may result in the termination of the operating permit.</p>
	<p>The cable connecting the base charging station zone 2/22 to the supply unit SD.Z10.001*.0* for RS232 or USB.</p>
	<p>Insert the cable in the opening at the bottom of the base charging station zone 2/22.</p> <p> If the cable has been inserted fully you can hear a "click". Check if the cable fits firmly.</p>
	<p>Insert the plug of the connection cable into the power supply's plug connector.</p> <p> Ensure that the connection is fully secured with the screw cap after the plug has been inserted.</p>
	<p>Place the handheld scanner zone 2/22 onto the charging station zone 2/22.</p> <p>Insert the lower part of the handle to ensure that the contacts for charging are connected properly.</p> <p> The LED at the head of the scanner will come on to indicate successful charging.</p>



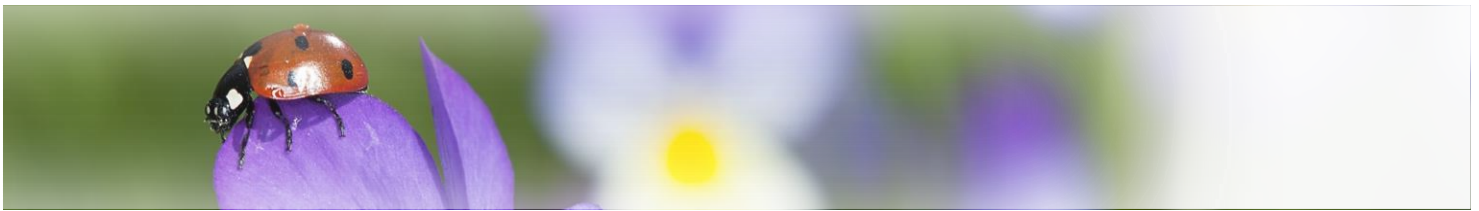

11.3 Using the non ex base / charging station (SD.Z10.0036.00/SD.Z10.0042.00) for SD164BTII^{ex} and SD264BTII^{ex} (Use base charging station in non-hazardous area - System design 2)

	<p>Charge the handheld scanner in non-hazardous area with a non-explosion-protected base charging station</p> <p>Use a non-hazardous area power supply SD.Z10.0016.00 for supply the base charging station.</p> <p>The cable is inserted in the corresponding opening at the bottom of the base charging station.</p> <p> This connection is closed ex-factory for a base charging station for hazardous areas.</p>
	<p>To connect the base charging station in a non-hazardous area, the connection cable for the power supply and the PC is inserted in the opening at the bottom of the base charging station. Use SD.Z10.0012.0* as a RS232 cable and SD.Z10.0013.0* as a USB cable]</p> <p> If the cable has been inserted fully you can hear a "click". Check that the cable fits firmly.</p>
	<p>Place the handheld scanner onto the non-ex-base unit /charging station.</p> <p>Insert the lower part of the handle to ensure that the contacts for charging are connected properly.</p> <p> The LED at the head of the scanner will come on to indicate successful charging.</p>

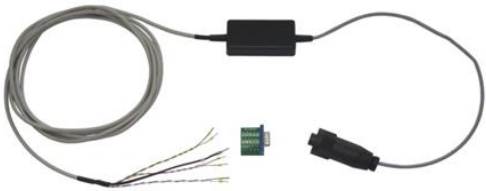

11.4 Pin assignment supply cable SDRS232II^{ex} (SD.121.0002.01) RS232 interface

Supply of the base charging station zone 2/22 according to system design 1 - with plug connection - plug/coupling

	<p>Caution! Do not open this enclosure!</p> <p> Before operating the device in hazardous area you have to ensure that the housing has been closed fully and is not damaged.</p> <p> Any changes to the pin assignment may only be carried out by trained staff.</p>
---	---

Connection base charging station zone 2/22 to the USB power supply with plug connection – plug/coupling

 Ex i connection	Base connection cable RS232 Type: SD.Z10.0010.0*		Supply cable Type: SD.121.0002.01	
	Pin assignment connection coupling		Connecting coupling	
	Pin	Definition	Pin	Wire
	2	GND (brown)	2	GND (brown)
3	TxD (white)	3	RS232 – TxD (white)	
1	+UB (yellow)	1	Supply (yellow)	

Supply and data transmission with RS232 interface to the higher-level system outside the hazardous area

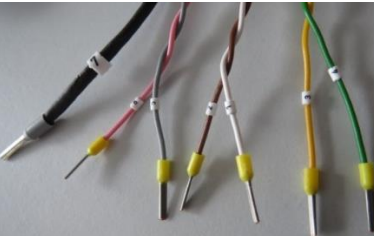
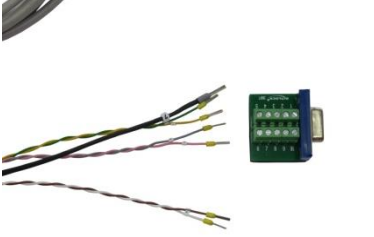
Ex e connection	Supply cable: Type SD.121.0002.01		
	Wire		
	wire	Definition	9 pin Sub-D RS232 pin
	1 (white)	TxD / RS232	2
	2 (brown)	GND / RS232	5
	3 (yellow)	TxD + / RS422	
	4 (green)	TxD - / RS422	
	5 (grey)	GND	
	6 (pink)	+UB (DC 10 V to DC 30 V)	
	7	Shielding	SHL

 The wires are connected with the enclosed Sub-D plug. Supply via wires 5 and 6. When connecting without Sub-D, the shield is set to GND. The wires of the RS422 connections must remain twisted to the contact.

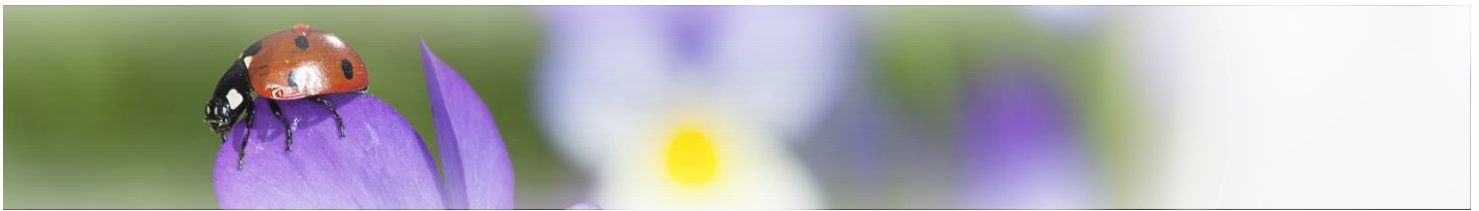

11.6 Pin assignment of the supply cable SDUSBII^{ex} (SD.121.0001.01) with USB interface

Supply of the base charging station zone 2/22 according to system design 1 - with plug connection - plug/coupling

	<p>Caution! Do not open this enclosure! Before operating the device in hazardous area you have to ensure that the housing has been closed fully and is not damaged.</p> <p>i Any changes to the pin assignment may only be carried out by trained staff</p>
--	---

Connection base charging station zone 2/22 to the USB supply cable with plug connection - plug/coupling

 Ex i Anschluss	Base connection cable USB Type: SD.Z10.0011.01		Supply cable Type: SD.121.0001.01	
	Pin assignment connection coupling		Connecting coupling	
	Pin	Definition	Pin	Definition
	1	+UB (brown/red)	1	+UB (red)
	2	D- (white)	2	D- (white)
	3	D+ (green)	3	D+ (green)
4	GND (black)	4	GND (black)	

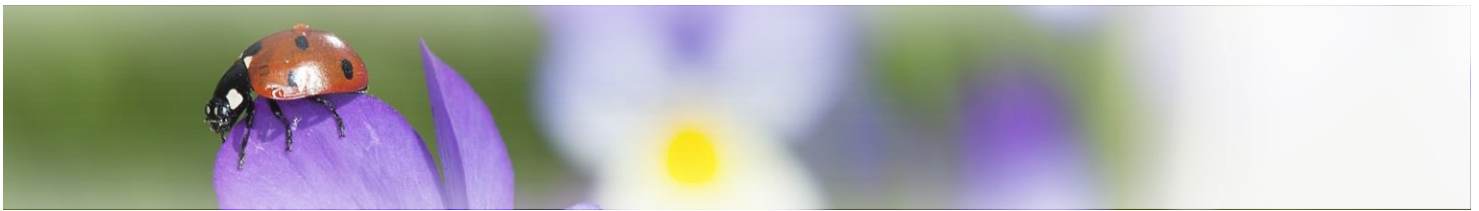

Supply and data transfer with USB interface to the higher-level system outside the hazardous area

<p>Ex e connection</p> 	Supply cable: SD.121.0001.01	
	wire	
	Definition	Mini USB Pin
	+ UB (DC 5 V)	1 (red)
	D -	2 (white)
	D +	3 (green)
	ID	4
GND	5 (black)	



There is an adapter from mini USB to USB A included. If the supply voltage of the USB interface is not able to supply a current > 500mA for corresponding barcode system assemblies, the enclosed Y-cable can be used. The operating instructions of the host system must be observed.

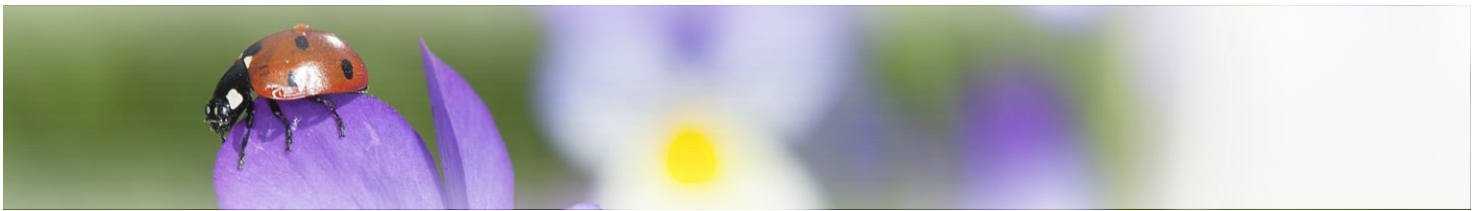

12 Attachment

12.1 Type examination certificate zone 2/22

IBExU Institut für Sicherheitstechnik GmbH
An-Institut der TU Bergakademie Freiberg

[1] **TYPE EXAMINATION CERTIFICATE - Translation** 

[2] for non-electrical products of equipment-groups I and II, equipment-categories M2 and 2 plus products of equipment-category 3

[3] Type examination certificate number **IBExU14ATEXB012 X** | Issue 6

[4] Product: **Hand scanner and accessories**

Hand scanner	Type
SD160II ^{ex}	SD.122.****.**
SD260II ^{ex}	SD.125.****.**
SD260II ^{ex} 3rd	SD.123.****.**
SD164II ^{ex}	SD.12D.****.**
SD264II ^{ex}	SD.12E.****.**
SD161BTII ^{ex}	SD.128.****.**
SD261BTII ^{ex}	SD.126.****.**
SD261BTII ^{ex} 3rd	SD.124.****.**
SD164BTII ^{ex}	SD.12F.****.**
SD264BTII ^{ex}	SD.12G.****.**
Base station	Type
SDx61BTII ^{ex} Basis	SD.129.****.**
SDx61BTII ^{ex} Basis 3rd	SD.127.****.**
SDx64BTII ^{ex} Basis	SD.12H.****.**
Supply module	Type
SDVM-SD160II ^{ex}	SD.321.****.**
Supply unit	Type
SDVE-SD160II ^{ex}	SD.251.****.**
Supply cable	Type
SDUSBII ^{ex}	SD.121.***1.**
SDRS232II ^{ex}	SD.121.***2.**

[5] Manufacturer: Sigmann Delta GmbH

[6] Address: Beim Braunstall 4
97980 Bad Mergentheim
GERMANY

[7] This product and any acceptable variation thereto is specified in the schedule to this certificate and the documents therein referred to.

[8] IBExU Institut für Sicherheitstechnik GmbH certifies that this product has been found to comply with the essential health and safety requirements relating to the design and construction of products intended for use in potentially explosive atmospheres given in Annex II to Directive 2014/34/EU of the European Parliament and of the Council, dated 26 February 2014.

The examination and test results are recorded in the confidential test report IB-22-3-0186.

[9] Compliance with the essential health and safety requirements has been assured by compliance with: EN IEC 60079-0:2018, EN IEC 60079-7:2015/A1:2018, EN 60079-11:2012, EN 60079-18:2015/A1:2017 and EN 60079-31:2014 except in respect of those requirements listed at item [18] of the schedule.

[10] If the sign "X" or "U" is placed after the certificate number, it indicates that the product is subject to the specific conditions of use specified in the schedule to this certificate.

Page 1/8
IBExU14ATEXB012 X | 6

FB106109 | 1

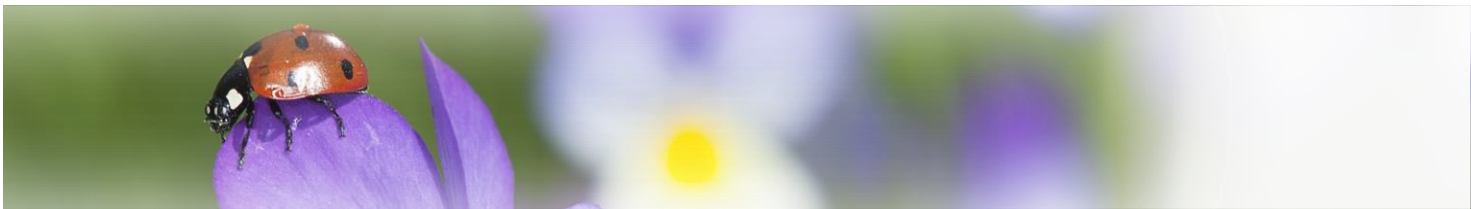



IBExU Institut für Sicherheitstechnik GmbH
An-Institut der TU Bergakademie Freiberg

[11] This type examination certificate relates only to the design of the specified equipment and not to specific items of equipment subsequently manufactured or supplied.



[12] The marking of the product shall include the following:

Hand scanner with cable:

SD160II^{ex}, SD260II^{ex}, SD164II^{ex}:



-  II 3G Ex ic IIC T4 Gc X
-  II 3D Ex ic IIIC T135 °C Dc X
-20 °C ≤ Ta ≤ +50 °C

SD260II^{ex} 3rd, SD264II^{ex}:

-  II 3G Ex ic IIB T4 Gc X
-  II 3D Ex ic IIIC T135 °C Dc X
-20 °C ≤ Ta ≤ +50 °C



Handscanner, battery operated:

SD161BTII^{ex}, SD261BTII^{ex}, SD261BTII^{ex} 3rd, SD164BTII^{ex}, SD264BTII^{ex}:

-  II 3G Ex ic IIB T4 Gc X
-  II 3D Ex ic IIIC T135 °C Dc X
-20 °C ≤ Ta ≤ +50 °C



Base station:

SDx61BTII^{ex} Basis, SDx61BTII^{ex} Basis 3rd, SDx64BTII^{ex} Basis:

-  II 3G Ex ic IIC T4 Gc X
-  II 3D Ex ic IIIC T135 °C Dc X
-20 °C ≤ Ta ≤ +50 °C

Supply module:

SDVM-SD160II^{ex}

-  II (3)G [Ex ic Gc] IIC X
-  II (3)D [Ex ic Dc] IIIC X

At type SD.321.****.1* with -20 °C ≤ Ta ≤ +60 °C
at type SD.321.****.2* (High Power) with -20 °C ≤ Ta ≤ +50 °C

Supply unit:

SDVE-SD160II^{ex}

-  II 3G Ex ec [ic] IIC T4 Gc X

(with SDVM-SD160II^{ex})

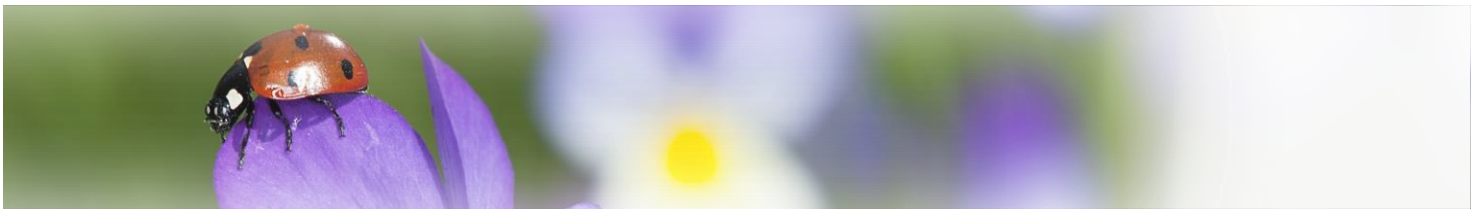

-  II 3D Ex tc [ic] IIIC T135 °C Dc X

at type SD.251.****.1* with -20 °C ≤ Ta ≤ +60 °C
at type SD.251.****.2* (High Power) with -20 °C ≤ Ta ≤ +50 °C



IBExU Institut für Sicherheitstechnik GmbH
An-Institut der TU Bergakademie Freiberg

Supply cable:

SDUSBII^{ex} and SDRS232II^{ex}  II 3G Ex mc [ic] IIC T4 Gc X or
 II 3G Ex mc [ic] IIB T4 Gc X
 II 3D Ex mc [ic] IIIC T135°C Dc X
-20 °C ≤ Ta ≤ +70 °C

IBExU Institut für Sicherheitstechnik GmbH
Fuchsmühlenweg 7
09599 Freiberg, GERMANY

Tel: + 49 (0) 37 31 / 38 05 0
Fax: + 49 (0) 37 31 / 38 05 10

By order



Dr.-Ing. P. Cimalla

IBExU
Institut für Sicherheitstechnik GmbH
Fuchsmühlenweg 7
09599 Freiberg/Sachsen
Telefon (03731) 3805-0
Telefax (03731) 38 05 10

- Stamp -

Certificates without signature and stamp are not valid. Certificates may only be duplicated completely and unchanged. In case of dispute, the German text shall prevail.

Freiberg, 2023-12-12

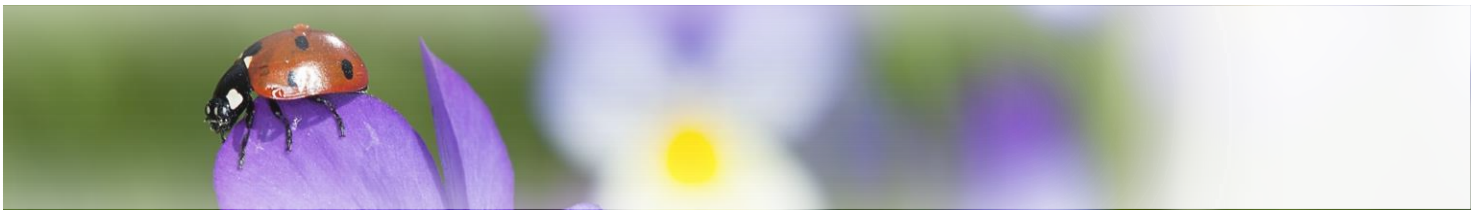

IBExU Institut für Sicherheitstechnik GmbH
An-Institut der TU Bergakademie Freiberg

[13] **Schedule**

[14] **Certificate number IBExU14ATEXB012 X | Issue 6**

[15] **Description of product**

The hand scanners are hand-held, intrinsically safe devices and are used to read barcodes in hazardous areas of categories 3G or 3D (Zone 2 or Zone 22).

The types SD160II^{ex}, SD260II^{ex} and SD260II^{ex} 3rd as well as SD164II^{ex} and SD264II^{ex} are provided with a cable. Power supply and data transmission are carried out via an exchangeable connecting cable.

The types SD161BTII^{ex}, SD261BTII^{ex} and SD261BTII^{ex} 3rd as well as SD164BTII^{ex} and SD264BTII^{ex} are battery operated. Power is supplied by an internal battery. Data can be transmitted wirelessly via Bluetooth connection to a base station of type SDx61BTII^{ex} Basis and SDx61BTII^{ex} Basis 3rd as well as SDx64BTII^{ex}Basis, which is also designed for operation in hazardous areas requiring equipment of categories 3G or 3D.

The integrated rechargeable battery is charged after the hand scanner has been placed on the charging charger of the base station. The battery can also be charged outside the hazardous area with a separate charging tray (type SD.Z10.0025.** or SD.Z10.0027.**, SD.Z10.0034.**, SD.Z10.0036.**) or using a base station (type SD.Z10.0026.** or SD.Z10.0028.**, SD.Z10.0035.**, SD.Z10.0037.**, SD.Z10.0041.**, SD.Z10.0042.**) with power supply unit (type SD.Z10.0016.**) outside the Ex area. Furthermore, the Bluetooth handheld scanners can also be charged with a Zone 1 Bluetooth base station (type SD.114.******, SD.117.******, SD.119.******, SD.11C.******, SD.11H.******) in Zone 2/22.

The wired hand-held scanner and the wired base station are connected to a SDVM-SD160II^{ex} power supply module via a connection cable. Two different variants of the supply module differ in output power (Low Power / High Power) and thus also in the permissible ambient temperature range.

The SDVM-SD160II^{ex} power supply module may be installed and operated in hazardous areas of categories 3G and 3D when installed in a separately certified housing. The combination of the power supply module with a housing designed for this purpose is referred to as the SDVE-SD160II^{ex} power supply unit.

As an alternative to the supply module, a device designated as a supply line can be used, which is also intended for operation in potentially explosive areas of categories 3G or 3D.

The supply cable type SDUSBI^{ex} and SDRS232II^{ex} are devices which, in addition to the data connection via USB or via the serial interfaces RS232 or RS422, provide the intrinsically safe power supply for wired hand-held scanners or for the base station with charging cradle. Only cables type SD.Z10.****** with a maximum length of 5 m (SDUSBI^{ex}) or 20 m (SDRS232II^{ex}) may be used for connection.

Technical Data:

	Hand scanner Type SD160II ^{ex} SD.122.******	Hand scanner Type SD260II ^{ex} SD.125.******	Hand scanner Type SD260II ^{ex} 3rd SD.123.******	Hand scanner Type SD164II ^{ex} SD.12D.******	Hand scanner Type SD264II ^{ex} SD.12E.******
maximum input voltage U _i	6.5 V	6.5 V	6.5 V	6.5 V	6.5 V
maximum input current I _i	-	-	-	1180 mA	1180 mA
maximum internal inductance L _i	negligible	negligible	negligible	negligible	negligible
maximum internal capacitance C _i	< 150 µF	< 203 µF	< 869 µF	< 141 µF	< 374 µF
Ambient temperature range	-20 °C ... +50 °C				
light source	visible red light, P _{opt} < 35 mW				

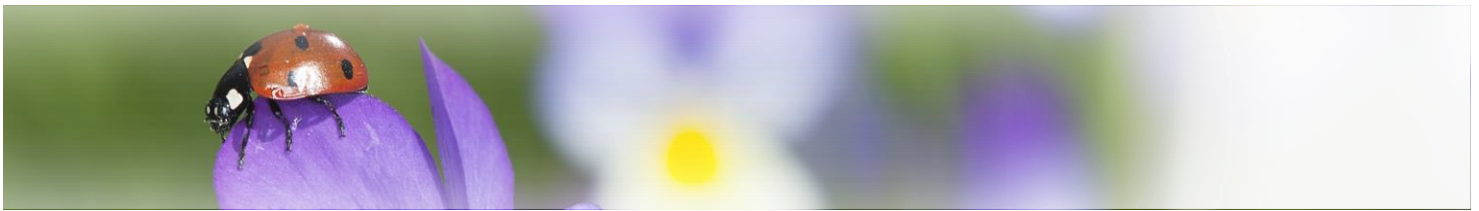

IBEXU Institut für Sicherheitstechnik GmbH
An-Institut der TU Bergakademie Freiberg

	BT Hand scanner Type SD161BTII ^{ex} SD.128.******	BT Hand scanner Type SD261BTII ^{ex} SD.126.******	BT Hand scanner Type SD261BTII ^{ex} 3 rd SD.124.******	BT Hand scanner Type SD164BTII ^{ex} SD.12F.******	BT Hand scanner Type SD264BTII ^{ex} SD.12G.******
maximum input voltage U _i	-	-	-	-	-
maximum internal inductance L _i	negligible	negligible	negligible	negligible	negligible
maximum internal capacitance C _i	401 µF	415 µF	1180 µF	278 µF	521 µF
Ambient temperature range	-20 °C ... +50 °C				
light source	visible red light, P _{opt} < 35 mW				
interface	Bluetooth V2.1/4.0 EDR; Bluetooth class 2/1, 2.402 – 2.4830 GHz; maximum range 30 m / 100 m serial interface RS-232/422; USB				
nominal current	330 mA (standby 80/130 mA; peak 500 mA)				
Battery	Type SD.Z10.0017.** (3.6 V; ≤ 1500 mAh) Type SD.Z10.0018.** (3.6 V; ≤ 2250 mAh) Type SD.Z10.0029.** (3.6 V; ≤ 3000 mAh) Type SD.Z10.0039.** (3.6 V; ≤ 2600 mAh)				

	Bluetooth Base station Type SDx61BTII ^{ex} Basis SD.129.******	Bluetooth Base station Type SDx61BTII ^{ex} Basis 3rd SD.127.******	Bluetooth Base station Type SDx64BTII ^{ex} Basis SD.12H.******
maximum input voltage U _i	6.5 V	6.5 V	6.5 V
maximum input current I _i	-	-	1180 mA
maximum internal inductance L _i	negligible	negligible	negligible
maximum internal capacitance C _i	144 µF	191 µF	231 µF
Ambient temperature range	-20 °C ... +50 °C		
interface	Bluetooth 4.0 EDR; Bluetooth class 2/1, 20 dBm (100 mW) 2.402 – 2.4830 GHz; maximum range 100 m		

Supply module
Type

SDVM-SD160II^{ex}
SD.321.****.1*

SD.321.****.2*

Ambient temperature range: T_a -20 °C ... +60 °C -20 °C ... +50 °C
maximum voltage U_m 253 V AC 253 V AC

Intrinsically safe data and supply circuit (terminals X5...X10):

maximum output voltage U _o	5.5 V DC	5.5 V DC
maximum output current I _o	440 mA	769 mA
maximum output power P _o	1.25 W	2.17 W
minimum internal resistance R _i	25 Ω	14.7 Ω
characteristic	trapezoid	trapezoid
maximum external capacitance C _o	< 997 µF (L _o = 0)	< 997 µF (L _o = 0)
maximum external inductance L _o	< 0.4 mH (C _o = 0)	< 0.11 mH (C _o = 0)

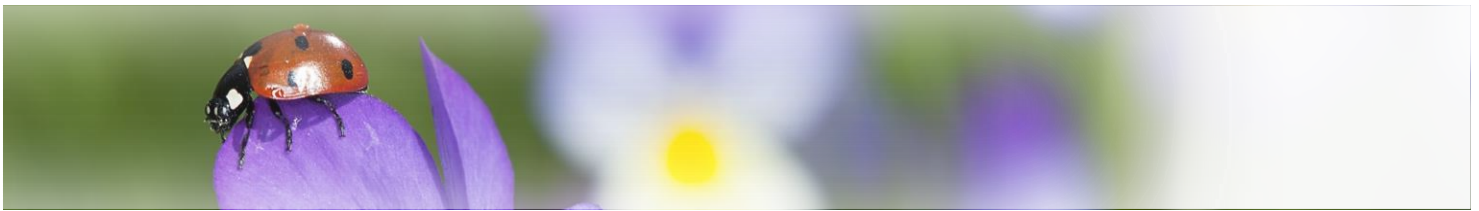

IBExU Institut für Sicherheitstechnik GmbH

An-Institut der TU Bergakademie Freiberg

maximum internal inductance	L_i	negligible	negligible
maximum internal capacitance	C_i	< 2.2 μ F	< 2.2 μ F

Non-intrinsically safe data and supply circuit (terminals X1...X4):

Supply circuit		12 V DC \pm 10 %	12 V DC \pm 10 %
		230 mA (****.1*)	360 mA (****.2*)
RS232-output	(TxD)	\pm 12 V, 4 mA	\pm 12 V, 4 mA
Equipotential bonding (shielding)	(PA)	terminal PA	terminal PA

Supply unit		SDVE-SD160II^{ex}	
Type		SD.251.****.1*	SD.251.****.2*

Ambient temperature range:	T_a	-20 °C ... +60 °C	-20 °C ... +50 °C
maximum voltage	U_m	253 V AC	253 V AC

Intrinsically safe data and supply circuit (terminals X5...X10):

maximum output voltage	U_o	5.5 V DC	5.5 V DC
maximum output current	I_o	440 mA	769 mA
maximum output power	P_o	1.25 W	2.17 W
minimum internal resistance	R_i	25 Ω	14,7 Ω
characteristic		trapezoid	trapezoid
maximum external capacitance	C_o	< 997 μ F ($L_o = 0$)	< 997 μ F ($L_o = 0$)
maximum external inductance	L_o	< 0,4 mH ($C_o = 0$)	< 0,11 mH ($C_o = 0$)
maximum internal inductance	L_i	negligible	negligible
maximum internal capacitance	C_i	< 2.2 μ F	< 2.2 μ F

Non-intrinsically safe data and supply circuit (terminals X1...X4):

Supply circuit		12 V DC \pm 10 %	12 V DC \pm 10 %
		230 mA (****.1*)	360 mA (****.2*)
RS232-output	(TxD)	\pm 12 V, 4 mA	\pm 12 V, 4 mA
Equipotential bonding (shielding)	(PA)	terminal PA	terminal PA

Supply cable USB		SDUSBII^{ex}	
Type		SD.121.****.1.**	

Ambient temperature range:	T_a	-20 °C ... +70 °C	
maximum voltage	U_m	253 V AC	

Intrinsically safe supply circuit (terminals X8...X10):

maximum output voltage	U_o	6.38 V DC	
maximum output current	I_o	1.071 A	
maximum output power	P_o	6.83 W	
characteristic		rectangular	

Intrinsically safe data circuit (terminals X6, X7):

maximum output voltage	U_o	4.82 V DC	
maximum output current / sum	I_o	39.2 mA	
maximum output current / D+	I_o	19.6 mA	
maximum output current / D-	I_o	19.6 mA	
maximum output power	P_o	47.1 mW	

intrinsically safe circuit (in total) (terminals X6 ... X10):

maximum output voltage	U_o	6.38 V DC	
maximum output current / sum	I_o	1.11 A	
maximum output power	P_o	6.88 W	
maximum internal capacitance	C_i	< 4.53 μ F	
maximum internal inductance	L_i	negligible	
maximum external capacitance	C_o	< 265 μ F ($L_o = 0$) (for IIC)	
		< 1500 μ F ($L_o = 0$) (for IIB)	
maximum external inductance	L_o	< 0,06 mH ($C_o = 0$) (for IIC and IIB)	

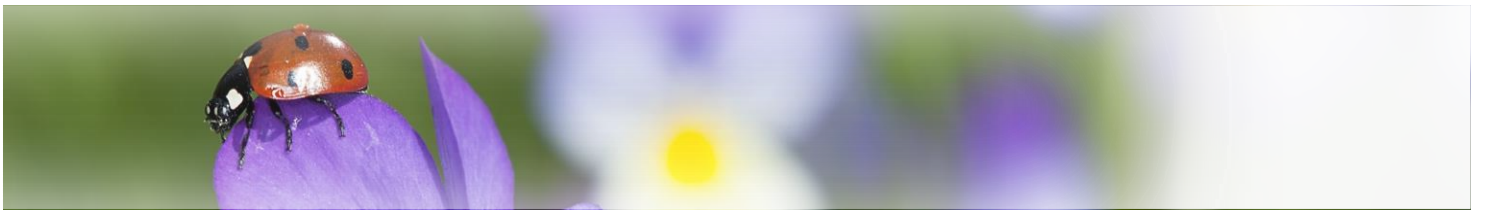

IBExU Institut für Sicherheitstechnik GmbH
An-Institut der TU Bergakademie Freiberg

Non-intrinsically safe data and supply circuit (terminals X1 ... X5):
Supply circuit 5 V DC (USB)
USB-circuit 5 V, D+: 68 mA (X1), D-: 68 mA (X2)
Equipotential bonding (shielding) terminal X3

Serial supply cable **SDRS232II^{ex}**
Type SD.121.***2.**

Ambient temperature range: T_a -20 °C ... +70 °C
maximum voltage U_m 253 V AC

Intrinsically safe supply circuit (terminals X8...X10):
maximum output voltage U_o 6.38 V DC
maximum output current I_o 1.071 A
maximum output power P_o 6.83 W
characteristic rectangular

intrinsically safe circuit (in total) (terminals X8 ... X11):
maximum output voltage U_o 6.38 V DC
maximum output current / sum I_o 1.071 A
maximum output power P_o 6.83 W
maximum internal capacitance C_i 126.2 nF
maximum internal inductance L_i negligible
maximum external capacitance C_o < 280 μ F ($L_o = 0$) (for IIC)
< 1500 μ F ($L_o = 0$) (for IIB)
maximum external inductance L_o < 0,068 mH ($C_o = 0$) (for IIC and IIB)

Non-intrinsically safe data and supply circuit (terminals X1 ... X7):
Supply circuit 10 ... 30 V DC (terminals X5, X7)
Data circuits RS232 TxD: ± 12 V, 4 mA (X1)
RS422: +12 V / -7 V T+: 4 mA (X3), T-: 4 mA (X4)
Equipotential bonding (shielding) terminal X6

Variations compared to issue 5 of this certificate:

Variation 1
The manufacturer's address has been changed.

Variation 2
Further types SD164II^{ex} and SD264II^{ex}, SD164BTII^{ex} and SD264BTII^{ex} as well as SDx64BTII^{ex}Basis have been added.

- [16] **Test report**
The test results are recorded in the confidential test report IB-22-3-0186 of 2023-10-19.
The test documents are part of the test report and they are listed there.

Summary of the test results
The equipment mentioned under [4] further fulfils the requirements for electrical equipment of type of protection intrinsic safety in addition with several types of protection for group II, category 3G and 3D.

- [17] **Specific conditions of use**
- The intrinsically safe parameter are mentioned in the instructions.
 - Replacing of battery is permitted outside the hazardous area.
- The following conditions are valid only for the supply cable types SDUSBI^{ex} and SDRS232II^{ex}:

IBExU Institut für Sicherheitstechnik GmbH
An-Institut der TU Bergakademie Freiberg

- Cleaning is permitted only with a damp cloth.
- The intrinsically safe parameter as well as the electrical parameter are mentioned in the instructions.
- The intrinsically safe circuit is grounded.
- The non-intrinsically safe USB connection as well as the free cable ends of the serial supply cable have to be connected outside the hazardous area.
- The device has to be removed from the hazardous area immediately after detecting damage.

[18] Essential health and safety requirements

In addition to the essential health and safety requirements (EHSRs) covered by the standards listed at item [9], the following are considered relevant to this product, and conformity is demonstrated in the test report:
None

[19] Drawings and Documents

The documents are listed in the test report.

IBExU Institut für Sicherheitstechnik GmbH
Fuchsmühlenweg 7
09599 Freiberg, GERMANY

By order



Dr.-Ing. P. Cimalla

Freiberg, 2023-12-12

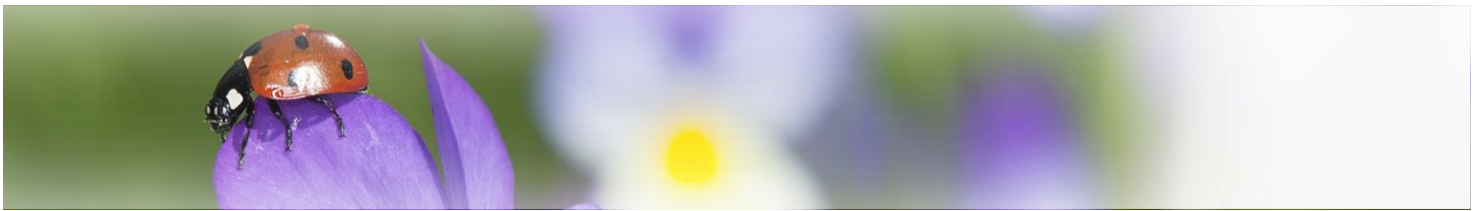

IECEX Certificate of Conformity

INTERNATIONAL ELECTROTECHNICAL COMMISSION IEC Certification System for Explosive Atmospheres

for rules and details of the IECEx Scheme visit www.iecex.com

Certificate No.: **IECEX IBE 19.0020X** Page 1 of 5 Certificate history:
 Status: **Current** Issue No: 3 Issue 2 (2023-11-09)
 Date of Issue: 2024-05-03 Issue 1 (2020-04-30)
 Issue 0 (2019-08-27)

Applicant: **Sigmann Delta GmbH**
 Beim Braunstall 4
 97980 Bad Mergentheim
 Germany

Equipment: **Hand scanners, base stations, supply modules, supply units and supply cables type SD. with EPL Gc and Dc**

Optional accessory:

Type of Protection: **Intrinsic safety "i", increased safety "e", encapsulation "m" or protection by enclosure "t"**

Marking:

Hand scanner with cable		Hand scanner, battery operated	Base station
SD160II ^{ex} , SD260II ^{ex} , SD164II ^{ex}	SD260II ^{ex} 3rd, SD264II ^{ex}	SD161BTII ^{ex} , SD261BTII ^{ex} , SD261BTII ^{ex} 3rd, SD164BTII ^{ex} , SD264BTII ^{ex}	SDx61BTII ^{ex} Basis, SDx61BTII ^{ex} Basis 3rd, SDx64BTII ^{ex} Basis
Ex ic IIC T4 Gc Ex ic IIIC T135 °C Dc -20 °C ≤ T _a ≤ +50 °C	Ex ic IIB T4 Gc Ex ic IIIC T135 °C Dc -20 °C ≤ T _a ≤ +50 °C	Ex ic IIB T4 Gc Ex ic IIIC T135 °C Dc -20 °C ≤ T _a ≤ +50 °C	Ex ic IIC T4 Gc Ex ic IIIC T135 °C Dc -20 °C ≤ T _a ≤ +50 °C
Supply module		Supply unit	Supply cable
SDVM-SD160II ^{ex}		SDVE-SD160II ^{ex}	SDUSBII ^{ex} and SDRS232II ^{ex}
[Ex ic Gc] IIC [Ex ic Dc] IIIC at type SD.321.****.1*: -20 °C ≤ T _a ≤ +60 °C at type SD.321.****.2* (High power): -20 °C ≤ T _a ≤ +50 °C		Ex ec [ic] IIC T4 Gc (with SDVM-SD160II ^{ex}) Ex tc [ic] IIIC T135 °C Dc at type SD.251.****.1*: -20 °C ≤ T _a ≤ +60 °C at type SD.251.****.2* (High power): -20 °C ≤ T _a ≤ +50 °C	Ex mc [ic] IIC T4 Gc or Ex mc [ic] IIB T4 Gc Ex mc [ic] IIIC T135 °C Dc -20 °C ≤ T _a ≤ +70 °C

Approved for issue on behalf of the IECEx
 Certification Body:

Dr.-Ing. Peter Cimalla

Position:

Deputy Head of department Certification Body

Signature:
 (for printed version)

Date:
 (for printed version)

1. This certificate and schedule may only be reproduced in full.
2. This certificate is not transferable and remains the property of the issuing body.
3. The Status and authenticity of this certificate may be verified by visiting www.iecex.com or use of this QR Code.



Certificate issued by:

IBEXU Institut für Sicherheitstechnik GmbH
 Fuchsmühlenweg 7
 09599 Freiberg
 Germany



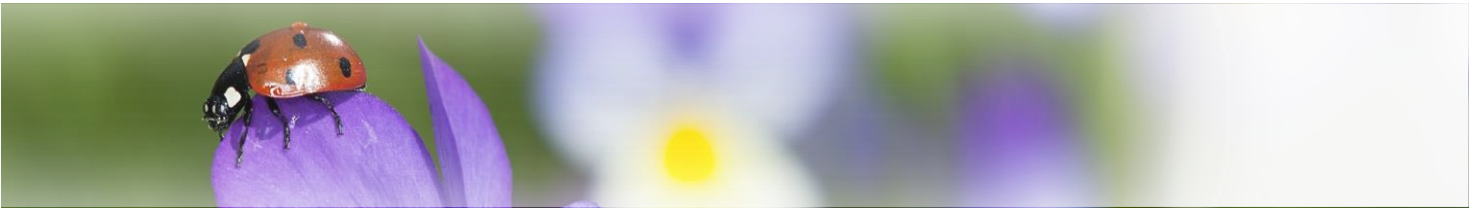

IECEX Certificate of Conformity

Certificate No.: **IECEX IBE 19.0020X** Page 2 of 5
Date of issue: 2024-05-03 Issue No: 3

Manufacturer: **Sigmann Delta GmbH**
Beim Braunstall 4
97980 Bad Mergentheim
Germany

Manufacturing locations:

This certificate is issued as verification that a sample(s), representative of production, was assessed and tested and found to comply with the IEC Standard list below and that the manufacturer's quality system, relating to the Ex products covered by this certificate, was assessed and found to comply with the IECEX Quality system requirements. This certificate is granted subject to the conditions as set out in IECEX Scheme Rules, IECEX 02 and Operational Documents as amended

STANDARDS :

The equipment and any acceptable variations to it specified in the schedule of this certificate and the identified documents, was found to comply with the following standards

- IEC 60079-0:2017 Explosive atmospheres - Part 0: Equipment - General requirements
Edition:7.0
- IEC 60079-11:2011 Explosive atmospheres - Part 11: Equipment protection by intrinsic safety "i"
Edition:6.0
- IEC 60079-18:2017 Explosive atmospheres - Part 18: Protection by encapsulation "m"
Edition:4.1
- IEC 60079-31:2013 Explosive atmospheres - Part 31: Equipment dust ignition protection by enclosure "t"
Edition:2
- IEC 60079-7:2017 Explosive atmospheres - Part 7: Equipment protection by increased safety "e"
Edition:5.1

This Certificate **does not** indicate compliance with safety and performance requirements other than those expressly included in the Standards listed above.

TEST & ASSESSMENT REPORTS:

A sample(s) of the equipment listed has successfully met the examination and test requirements as recorded in:

Test Reports:

DE/IBE/ExTR19.0017/00 DE/IBE/ExTR19.0017/01 DE/IBE/ExTR19.0017/02
DE/IBE/ExTR19.0017/03 DE/IBE/ExTR19.0017/04 DE/IBE/ExTR19.0017/05

Quality Assessment Report:

DE/IBE/QAR15.0005/04

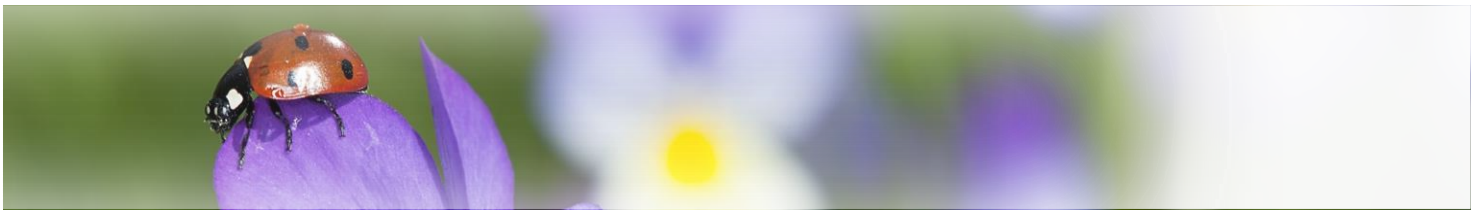

IECEX Certificate of Conformity

Certificate No.: **IECEX IBE 19.0020X**

Page 3 of 5

Date of issue: 2024-05-03

Issue No: 3

EQUIPMENT:

Equipment and systems covered by this Certificate are as follows:

The equipment comprises the following types:

Hand scanner	Type
SD160II ^{EX}	SD.122.****.**
SD260II ^{EX}	SD.125.****.**
SD260II ^{EX} 3rd	SD.123.****.**
SD164II ^{EX}	SD.12D.****.**
SD264II ^{EX}	SD.12E.****.**
SD161BTII ^{EX}	SD.128.****.**
SD261BTII ^{EX}	SD.126.****.**
SD261BTII ^{EX} 3rd	SD.124.****.**
SD164BTII ^{EX}	SD.12F.****.**
SD264BTII ^{EX}	SD.12G.****.**
Base station	Type
SDx61BTII ^{EX} Basis	SD.129.****.**
SDx61BTII ^{EX} Basis 3rd	SD.127.****.**
SDx64BTII ^{EX} Basis	SD.12H.****.**
Supply module	Type
SDVM-SD160II ^{EX}	SD.321.****.**
Supply unit	Type
SDVE-SD160II ^{EX}	SD.251.****.**
Supply cable	Type
SDUSBII ^{EX}	SD.121.***1.**
SDRS232II ^{EX}	SD.121.***2.**

SPECIFIC CONDITIONS OF USE: YES as shown below:

The intrinsically safe parameter are mentioned in the instructions.

Replacing of battery is only permitted outside the hazardous area.

The following conditions are specific for the supply cables SDUSBII^{EX} and SDRS232II^{EX}:

Cleaning is permitted only with a damp cloth.

The intrinsically safe parameter as well as the electrical parameters are mentioned in the instructions.

The intrinsically safe circuit is grounded.

The non-intrinsically safe USB connection as well as the free cable ends of the serial supply cable have to be connected outside of the hazardous area.

The device has to be removed from the hazardous area immediately when damaged.

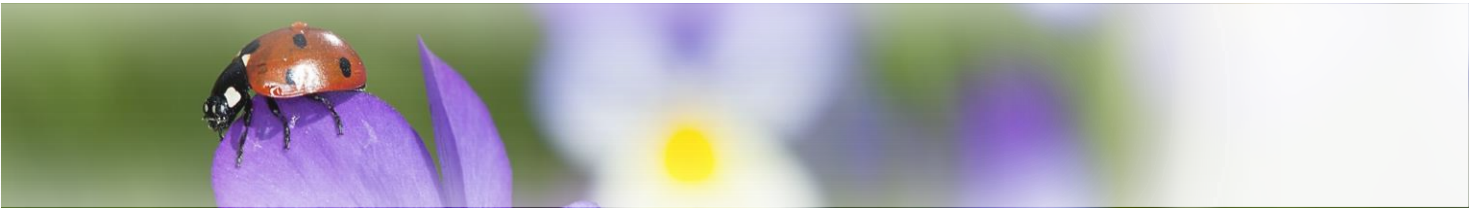

IECEX Certificate of Conformity

Certificate No.: **IECEX IBE 19.0020X**

Page 4 of 5

Date of issue: 2024-05-03

Issue No: 3

Equipment (continued):

The hand scanners are hand-held, intrinsically safe devices and are used to read barcodes in hazardous areas requiring equipment of EPL Gc or Dc (Zone 2 or Zone 22).

The types SD160II^{EX}, SD260II^{EX} and SD260II^{EX} 3rd as well as SD164II^{EX} and SD264II^{EX} are provided with a cable. Power supply and data transmission are carried out via an exchangeable connecting cable.

The types SD161BTII^{EX}, SD261BTII^{EX} and SD261BTII^{EX} 3rd as well as SD164BTII^{EX} and SD264BTII^{EX} are battery operated. Power is supplied by an internal battery. Data can be transmitted wirelessly via Bluetooth connection to a base station of type SDx61BTII^{EX}Basis and SDx61BTII^{EX}Basis 3rd as well as SDx64BTII^{EX}Basis, which is also designed for operation in hazardous areas requiring equipment of EPL Gc or Dc.

The integrated rechargeable battery is charged after the hand scanner has been placed on the charging charger of the base station. The battery can also be charged outside the hazardous area with a separate charging tray (type SD.Z10.0025.** or SD.Z10.0027**, SD.Z10.0034.**, SD.Z10.0036.**) or using a base station (type SD.Z10.0026.** or SD.Z10.0028**, SD.Z10.0035**, SD.Z10.0037**, SD.Z10.0041**, SD.Z10.0042**) with power supply unit (type SD.Z10.0016**) outside the Ex area. Furthermore, the Bluetooth handheld scanners can also be charged with a Zone 1 Bluetooth base station (type SD.114.******, SD.117.******, SD.119.******, SD.11C.******, SD.11H.******) in Zone 2/22.

The wired hand-held scanner and the wired base station are connected to a SDVM-SD160II^{EX} power supply module via a connection cable. Two different variants of the supply module differ in output power (Low Power / High Power) and thus also in the permissible ambient temperature range.

The SDVM-SD160II^{EX} power supply module may be installed and operated in hazardous areas requiring equipment of EPL Gc or Dc when installed in a separately certified housing. The combination of the power supply module with a housing designed for this purpose is referred to as the SDVE-SD160II^{EX} power supply unit.

As an alternative to the supply module, a device designated as a supply line can be used, which is also intended for operation in potentially explosive areas requiring equipment of EPL Gc or Dc.

The supply cable type SDUSBII^{EX} and SDRS232II^{EX} are devices which, in addition to the data connection via USB or via the serial interfaces RS232 or RS422, provide the intrinsically safe power supply for wired hand-held scanners or for the base station with charging cradle. Only cables type SD.Z10.****** with a maximum length of 5 m (SDUSBII^{EX}) or 20 m (SDRS232II^{EX}) may be used for connection.

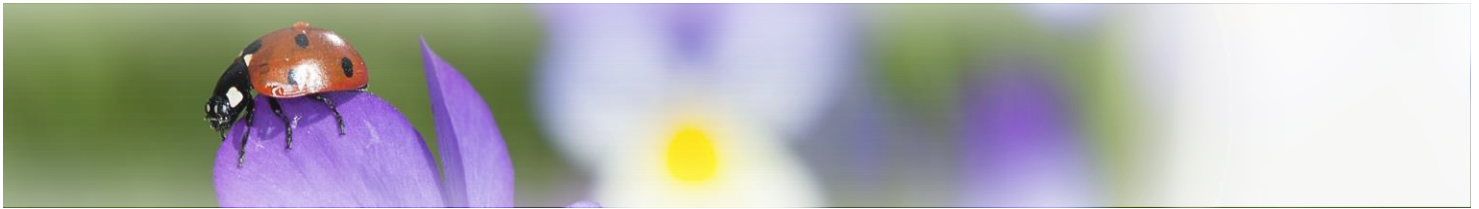

IECEx Certificate of Conformity

Certificate No.: **IECEx IBE 19.0020X**

Page 5 of 5

Date of issue: 2024-05-03

Issue No: 3

DETAILS OF CERTIFICATE CHANGES (for issues 1 and above)

Correction of intrinsically safe values and placeholder in the type designation.

Annex:

[Annex_IBE19.0020X_03.pdf](#)

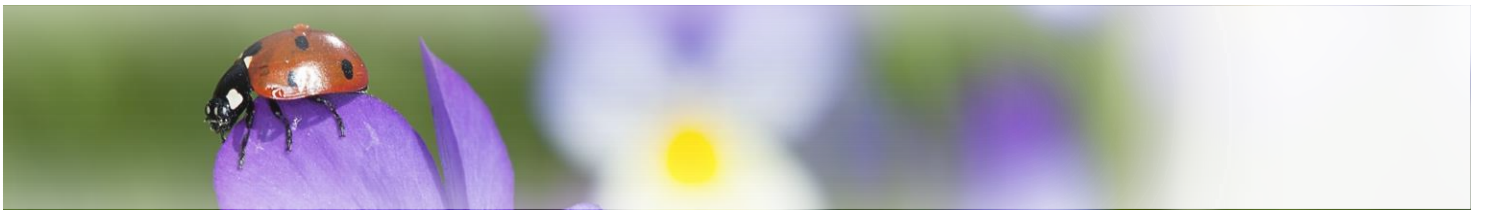



IECEX Certificate of Conformity - Annex



Certificate No: IECEX IBE 19.0020X

Issue No: 3

Date of Issue: 2024-05-03

Page 2 of 4

	Bluetooth Base station Type SDx61BTII ^{ex} Basis SD.129.****.**	Bluetooth Base station Type SDx61BTII ^{ex} Basis 3rd SD.127.****.**	Bluetooth Base station Type SDx64BTII ^{ex} Basis SD.12H.****.**
maximum input voltage U _i	6.5 V	6.5 V	6.5 V
maximum input current I _i	-	-	1180 mA
maximum internal inductance L _i	negligible	negligible	negligible
maximum internal capacitance C _i	144 µF	191 µF	231 µF
Ambient temperature range	-20 °C ... +50 °C		
interface	Bluetooth 4.0 EDR; Bluetooth class 2/1, 20 dBm (100 mW) 2.402 – 2.4830 GHz; maximum range 100 m		

Supply module

Type **SDVM-SD160II^{ex}**
SD.321.****.1* SD.321.****.2*

Ambient temperature range: T_a -20 °C ... +60 °C -20 °C ... +50 °C

maximum voltage U_m 253 V AC 253 V AC

Intrinsically safe data and supply circuit (terminals X5...X10):

maximum output voltage U _o	5.5 V DC	5.5 V DC
maximum output current I _o	440 mA	769 mA
maximum output power P _o	1.25 W	2.17 W
minimum internal resistance R _i	25 Ω	14.7 Ω
characteristic	trapezoid	trapezoid
maximum external capacitance C _o	< 997 µF (L _o = 0)	< 997 µF (L _o = 0)
maximum external inductance L _o	< 0.4 mH (C _o = 0)	< 0.11 mH (C _o = 0)
maximum internal inductance L _i	negligible	negligible
maximum internal capacitance C _i	< 2.2 µF	< 2.2 µF

Non-intrinsically safe data and supply circuit (terminals X1...X4):

Supply circuit 12 V DC ±10 % 12 V DC ±10 %
230 mA (****.1*) 360 mA (****.2*)

RS232-output (TxD) ±12 V, 4 mA ±12 V, 4 mA

Equipotential bonding (PA) terminal PA terminal PA
(shielding)

Supply unit

Type **SDVE-SD160II^{ex}**
SD.251.****.1* SD.251.****.2*

Ambient temperature range: T_a -20 °C ... +60 °C -20 °C ... +50 °C

maximum voltage U_m 253 V AC 253 V AC

Intrinsically safe data and supply circuit (terminals X5...X10):

maximum output voltage U _o	5.5 V DC	5.5 V DC
maximum output current I _o	440 mA	769 mA
maximum output power P _o	1.25 W	2.17 W

F8107009_L_170526 | Vorlage: 00V0002v170_170117 | öffentlich

SD164BTIIex_SD264BTIIex_BA_en_003.docx

55

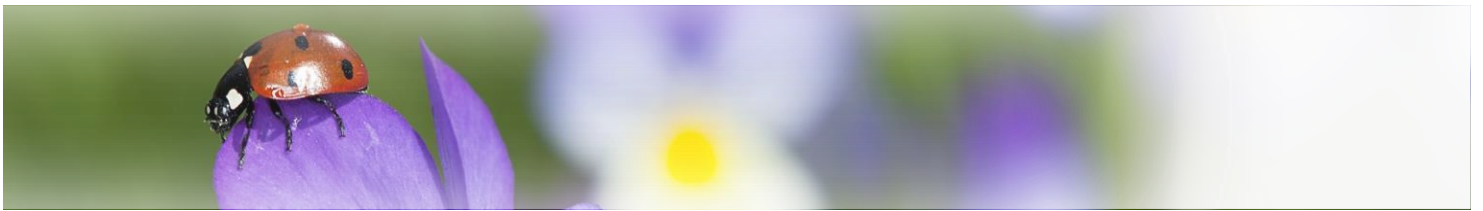

IECEX Certificate of Conformity - Annex



Certificate No: IECEx IBE 19.0020X Issue No: 3
Date of Issue: 2024-05-03 Page 4 of 4

Serial supply cable **SDRS232II^{ex}**
Type SD.121.**2.**

Ambient temperature range: T_a -20 °C ... +70 °C
maximum voltage U_m 253 V AC

Intrinsically safe supply circuit (terminals X8...X10):
maximum output voltage U_o 6.38 V DC
maximum output current I_o 1.071 A
maximum output power P_o 6.83 W
characteristic rectangular

intrinsically safe circuit (in total) (terminals X8 ... X11):
maximum output voltage U_o 6.38 V DC
maximum output current / sum I_o 1.071 A
maximum output power P_o 6.83 W
maximum internal capacitance C_i 126.2 nF
maximum internal inductance L_i negligible
maximum external capacitance C_o < 280 μ F ($L_o = 0$) (for IIC)
< 1500 μ F ($L_o = 0$) (for IIB)
maximum external inductance L_o < 0,068 mH ($C_o = 0$) (for IIC and IIB)

Non-intrinsically safe data and supply circuit (terminals X1 ... X7):
Supply circuit 10 ... 30 V DC (terminals X5, X7)
Data circuits RS232 TxD: ± 12 V, 4 mA (X1)
RS422: +12 V / -7 V T+: 4 mA (X3), T-: 4 mA (X4)
Equipotential bonding (shielding) terminal X6

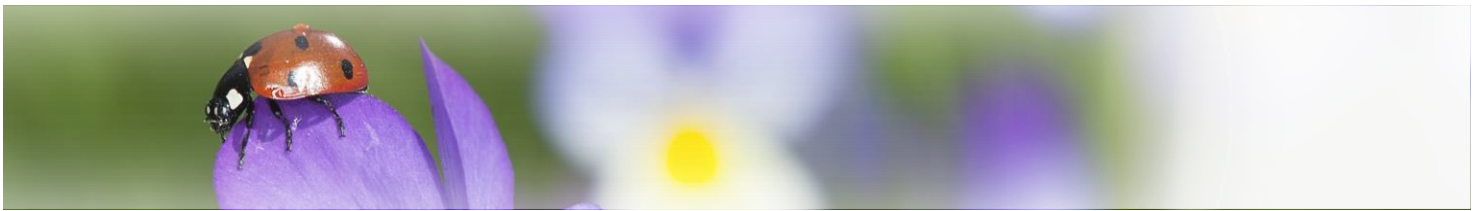

13 Contact

Sigmann DELTA GmbH
Beim Braunstall 4
D-97980 Bad Mergentheim

Tel. +49 (0) 9343 / 5890 - 74
Fax +49 (0) 6268 / 92899 - 74

info@sigmann-delta.de