



Operating Instructions

Trackball TBi

R. STAHL HMI Systems GmbH
Adolf-Grimme-Allee 8
50829 Köln

Version 01.00.06
Issue: 27.08.2018

Disclaimer

Publisher and copyright holder:

R. STAHL HMI Systems GmbH
Adolf-Grimme-Allee 8
D 50829 Köln

Registered place of business: Cologne
Court of registration: District court Cologne, HRB 30512
VAT number: DE 812 454 820

Phone: (switchboard) +49 (0) 221 76 806 - 1000
(hotline) - 5000
Fax: - 4100
E-mail: (switchboard) office@stahl-hmi.de
(hotline) support@stahl-hmi.de

- All rights reserved.
- This document may not be reproduced in whole or in part except with the written consent of the publisher.
- This document may be subject to change without notice.

Any warranty claims are limited to the right to demand amendments. Liability for any damage that might result from the content of this description or all other documentation is limited to clear cases of premeditation.

We reserve the right to change our products and their specifications at any time, provided it is in the interest of technical progress. The information in the current manual (in the internet and on CD / DVD / USB stick) or in the operating instructions included with the device applies.

Trademarks







The terms and names used in this document are registered trademarks and / or products of the companies in question.

Copyright © 2018 R. STAHL HMI Systems GmbH. Subject to alterations.

Specific markings

The markings in these operating instructions refer to specific features that must be noted.

In detail, these are:

 DANGER	This sign alerts users to hazards that will result in death or serious injury if ignored !
 WARNING	This sign alerts users to hazards that may result in death or serious injury if ignored !
 CAUTION	This sign alerts users to hazards that may damage machinery or equipment or result in injury if ignored !
 ATTENTION	Information highlighted by this symbol indicates measures for the prevention of damage to machinery or equipment !
 NOTICE	Information highlighted by this symbol indicates important information of which particular note should be taken !
 DOCUMENTATION	Information highlighted by this symbol refers to a different chapter or section in this manual or other documentation or a web-page !

Warnings



	<p style="text-align: center;">Caution !</p> In ambient temperatures exceeding +45 °C the surface of the devices may heat up. Caution when touching !
---	--

Table of contents

	Description	Page
	Disclaimer	2
	Specific markings	3
	Warnings	3
	Table of contents	4
1	Preface	5
2	Function	5
3	Conformity to standards	5
4	Certificates	6
4.1	ATEX	6
4.2	IECEX	6
5	Marking	6
6	Safety-related data	6
7	Ambient temperature range	6
8	Proof of intrinsic safety	7
8.1	General information	7
8.2	Interconnection	7
9	Safety Advice	9
9.1	Installation and operation	9
10	Assembly and disassembly	10
10.1	General information	10
10.2	View	10
10.3	Mechanical dimensions	11
10.3.1	Overview	11
10.3.2	Dimensional Drawing	11
10.4	Installation instructions	13
11	Operation	13
11.1	General information	13
11.2	Connections TBi	14
11.2.1	Connection cable	14
12	Maintenance, service	15
12.1	Servicing	15
12.2	Cleaning	15
13	Troubleshooting	15
14	Disposal	16
14.1	RoHS directive 2011/65/EC	16
14.1.1	China RoHS labelling	16
15	Certificates	17
15.1	Declaration of EC conformity	18
15.2	ATEX certification	19
15.3	IECEX certification	20
16	Release notes	21

1 Preface

These operating instructions are intended for the safe installation of the TBi trackballs and cover all Ex-relevant aspects. Furthermore, these operating instructions contain all necessary information for assembly and connection of the joysticks.

 NOTICE	All data relevant to explosion protection from the EC-type examination certificate were copied into these operating instructions.
	For the correct operation of all associated components please note, in addition to these operating instructions, all other operating instructions enclosed in this delivery as well as the operating instructions of the additional equipment to be connected !

2 Function

The type TBi trackballs are used to enter data, commands etc. on PCs and similar devices in hazardous areas.

The TBi-50-PS2 trackballs are explosion-protected equipment for installation in hazardous areas of zones 1 and 2. The devices may be connected to intrinsically safe PS2 interfaces. Power supply and data communication takes place via the PS2 interface. The trackballs are connected with a fixed cable.

The trackballs can be mounted inside a front panel or a desktop housing.

 NOTICE	When not operated (i.e. when the trackball is not moving) the trackball housing has IP65 (see also: section 10.4 Installation instructions).

3 Conformity to standards

The TBi trackballs comply with the following standards and the following directive:

Standard	Classification
ATEX Directive 2014/34/EU	
Initial certification	
EN 60079-0 : 2006	General requirements
EN 60079-11 : 2007	Intrinsic Safety ("i")
Electromagnetic Compatibility	
Directive 2014/30/EU	
EN 61326-1 : 2006	General requirements

4 Certificates

The TBi-50-PS2 trackballs are certified for installation in the following areas:

Europe:

according to ATEX Directive
for installation in zones 1 and 2

International / Australia:

IECEX (International Electrotechnical Commission System for Certification to Standards for Electrical Equipment for Explosive Atmospheres)

4.1 ATEX

The trackballs are ATEX-certified under the following number:

Certificate number: BVS 08 ATEX E 079

4.2 IECEX

The trackballs are IECEX-certified under the following number:

Certificate number: IECEX BVS 08.0031

 DOCUMENTATION	You can access all IECEX certificates on the official website of the IEC under their certificate number. http://iecex.iec.ch/iecex/iecexweb.nsf/welcome?openform
---	---

5 Marking

Manufacturer	R. STAHL HMI Systems GmbH	
Type code	TBi-50-PS2	
CE classification:	CE ₀₁₅₈	
Testing authority and certificate number:	BVS 08 ATEX E 079	
Ex classification:		
ATEX Directive		II 2 G Ex ib IIC T4
IECEX		Ex ib IIC T4

6 Safety-related data

U_i: 6 V
 I_i: 350 mA
 P_i: 1.2 W
 C_i: 13 µF
 L_i: negligible

7 Ambient temperature range

The temperature range is -20 °C ... +60 °C

8 Proof of intrinsic safety

Proof of intrinsic safety for the connection of Trackballs TBi with ET-/MT-xx6 HMI devices.

8.1 General information

Proof of intrinsic safety is based on the principles of IEC/EN 60079-14 and the standards referred to therein. Particular reference is made to Chapter 12 "Additional requirements for the type of protection i -intrinsic safety" in IEC/EN 60079-14.

Proof has been drawn up on the basis of conformity certification as per IEC/EN 60079-0 and IEC/EN 60079-11 or the EC type examination certificate in accordance with Directive 94/9/EC and the comparison of the safety-related data listed in these documents.

The following EC-type examination certificates were used:

<i>Device</i>		<i>EC type examination certificate</i>
ET-xx6	—	TÜV 05 ATEX 7176 X
MT-xx6	—	TÜV 07 ATEX 7471 X
ET-xx6-A	—	TÜV 11 ATEX 7041 X
MT-xx6-A	—	TÜV 11 ATEX 7103 X
TBi-50-PS2	—	BVS 08 ATEX E 079

The testing authority has listed **all** conditions applicable to intrinsic safety in the EC type examination certificates.

If an EC type examination certificate for a device only specifies the input voltage (U_i), for example, intrinsic safety is guaranteed if the associated supply does not exceed this voltage (U_o is less than / equals U_i).

Other output parameters specified in the examination certificate of the power supply (e.g. I_o , P_o) are in this case irrelevant to intrinsic safety.

NOTICE

The data given in this document do **NOT** absolve the fitter and / or operator of the systems from their obligation to ensure compliance with legal requirements, directives and regulations. Due diligence remains the sole responsibility of the fitter and / or operator !

8.2 Interconnection

In this part we list the voltages, currents, capacitance and inductance values of all circuits to determine whether the Trackballs TBi may be connected with a standard cable of 1.7 metres to the series 400 Open HMI - Panel PC's and series 500 Remote HMI - Thin Clients devices.

If the engineer or operator extends the track ball cable, the additional C and L cable values must be taken into account for the connection for proving intrinsic safety.

NOTICE

Please note that we cannot comment on the functionality of such a cable extension.

a) ET-/MT-xx6 HMI device with Trackball TBI

Source / active					==>	Acceptor / passive
ET-/MT-xx6						TBi-50-PS2
Terminal X9						Trackball connection
U _o = 5.9 VDC					≤	U _i = 6 VDC
I _o = 200 mA					≤	I _i = 350 mA
P _o = 1.18 W					≤	P _i = 1.2 W
C _{OIC} [μF] =	19	29	-	-	≥	C _i 13 μF
L _{OIC} [μH] =	2	1	-	-	≥	Li negligible
C _{OIB} [μF] =	13	23	46	86	≥	C _i 13 μF
L _{OIB} [μH] =	100	50	20	10	≥	Li negligible

C_o and L_o pairs directly above/underneath each other may be used.

b) ET-/MT-xx6-A HMI device with Trackball TBI-50-PS2
Circuits in zone 1

Source / active					==>	Acceptor / passive
ET-/MT-xx6-A						TBi-50-PS2
Terminal X9						Trackball connection
U _o = 5.88 VDC					≤	U _i = 6 VDC
I _o = 200 mA					≤	I _i = 350 mA
P _o = 1.18 W					≤	P _i = 1.2 W
C _{OIC} [μF] =	15.4	25.4	-	-	≥	C _i 13 μF
L _{OIC} [μH] =	2	1	-	-	≥	Li negligible
C _{OIB} [μF] =	20.4	43.4	82.4		≥	C _i 13 μF
L _{OIB} [μH] =	50	20	10		≥	Li negligible

C_o and L_o pairs directly above/underneath each other may be used.

c) MT-xx6-A HMI device with Trackball TBI-50-PS2
Circuits in zone 2

Source / active					==>	Acceptor / passive
MT-xx6-A						TBi-50-PS2
Terminal X9						Trackball connection
U _o = 5.88 VDC					≤	U _i = 6 VDC
I _o = 200 mA					≤	I _i = 350 mA
P _o = 1.18 W					≤	P _i = 1.2 W
C _{OIC} [μF] =	68.4	652.4	-	-	≥	C _i 13 μF
L _{OIC} [μH] =	2	1	-	-	≥	Li negligible
C _{OIB} [μF] =	33.4	53.4	102.4	222.4	≥	C _i 13 μF
L _{OIB} [μH] =	100	50	20	10	≥	Li negligible

C_o and L_o pairs directly above/underneath each other may be used.

9 Safety Advice

 NOTICE	This chapter is a summary of the key safety measures. The summary is supplementary to existing rules which staff also have to study.
	The safety of persons and equipment in hazardous areas depends on compliance with all relevant safety regulations. Thus, the installation and maintenance staff carry a particular responsibility, requiring precise knowledge of the applicable regulations and conditions.

 CAUTION	The notes listed below in section 9.1 must be heeded to avoid injury and damage to equipment !
--	--

9.1 Installation and operation

Please note the following when installing and operating the device:

- The national regulations for installation and assembly apply (e.g. IEC/EN 60079-14).
- The trackballs may be installed in zones 1 or 2.
- The TBi-50-PS2 trackball housing must be earthed via the PA connection (earthing screw) at the back of the housing !
- The trackballs with polyester membrane must be mounted in a position where they will not be exposed to direct UV light for extended periods of time.
- The intrinsically safe circuits must be installed according to applicable regulations.
- The trackball may only be operated when it is closed.
- When installed in zones 1 and 2, the trackballs may be connected to intrinsically safe input circuits.
- The safety values of the trackball must match those of the device to which it is connected.
- Interconnecting several active devices in an intrinsically safe circuit may result in different safe maximum values. This could compromise intrinsic safety !
- National safety and accident prevention rules.
- Generally accepted technical rules.
- Safety instructions contained in these operating instructions.
- Any damage may compromise the explosion protection.

Use the trackball for its intended purpose only (see "Function").

Incorrect or unauthorized use and non-compliance with the instructions in this manual will void any warranty on our part.

No changes may be made to the trackball that compromise explosion protection !

The trackball may only be installed and operated in an undamaged, dry and clean condition !

10 Assembly and disassembly

10.1 General information

! NOTICE

Assembly and disassembly are subject to general technical rules. Additional, specific safety regulations apply to electronic and pneumatic installations.

10.2 View

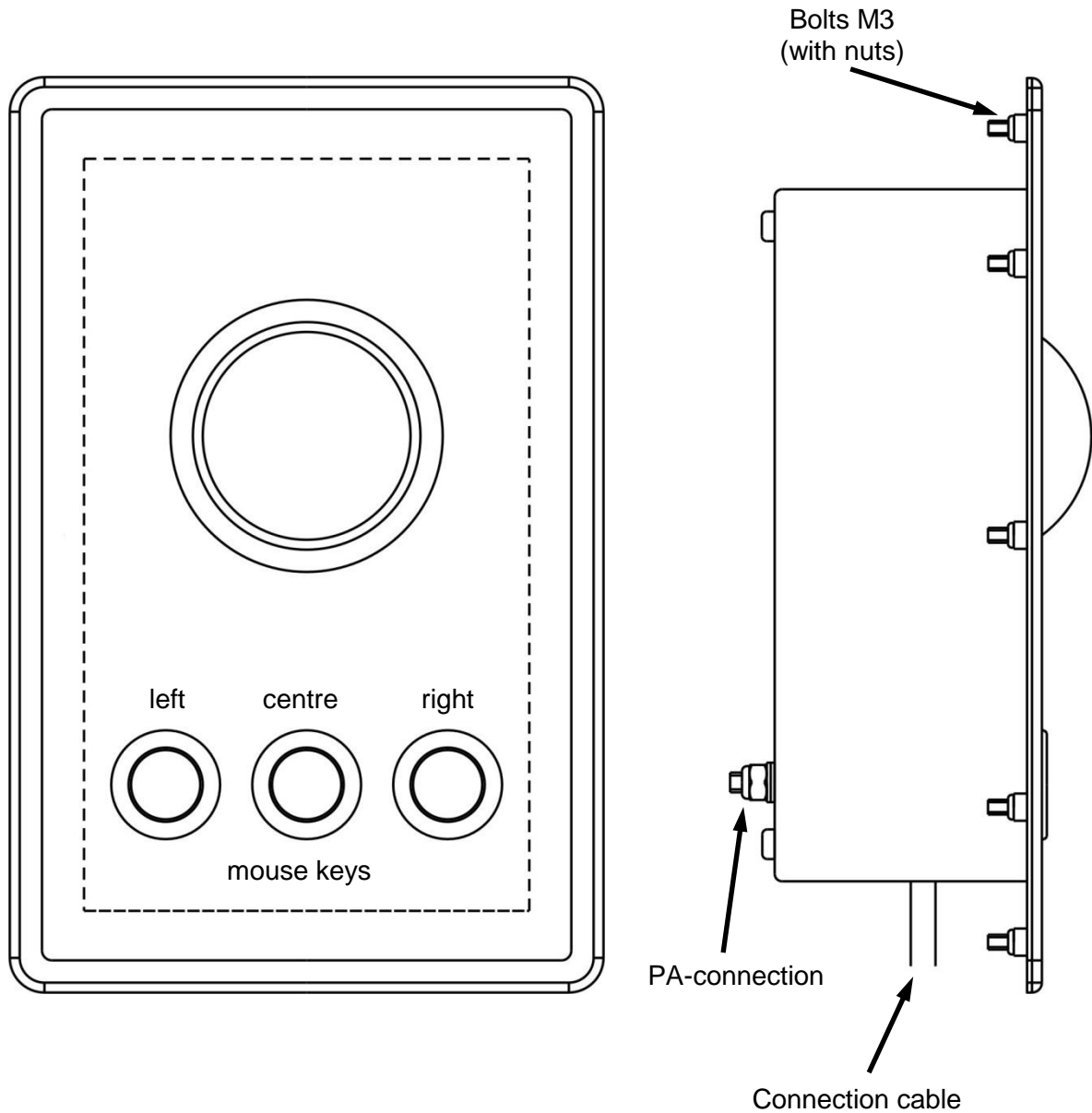

10.3 Mechanical dimensions

Dimensions in mm.

10.3.1 Overview

Trackball	Front plate (HxB)	Cut-out (HxB)	Hole pattern	Material thickness
TBi-50-PS2	185 x 120	152 x 90 (± 1)	see diagram	up to 6
	Depth of cut-out (depth)		Design Front (height)	
	60		13 (trackball height)	

10.3.2 Dimensional Drawing

Front view:

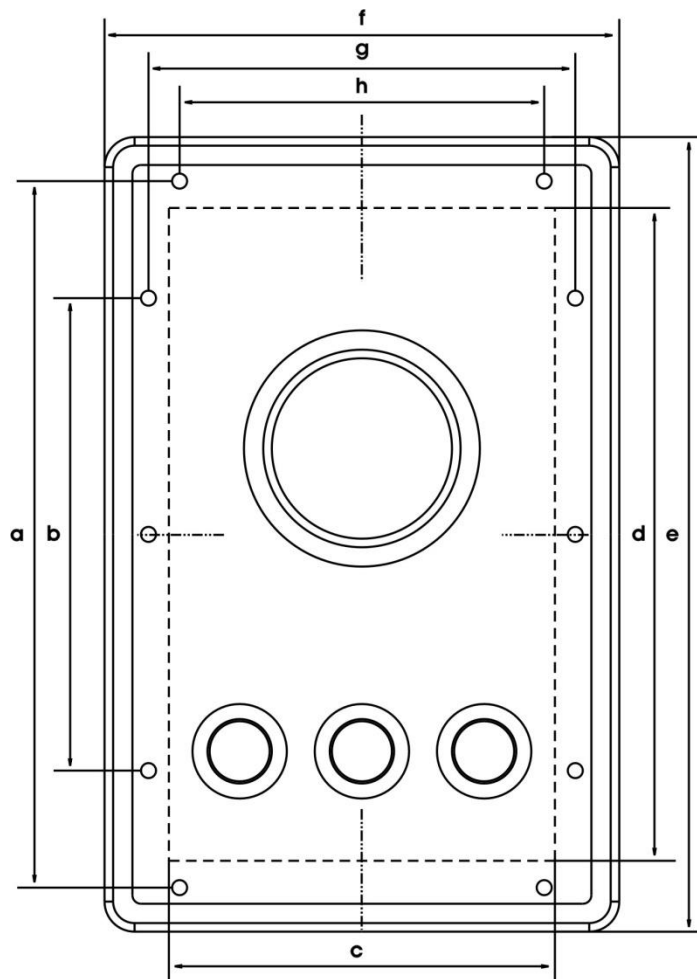

- e = Dimensions front plate height (h) = 185
- f = Dimensions front plate width (w) = 120
- c = Cut-out width (w) = 90 (± 1)
- d = Cut-out height (h) = 152 (± 1)
- a = Distance between holes drilled for mounting = 164.5
- b = Distance between holes drilled for mounting = 110
- g = Distance between holes drilled for mounting = 99.5
- h = Distance between holes drilled for mounting = 85

Side view:

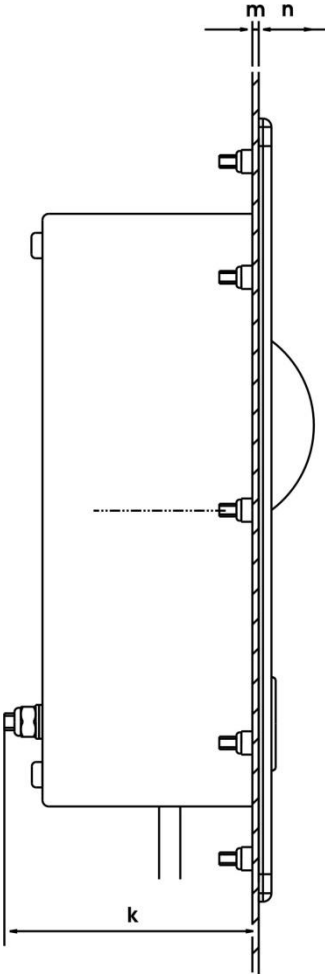

- k = Depth of cut-out = 60
- m = Material thickness = up to 6
- n = Design front height = 13

10.4 Installation instructions

The TBi-50-PS-2 trackball is intended for mounting in a desktop housing or front panel. The mounting position may be at any angle up to 90° to the horizontal.

If the TBi-50-PS2 has **NOT** been factory mounted, a cut-out of suitable size and a hole pattern must be made.

- Make a cut out with the following dimensions
152 (±1) mm (height) x 90 (±1) mm (width)
- Drill 10 holes with a diameter of 3.5 mm according to the hole pattern.
- Mount the trackball in the cut-out and use the self-locking nuts (10x M3) included in the delivery to attach the trackball.

 ATTENTION	<p>Optimum sealing:</p> <ul style="list-style-type: none"> • Tighten the nuts slightly. • Check the position of the trackball, ensuring above all that the rubber seals are correctly positioned. • Then tighten fully all self-locking nuts with a tightening torque of 0.1 - 1.5 Nm. • Connect the trackball cable according to the connection diagram to terminal X9 of the HMI device.
	<p>Earth:</p> <ul style="list-style-type: none"> • Connect the TBi-50-PS2 trackball housing to earth via the PA connection (earthing screw) at the back of the housing ! • The wire used must have a minimum cross section of 4 mm² !
	<p>Ingress protection:</p> <ul style="list-style-type: none"> • IP65 is only guaranteed if the trackball is not in motion ! When the trackball is in motion, ingress protection is reduced to IP54 ! <p>Please note that any water that might be on the trackball can reach the inside of the trackball housing when the trackball is moved. This may result in damage.</p>

11 Operation

11.1 General information

 NOTICE	<p>When operating the devices, particular care shall be taken that:</p> <ul style="list-style-type: none"> • the trackball has been properly installed according to instructions, • the trackball is undamaged, • all screws are tightened fast, • the connection cable is connected properly, • the trackball is connected to earth via the PA connection.
---	--

11.2 Connections TBi

The trackballs are fitted with a connection cable (standard length 1.7 m) that can be connected to the X9 terminal of the series 400 Open HMI - Panel PC's and series 500 Remote HMI - Thin Clients devices.

11.2.1 Connection cable

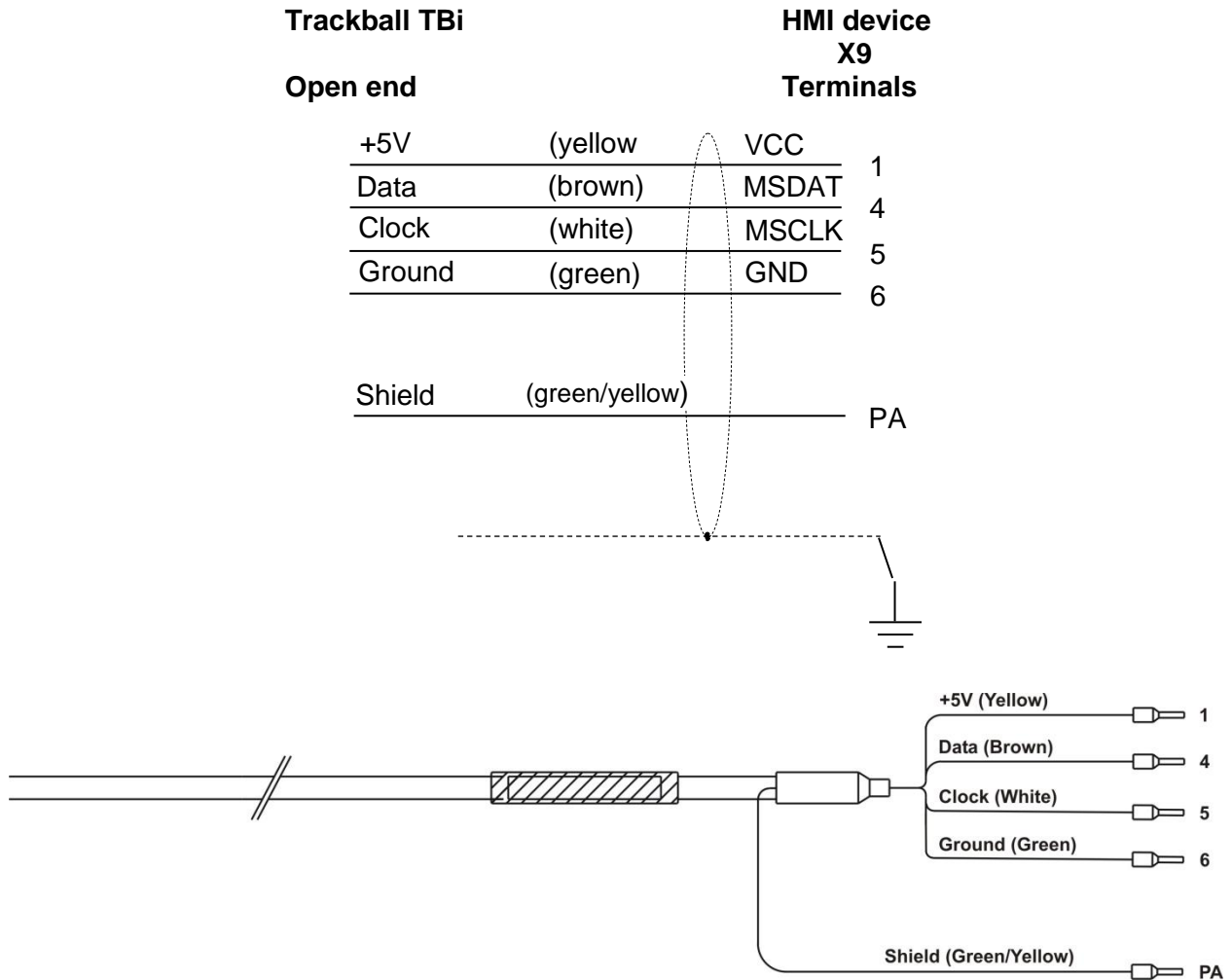

! ATTENTION The shielding connection (PE – green/yellow cable) must be connected to the PA terminal block of the HMIs !

12 Maintenance, service

! NOTICE

Associated equipment is subject to maintenance, service and testing according to guidelines 1999/92/EC, IEC/EN 60079-14, -17, -19 and BetrSichVer (Betriebssicherheitsverordnung - Occupational Safety and Health) !

Because the transmission of the trackballs remains reliable and stable over long periods of time, regular adjustments are not required.

Maintenance should focus on the following:

- Seal wear
- All cables and wires are properly connected and undamaged
- Housing damage

12.1 Servicing

It is the responsibility of the operator of electrical equipment in a hazardous environment to have this equipment serviced. Please also note the appropriate national rules and regulations.

12.2 Cleaning

Depending on where the trackball is in operation it may be necessary to clean the trackball occasionally. For this it is not necessary to deinstall or disassemble the trackball.

! NOTICE

Simply proceed as follows:

- The trackball may only be cleaned by qualified staff.
- Before cleaning the trackball switch off the connected operator interface.
- Only use special cleaning agents on an alcohol base (e.g. such as the ones used for keyboards) to clean the trackball.
- The cleaning agent must **NOT** be applied directly onto the trackball.
- Use a cotton-free cloth to apply the cleaning agent.
- Gently polish the surface of the trackball with this cloth.
- Move the trackball whilst cleaning it so that its entire surface is cleaned.
- Dry the trackball after cleaning it and before putting it back into operation.

13 Troubleshooting

Users cannot carry out any trackball repairs.

In addition, the following applies:

! NOTICE

Devices operated in hazardous areas must not be modified. Repairs may only be carried out by qualified, authorized staff specially trained for this purpose.

Repairs may only be carried out by specially trained staff who are familiar with all basic conditions of the applicable user regulations and – if requested – have been authorized by the manufacturer.

14 Disposal

Disposal of old electric and electronic devices, packaging and used parts is subject to regulations valid in whichever country the device has been installed.

For countries under the jurisdiction of the EU the corresponding WEEE directive applies.

The trackballs are classified according to the table below:

	old	new
Directive	WEEE I Directive 2002/96/EC	WEEE II Directive 2012/19/EU
Valid	until 14.08.2018	from 15.08.2018
Category	9 Monitoring and control devices	SG5 Small equipment <50 cm

We shall take back our devices according to our General Terms and Conditions.

14.1 RoHS directive 2011/65/EC

The revised version of the RoHS (restriction of hazardous substances) 2002/95/EC directive, directive 2011/65/EC, extends its area of application to all electric and electronic products.

The devices are conform with the requirements from RoHS directive 2011/65/EU, dated 03.01.2013.

14.1.1 China RoHS labelling

According to new Chinese legislation in force since 01.03.2007, all devices containing hazardous substances must be labeled accordingly.

The part of all toxic or hazardous substance contained in the homogeneous materials of the devices is below the limit stipulated in SJ/T11363-2006.

15 Certificates

 **NOTICE**

The chapter entitled "Certificates" contains only the first page of the EC type examination certificate plus the first page of the most recent supplement or other certifications.

All technical details contained in the EC type examination certificate are, however, part of these operating instructions.

The complete certificate can be downloaded from the internet at www.r-stahl.com or a copy can be ordered from R. STAHL HMI Systems GmbH.

15.1 Declaration of EC conformity

EU-Konformitätserklärung
EU Declaration of Conformity
Déclaration de Conformité UE



R. STAHL HMI Systems GmbH • Adolf-Grimme-Allee 8 • 50829 Köln, Germany
 erklärt in alleiniger Verantwortung, *declares in its sole responsibility, déclare sous sa seule responsabilité,*

dass das Produkt: **Trackball Module**
that the product:
que le produit:

Typ(en), type(s), type(s): **TBi-50-PS2**

mit den Anforderungen der folgenden Richtlinien und Normen übereinstimmt.
is in conformity with the requirements of the following directives and standards.
est conforme aux exigences des directives et des normes suivantes.

Richtlinie(n) / Directive(s) / Directive(s)		Norm(en) / Standard(s) / Norme(s)	
ATEX-Richtlinie ATEX Directive Directive ATEX	2014/34/EU 2014/34/EU 2014/34/UE	EN 60079-0: 2006 EN 60079-11: 2007	Das Produkt entspricht Anforderungen aus: <i>Product corresponds to requirements from:</i> <i>Produit correspond aux exigences:</i> EN 60079-0: 2012 EN 60079-11: 2012

Kennzeichnung, marking, marquage: **II 2 G Ex ib IIC T4**

CE 0158

EG/EU-Baumusterprüfbescheinigung: **BVS 08 ATEX E 079**
EC/EU Type Examination Certificate:
Attestation d'examen CE/UE de type:
DEKRA EXAM GmbH (ID0158)
 Dinnendahlstraße 9
 44809 Bochum
 Germany

EMV-Richtlinie **2014/30/EU**
EMC Directive **2014/30/EU**
Directive CEM **2014/30/UE**
 EN 61326-1: 2006

Produktnormen nach RoHS-Richtlinie (2011/65/EU): **EN 50581:2012**
Product standards according to RoHS Directive:
Normes des produit pour la Directive RoHS:

Köln, 2016-04-22

Ort und Datum
Place and date
Lieu et date

i.V.
J. Düren
 Technical Director

i.V.
W. Bertges
 Quality Manager

15.2 ATEX certification



Translation

(1) EC-Type Examination Certificate

- (2) **- Directive 94/9/EC -**
Equipment and protective systems intended for use
in potentially explosive atmospheres
- (3) **BVS 08 ATEX E 079**
- (4) **Equipment:** Trackball type TBi-50-PS2
- (5) **Manufacturer:** R. STAHL HMI Systems GmbH
- (6) **Address:** 50767 Köln, Germany
- (7) The design and construction of this equipment and any acceptable variation thereto are specified in the appendix to this type examination certificate.
- (8) The certification body of DEKRA EXAM GmbH, notified body no. 0158 in accordance with Article 9 of the Directive 94/9/EC of the European Parliament and the Council of 23 March 1994, certifies that this equipment has been found to comply with the Essential Health and Safety Requirements relating to the design and construction of equipment and protective systems intended for use in potentially explosive atmospheres, given in Annex II to the Directive.
The examination and test results are recorded in the test and assessment report BVS PP 08.2104 EG.
- (9) The Essential Health and Safety Requirements are assured by compliance with:
EN 60079-0:2006 General requirements
EN 60079-11:2007 Intrinsic safety 'i'
- (10) If the sign "X" is placed after the certificate number, it indicates that the equipment is subject to special conditions for safe use specified in the appendix to this certificate.
- (11) This EC-Type Examination Certificate relates only to the design, examination and tests of the specified equipment in accordance to Directive 94/9/EC.
Further requirements of the Directive apply to the manufacturing process and supply of this equipment. These are not covered by this certificate
- (12) The marking of the equipment shall include the following:

 **II 2G Ex ib IIC T4**

DEKRA EXAM GmbH

Bochum dated 11. July 2008



Signed: Migenda

Certification body

Signed: Hauke

Special services unit

15.3 IECEx certification

		<h2 style="margin: 0;">IECEX Certificate of Conformity</h2>	
<p>INTERNATIONAL ELECTROTECHNICAL COMMISSION IEC Certification Scheme for Explosive Atmospheres <small>for rules and details of the IECEx Scheme visit www.iecex.com</small></p>			
Certificate No.:	IECEX BVS 08.0031	issue No.:	1
Status:	Current	<div style="border: 1px solid black; padding: 2px;"> Certificate history: Issue No. 1 (2010-3-23) Issue No. 0 (2008-7-11) </div>	
Date of Issue:	2010-03-23	Page 1 of 4	
Applicant:	R. STAHL HMI Systems GmbH Im Gewerbegebiet Pesch 14 50767 Cologne Germany		
Electrical Apparatus: <i>Optional accessory:</i>	Trackball type TBI-50-PS2		
Type of Protection:	Intrinsic safety "i"		
Marking:	Ex ib IIC T4		
<i>Approved for issue on behalf of the IECEx Certification Body:</i>	Dr. F. Eickhoff		
<i>Position:</i>	Deputy Head of Certification Body		
<i>Signature: (for printed version)</i>	 <hr style="width: 100%;"/>		
<i>Date:</i>	<u>2010-03-23</u>		
<p>1. This certificate and schedule may only be reproduced in full. 2. This certificate is not transferable and remains the property of the issuing body. 3. The Status and authenticity of this certificate may be verified by visiting the Official IECEx Website.</p>			
Certificate issued by: DEKRA EXAM GmbH Dinnendahlstrasse 9 44809 Bochum Germany		 DEKRA DEKRA EXAM GmbH	

16 Release notes

The chapter entitled "Release Notes" contains all the changes made in every version of the Operating Instructions.

Version 01.00.06

- Removal of previous release notes
- Addition of section "Specific markings"
- Changing of all markings according to the new definition
- Adaption of section "Disposal" according to the current WEEE directive
- Formal changes

R. STAHL HMI Systems GmbH
Adolf-Grimme-Allee 8
D 50829 Köln

Phone: (switchboard) +49 (0) 221 76 806 - 1000
(hotline) - 5000
Fax: - 4100
E-mail: (switchboard) office@stahl-hmi.de
(hotline) support@stahl-hmi.de

www.r-stahl.com
www.stahl-hmi.de

