

Network technology

ISbus fieldbus technology Field device coupler, 4 spurs

for Zone 1 Ex e

9411/11-210-30 Art. No. 161849

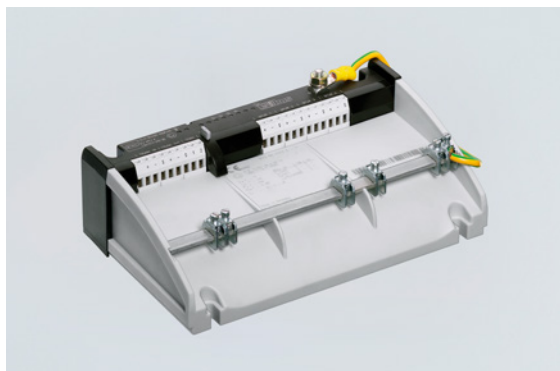

- For connecting 4 fieldbus devices in Zone 1
- Operation on a high-power trunk
- Reduced start-up current thanks to power management and short-circuit limiting with disconnection

MY R. STAHL 9411B



Series 9411/11 Ex e field device couplers for Zone 1 are used for interference-free connection of up to 4 Foundation Fieldbus H1 or PROFIBUS PA field devices to the high-power trunk. The spurs with the e type of protection can be used for fieldbus devices in Zone 1 (d, q, m) and are protected by a short-circuit limiting function. The integrated power management minimises start-up and short-circuit currents.

Available with screw or spring clamp terminals.

Technical Data

Explosion Protection	
Application range (zones)	22
Ex interface zone	1
IECEX gas certificate	IECEX BVS 08.0056X
IECEX gas explosion protection	Ex mb e IIC T4 Gb
ATEX gas certificate	BVS 06 ATEX E 003 X
ATEX gas certificate	BVS 06 ATEX E 003 X
ATEX gas explosion protection	Ⓔ II 2 G Ex mb e IIC T4 Gb
FMus certificate	3026646
cFM certificate	3026646C
Marking cFMus	NI, Class I, Div. 2, Groups A,B,C,D; T4, Class I, Zone 1, AEx/Ex m e IIC T4 T4 at Ta = 75°C See Doc. 9411 6 031 002 1
Certificates	ATEX (BVS), Brazil (ULB), Canada (FM), IECEX (BVS), International (FF), USA (FM)
Electrical Data	
Max. number of field devices per segment	16 (FF H1) 32 (Profibus PA)
Data transmission trunk and spurs	Passive No repeater function
Max. number of field device couplers	4 per trunk
Power Management	If the voltage on the trunk exceeds 9 V, the spurs are switched on consecutively in order to avoid a high start-up current through the field devices. If a spur short circuit is detected, the affected spur is disconnected until the short circuit is removed. The trunk is loaded with max. one short-circuit current, regardless of how many spurs are short-circuited. This minimises the current drawn by the trunk and the power dissipation under all operating conditions.

Electrical Data

Fieldbus termination	The field device couplers have a built-in, connectable terminator $100\ \Omega + 1\ \mu\text{F}$ (IEC 61158-2). A jumper between the TERM 1 and 2 terminals connects the terminator to the trunk. As an alternative, it is also possible to use a Series 9418 external terminator at the trunk OUT connection.
----------------------	--

Auxiliary Power

Max. power dissipation	1.1 W
Auxiliary power	Not required; the field device coupler is supplied with power from the trunk.

Galvanic Isolation

Galvanic separation spur/trunk	No galvanic separation
Galvanic separation spur/spur	No galvanic separation

Input

Trunk connections	2 (IN/OUT) Bridged internally
Trunk version	High power trunk/Ex e
Min. input voltage	10.7 V according to FF-846
Input voltage note	This ensures that the output voltage (spurs) is at least 9.3 V under full load.
Voltage range	9 – 32 V
Input undervoltage monitoring	< 9 V, spurs de-energised
Surge protection	Yes
Max. trunk voltage IN/OUT	2 A
Max. trunk voltage drop IN/OUT	$\leq 60\ \text{mV}$ at 2 A/25 °C
Trunk polarity reversal protection	Yes
Trunk earthing	Direct on shield bus Capacitive over 5.2 nF
Max. current consumption	0 mA per spur: 25 mA 20 mA per spur: 105 mA 41 mA per spur: 189 mA 3 or 7 spurs with 41 mA each, 1 spur in the short circuit: 198 mA Short circuit all spurs: 75 mA

Output

Max. number of field devices per spur	1
Max. cable length	120 m
Max. continuous output current DC	41 mA
Max. voltage drop trunk/spur	$\leq 1.4\ \text{V}$
Output max. short-circuit current	50 mA
Spurs earthing	Direct on shield bus Capacitive over 4.7 nF

Field Device Interface

Spurs version	Ex e
Spurs connections	4
Spurs connection type	Screw terminals

Device Specific Data

Trunk LED operating conditions	"RUN" LED, green
Spurs operating condition LED	"S1" to "S4" LED, yellow
Error detection	Short circuit ≥ 42 to 50 mA

Device Specific Data

Short circuit indication	"S1" to "S4" LED Yellow, flashes
Note	The R. STAHL "Fieldbus Wizard" tool (r-stahl.com) must be used for correct project engineering.

Diagnostics

LED group error	Red "ERR" LED, flashing
-----------------	-------------------------

Ambient Conditions

Ambient temperature	-40 °C ... 75 °C
Ambient temperature	-40°F ... +167°F
Storage temperature	-40 °C ... 75 °C
Storage temperature	-40°F ... +167°F
Max. operating altitude	< 2000 m
Max. operating altitude	2000 m
Max. operating altitude, ft	< 6562 ft
Max. relative humidity	95% (without condensation)
Max. relative humidity	95 %
Electromagnetic compatibility	Tested to the following standards and regulations: EN 61326 (IEC/EN 61000-4-1 to 61000-4-6 and 61000-4-11; EN 55022 class B), NAMUR NE21

Mechanical Data

Field enclosure	without
Trunk connection type	Screw terminals
Connection terminals	3-pole (+, -, shield)
Connection earthing	Shield bus; at terminal "S" (M6 earth bolt)
Rigid single-wire connection	Trunk 0.2 to 4 mm ² Spurs 0.2 to 4 mm ²
Flexible single-wire connection	Trunk 0.25 to 2.5 mm ² Spurs 0.25 to 2.5 mm ²
Flexible single-wire connection with sleeve	Trunk 0.25 to 2.5 mm ² Spurs 0.25 to 2.5 mm ²
Degree of protection (IP) (IEC 60529)	IP30 enclosure IP20 Ex e terminals
Module enclosure	PA 6.6
Fire resistance (UL 94)	HB
Pollutant class	Corresponds to G3
Width	208.5 mm
Width, inches	8.21 in
Height	82 mm
Depth	128.2 mm
Depth in inches	5.05 in
Mounting depth in inches	3.23 in
LED operating status Spurs des	S1 ... S4
Weight	2.03 lb

Mounting / Installation

Mounting type	on NS 35/15 DIN rail (DIN EN 60715) On mounting plate (4 x M5 screw)
---------------	---

Mounting / Installation

Tightening torque	2.6 Nm
Mounting orientation	Horizontal Vertical

Components

LED operating status Trunk des	RUN
LED operating status Trunk col	green

Technical Drawings – Subject to Alterations

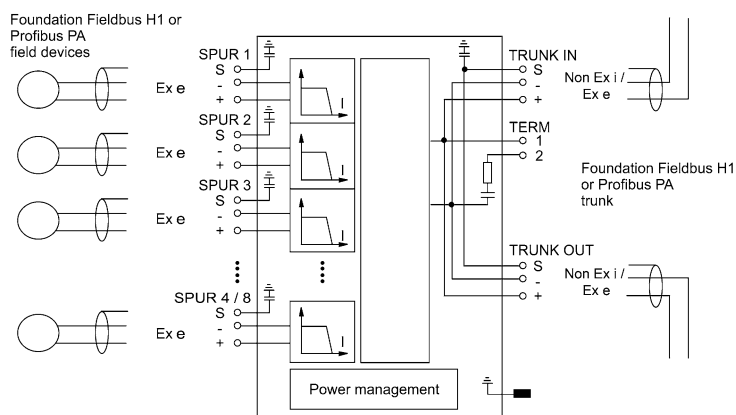

Connection diagram 9411/11

Dimensional Drawings (All Dimensions in mm [inches]) – Subject to Alterations

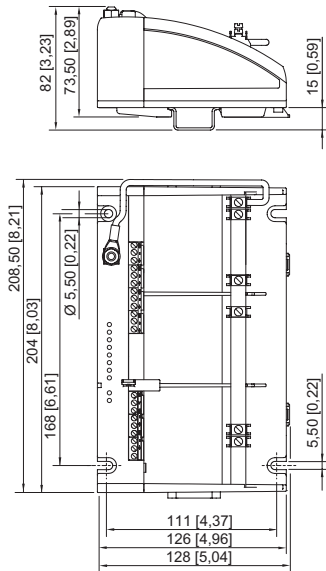

Field device coupler, 4 spurs, without enclosure

Accessories

Cable for Foundation Fieldbus, PROFIBUS PA

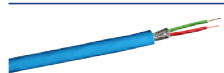

Cable type: O2YS(St+Ce)Y-fl
 Colour (sheath): Blue
 Application area: Universal use
 FISCO, UL listed, sunlight-resistant, oil-resistant, flame retardant

Art. No.

169328

Network technology



ISbus fieldbus technology Field device coupler, 4 spurs

for Zone 1 Ex e

9411/11-210-30 Art. No. 161849

Cable for FOUNDATION Fieldbus, PROFIBUS PA

Art. No.



Cable type: O2YS(St+Ce)Y-fl
Colour (sheath): Orange
Application area: Universal use
FISCO, UL listed, sunlight-resistant, oil-resistant, flame retardant

169329

Earthing rail set for 4 spurs

Art. No.



9411 earthing rail with spring clamp clips

202774

Fieldbus wizard engineering tool

Art. No.

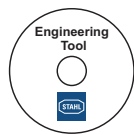

Engineering tool for project engineering for Foundation Fieldbus or PROFIBUS PA fieldbus segments
Download from r-stahl.com

We reserve the right to make alterations to the technical data, dimensions, weights, designs and products available without notice. The illustrations cannot be considered binding.