

Signalling devices

Visual signalling device XENON light fitting

In flameproof enclosure

FL60/334-D0111-00GW10-ST000-0000 Art. No. 321472



- The latest generation of audible and visual alarm devices
- Ex d/Ex e connection chambers
- Visual solutions with 5 J XENON and high-power LEDs with various light modes and 4 light channels
- Four output levels can be configured
- Brackets, fixings and protective grid made from stainless steel
- Fastening bracket and protective cage included

MY R. STAHL FL60D



The **FL60/3 product series** provides visual alarm signals which can be used to alert, warn or draw attention to equipment malfunction/start-up or any number of safety-related issues in hazardous areas. The preconfigured light patterns (LED) provide a wide range of internationally standardised signal patterns, whereby four channels are available for each, enabling flexible use.

Technical Data

Explosion Protection

Area of application	European Union (ATEX) IECEX
Application range (zones)	1, 2, 21, 22
IECEX gas certificate	IECEX EPS 22.0046 X
IECEX gas explosion protection	Ex db IIC T4 Gb
IECEX dust certificate	IECEX EPS 22.0046 X
IECEX dust explosion protection	Ex tb IIIC T100 °C Db
ATEX gas certificate	EPS 22 ATEX 1 224 X
ATEX gas explosion protection	⊕ II 2 G Ex db IIC T4 Gb
ATEX dust certificate	EPS 22 ATEX 1 224 X
ATEX dust explosion protection	⊕ II 2 D Ex tb IIIC T100 °C Db
Certificates	ATEX (BVIS), IECEX (BVIS)
Declaration of conformity	ATEX (EUK)

Electrical Data

Rated operational voltage DC	12 ... 27.2 V
Line monitoring	Yes

Lighting Data

Lamp	5 J xenon flash tubes
Effective luminous intensity (1 Hz, flashing)	23 cd

Ambient Conditions

Ambient temperature	-40 °C ... 60 °C (T4)
Storage temperature	-60 °C ... 70 °C
Humidity	95 %

Mechanical Data

IP degree of protection (IEC 60598)	IP66/67
Connection chamber version	Ex d

Signalling devices



Visual signalling device XENON light fitting

In flameproof enclosure

FL60/334-D0111-00GW10-ST000-0000 Art. No. 321472

Mechanical Data

Enclosure material	Aluminium, powder-coated, Seawater-resistant
Enclosure colour	red, similar to RAL 3020
Silicone-free content	Contains silicone
Material dome	Polycarbonate, prismatic
Material glass dome	Polycarbonate, prismatic
Protective collar material	Polycarbonate (PC cover)
Wire guard material	Stainless steel
Max. solid connection terminals	4 mm ²
Max. finely stranded connection terminals	2.5 mm ²
Clamping range	0.5 ... 4 mm
Width	176 mm
Height	317 mm
Length	128 mm
Lens colour	Green
Mounting	L-bracket
Weight	5.86 kg
Weight	12.92 lb

Mounting / Installation

Connection type	Push in
Mounting part material	Stainless steel

Components

Drilled holes	2x M20 + 2x 1/2"
Stopping plugs	2x M20 + 2x 1/2"
Stopping plug material	Nickel-plated brass

Dimensional Drawings (All Dimensions in mm [inches]) – Subject to Alterations

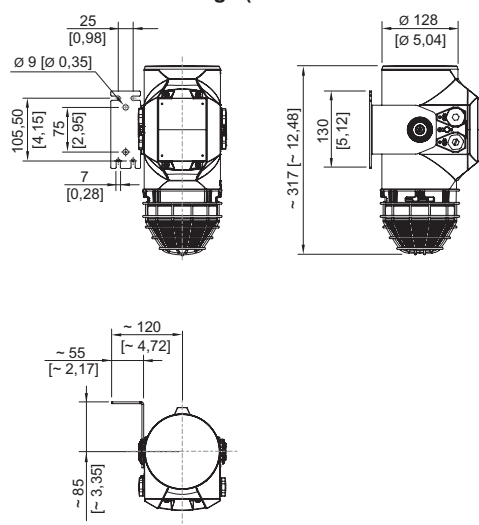

Signalling devices

Visual signalling device XENON light fitting

In flameproof enclosure

FL60/334-D0111-00GW10-ST000-0000 Art. No. 321472



Accessories

Metal cable gland

Art. No.

	Ex d and Ex e cable gland with compound for all types of armoured cables (SWA, wire-braid, tape) (nickel-plated brass) Type 20PX2K, M20 x 1.5	109428
	Ex d and Ex e cable glands with RapidEx sealing system for all types of unarmoured cables and wire-braid-armoured cables (nickel-plated brass) Type 20PX2K-REX, M20 x 1.5	246649
	Ex d and Ex e cable glands with compound for all types of unarmoured cables and wire-braid-armoured cables (nickel-plated brass) Type 20PXSS2K, M20 x 1.5	109441
	Ex d and Ex e cable glands with RapidEx sealing system for all types of unarmoured cables and wire-braid-armoured cables (nickel-plated brass) Type 20PXSS2K-REX, M20 x 1.5	246605

Plastic cable gland

Art. No.

	8161/7-M20-1304, Ex e Polyamide, M20 x 1,5 mm, 4 – 13 mm Lot size 50 pieces	239156
--	---	--------

Stopping plug

Art. No.

	8290/3-M20 Plastic, M20 x 1.5 Lot size 1 piece	143522
	8290/3-M20 Plastic, M20 x 1.5 Lot size 100 pieces	285773

Spare Parts

Mounting accessories

Art. No.

	L-bracket, stainless steel 1.4404	319271
	U-bracket, stainless steel 1.4404	319280

Protective cage

Art. No.

	Protective cage, stainless steel 1.4404	319272
--	---	--------

Signalling devices



Visual signalling device XENON light fitting

In flameproof enclosure

FL60/334-D0111-00GW10-ST000-0000 Art. No. 321472

Textured lens

		Art. No.
	green	319275

We reserve the right to make alterations to the technical data, dimensions, weights, designs and products available without notice. The illustrations cannot be considered binding.