

Isolator Barriers

Frequency transmitter

Ex i field circuit

9146/20-11-11s Art. No. 159886



- Compact Ex i frequency transmitter for monitoring rotational speed in hazardous areas
- Limit value analysis + frequency-current conversion + pulse divider function over a width of just 17.6 mm
- Parameterization made easy by "ISpac Wizard" software

MY R. STAHL 9146A



9146 series Ex i- frequency transmitters monitor the speed of rotating parts on one or two channels, e.g. the speed of fans or centrifuges. The frequency measured at the intrinsically safe input (between 0.001 Hz and 20 kHz) is issued as a unit signal (0/4 mA to 20 mA) or processed by a frequency divider. In single-channel devices, these frequency transmitters check whether speeds have exceeded or fallen below the limit values.

Technical Data

Explosion Protection	
Application range (zones)	2
Ex interface zone	0, 1, 2, 20, 21, 22
IECEX gas certificate	IECEX BVS 13.0095 X
IECEX gas certificate	IECEX BVS 13.0095 X
IECEX gas explosion protection	Ex ec nC [ia Ga] IIC T4 Gc
IECEX dust certificate	IECEX BVS 13.0095 X
IECEX dust explosion protection	[Ex ia Da] IIIC
IECEX firedamp certificate	IECEX BVS 13.0095 X
IECEX firedamp protection	[Ex ia Ma] I
ATEX gas certificate	BVS 05 ATEX E 0171 X
ATEX gas certificate	BVS 05 ATEX E 0171 X
ATEX gas explosion protection	⊕ II 3 (1) G Ex ec nC [ia Ga] IIC T4 Gc
ATEX dust certificate	BVS 05 ATEX E 0171 X
ATEX dust explosion protection	⊕ II (1) D [Ex ia Da] IIIC
ATEX firedamp certificate	BVS 05 ATEX E 0171 X
ATEX firedamp protection	⊕ I (M1) [Ex ia Ma] I
FMus certificate	FM16US0122X
cFM certificate	FM16CA0067X
Marking cFMus	Class I, Div. 2, Groups A,B,C,D; Class I, Zone 2, AEx/Ex nA nC Group IIC AIS Class I,II,III, Div. 1, Groups A,B,C,D,E,F,G; Class I, Zone 0, [AEx ia]/[Ex ia] IIC T4 at Ta = 70°C See Doc. 9146 6 031 001 1
Certificates	ATEX (BVS), Canada (FM), IECEX (BVS), India (PESO), USA (FM)
Ship approval	CCS, EU RO MR (DNV)
Declaration of conformity	ATEX (EUK)

Isolator Barriers

Frequency transmitter

Ex i field circuit

9146/20-11-11s Art. No. 159886



Safety Data

Max. voltage U_o/V_{oc}	10.5 V				
Max. current I_o/I_{sc}	23.4 mA				
Max. power P_o	61.4 mW				
Max. permissible external capacitance C_o/C_a for IIC	2.41 μ F				
Max. permissible external inductance L_o/L_a for IIC	63 mH				
Max. permissible external capacitance C_o/C_a for IIB	16.8 μ F				
Max. permissible external inductance L_o/L_a for IIB	230 mH				
Max. permissible external capa.IIA	75 μ F				
Max. permissible external inductance L_o for IIA	450 mH				
Max. permissible external capacity C_o for IIIC	16.8 μ F				
Max. permissible external inductance L_o for IIIC	230 mH				
Max. permissible external capacity C_o for I	95 μ F				
Max. permissible external inductance L_o for I	600 mH				
Internal capacitance	Negligible				
Internal inductance	Negligible				
Safety-related max. voltage	253 V				
Intrinsically safe limiting values inductance L_o /capacitance C_o	Jointly connectable inductance L_o /capacitance C_o				
IIC	L_o [mH]	20 mH	5 mH	1 mH	0.200 mH
	C_o [μ F]	0.490 μ F	0.670 μ F	0.960 μ F	1.400 μ F
IIB	L_o [mH]	100 mH	20 mH	2 mH	0.500 mH
	C_o [μ F]	1.900 μ F	2.700 μ F	4.500 μ F	6.400 μ F
IIA	L_o [mH]	100 mH	10 mH	1 mH	0.100 mH
	C_o [μ F]	2.900 μ F	4.500 μ F	7.300 μ F	14 μ F
IIIC	L_o [mH]	100 mH	20 mH	2 mH	0.500 mH
	C_o [μ F]	1.900 μ F	2.700 μ F	4.500 μ F	6.400 μ F
I	L_o [mH]	100 mH	10 mH	2 mH	0.100 mH
	C_o [μ F]	4 μ F	5.700 μ F	7.800 μ F	17 μ F

Electrical Data

Number of channels	2
LFD relay	Yes
Max. short-circuit current	8.5 mA
Parameterisation	With parameterising set 9199/20-02

Auxiliary Power

Auxiliary power	24 V DC
Auxiliary power voltage range	18 ... 31.2 V
Voltage range residual ripple	$\leq 3,6 V_{SS}$
Nominal current	75 mA

Isolator Barriers

Frequency transmitter

Ex i field circuit

9146/20-11-11s Art. No. 159886



Auxiliary Power

Max. power dissipation	1.5 W
Polarity reversal protection	Yes
Undervoltage monitoring	Yes
Operation indication	LED

Galvanic Isolation

Test voltage as per standard	EN IEC 60079-11
Ex i input to output	1.5 kV AC
Ex i input to auxiliary power	1.5 kV AC
Ex i input to fault message contact	1.5 kV AC
Ex i input to parameterisation interface	1.5 kV AC
Test voltage as per standard	EN 50178
Output to auxiliary power	350 V AC
Output to output	350 V AC
Output to parameterisation interface	350 V AC
Fault message contact to auxiliary power	350 V AC
Fault message contact to output	350 V AC

Input

Input signal	As per EN 60947-5-6 (NAMUR)
Input current for ON	≥ 2.1 mA
Input current for OFF	≤ 1.2 mA
Hysteresis	Approx. 0.2 mA
Input internal resistance R_i	1000 Ω
Input for open-circuit voltage U_a	8,5 V
Short-circuit current	≤ 8.5 mA
Input frequency	0.0010 – 20000 Hz
Pulse length/pause	25 μ s
Input for centre resolution note	< 0.1 % of measuring range

Output

Output signal	0/4 to 20 mA
Function range output	0 – 20.5 mA
Load resistance R_L	0 ... 600 Ω
Operating modes	Counter, period measurement, variable gate time
Limit contact (per channel)	without
Pulse output	without
LF switch user adjustment	Activated/deactivated
Wire breakage error detection input	$I_E < 0.05$ to 0.35 mA
Short circuit error detection input	$R_E < 100$ to 360 ohm
Behaviour of the output at line fault	configurable
Behaviour of the output at line fault note	with deactivated line fault: Short circuit: 3.8 mA, wire breakage: 20.5 mA
Line fault indication	LED
Fault message contact switching capacity	30 V / 100 mA
Line fault and loss of power signalization	- Contact (30 V/100 mA), closed against earth in case of error - pac-Bus, potential-free contact (30 V/100 mA)
Deviations / error note	Information in % of the measuring range (20 mA) at U_N , 23 °C

Isolator Barriers

Frequency transmitter

Ex i field circuit

9146/20-11-11s Art. No. 159886



Output

Average measurement fault	≤ 0,1%
Temperature influence	≤ 0,05% / 10 K

Ambient Conditions

Ambient temperature °C	-40 °C ... +70 °C (Single device) -40 °C ... +60 °C (Group assembly)
Ambient temperature °F	-40 °F ... +158 °F (Single device) -40 °F ... +140 °F (Group assembly)
Note	The installation conditions affect the ambient temperature. Observe the "Cabinet installation guide".
Storage temperature °C	-40 °C ... +80 °C
Storage temperature °F	-40 °F ... +176 °F
Max. relative humidity	95%
Use at the height of	< 2000 m
Electromagnetic compatibility	Tested to the following standards and regulations: EN 61326-1 For use in industrial areas; NAMUR NE 21

Mechanical Data

Degree of protection (IP)	IP30
Degree of protection (IP) terminals	IP20
Fire resistance (UL 94)	V0
Enclosure material	Polyamide
Grid dimension	17.6 mm
Width	17.6 mm
Width, inches	0.69 in
Height	114.5 mm
Height in inches	4.51 in
Length	108 mm
Length in inches	4.25 in
Weight	135 g
Weight	0.3 lb

Mounting / Installation

Mounting type	DIN rail NS35/15, NS35/7.5
Mounting orientation	Vertical Horizontal
Connection type	Screw terminal
Min. rigid conductor cross section	0.2 mm ²
Max. rigid conductor cross section	2.5 mm ²
Min. flex conductor cross section	0.2 mm ²
Max. flex conductor cross section	2.5 mm ²
Connection cross-section AWG	24 ... 14

Isolator Barriers

Frequency transmitter



Ex i field circuit

9146/20-11-11s Art. No. 159886

Technical Drawings – Subject to Alterations

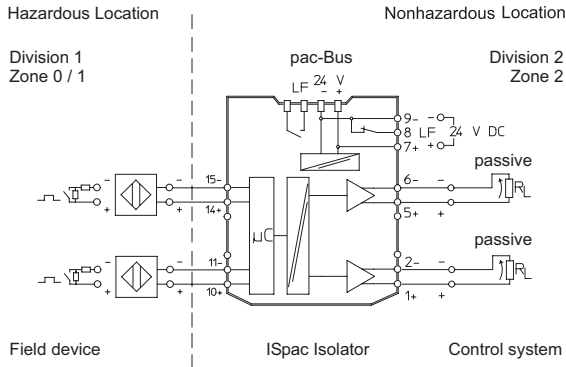

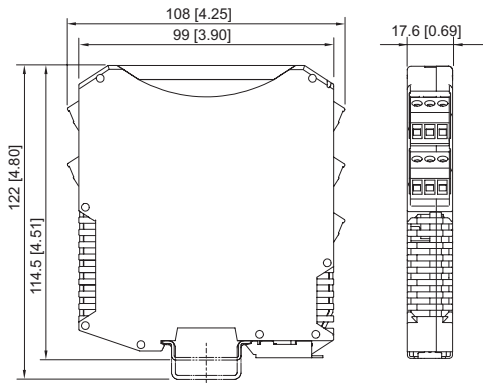

Connection diagram 9146/20-11-11

Dimensional Drawings (All Dimensions in mm [inches]) – Subject to Alterations



ISpac Series 9143, 9146, 9147, 9160, 9162, 9163, 9165, 9167, 9170, 9172, 9175, 9176, 9180, 9182, 9193, ISbus Series 9412 with screw terminal

Accessories

9146 Parameterisation		Art. No.
	Parameterisation ex works optionally available for all variants.	270534
Parameterization set ISpac - Wizard		Art. No.
	The software serves for commissioning, configuring and diagnosing the ISpac isolators Series 9146, 9162, 9182 and 9282. For further information, see operating instructions. Form of delivery: USB stick; parameterization software incl. parameterization cable / adaptor System requirements: IBM compatible PC with MS XP, Vista, Windows 7, 10 RS 232 C interface RS 232 / USB adaptor	202595
Resistive coupling element		Art. No.
	The 0/4 to 20 mA signal of channel 1 is converted to a 0/2 to 10 V signal. The resistive coupling element replaces the existing connection terminal. (Set with 5 pieces)	273968

Isolator Barriers

Frequency transmitter

Ex i field circuit

9146/20-11-11s Art. No. 159886

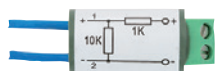

Additional connection of contacts also in hazardous areas to enable short-circuit and wire breakage detection

105944

We reserve the right to make alterations to the technical data, dimensions, weights, designs and products available without notice. The illustrations cannot be considered binding.