

Engineering Guideline

pac- Carriers Type 9195

Universal

Integration of conventional process automation interfaces – pac- Carrier

The pac- Carrier reflects the intention of R. STAHL to provide state-of-the-art concepts tailored to the needs of process automation and machine manufacturing. It is designed to reduce the cost of installation by space saving compact design and simplified installation. The Ex i/I.S. isolators can be mounted without the need for a tool. The intrinsically safe signal is directly connected to the modules by means of two different types of detachable connectors - screw type or cage clamp type. The connection to the control system I/O module is simply done by connecting a customer specific cable to the screw terminal of the pac- Carrier or Sub-D connectors (depend of type). The use of the pac- Carrier reduces the required time for installation and enables pre-wiring for later upgrades.

Your benefits:

- The most flexible system for the integration of Ex i/I.S. signals
- Complete line fault transparency - no blind spots
- Compact and rugged installation
- Pre-wiring enables easy and fault proved upgrade
- Systems for installation in hazardous location for the control system and Ex i/I.S. isolation made by STAHL

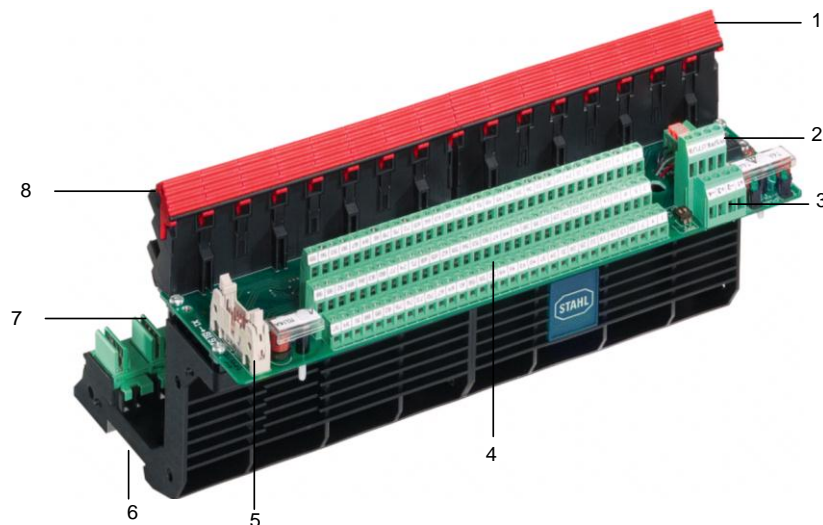

Example of 16 Slots Carrier

1. Ejector mechanism
2. Redundant and fused supply
3. Power supply failure and line fault signaling via relay contact
4. Interface for field signal connection across Ex i/I.S. isolator
5. Connector for HART Multiplexer type 9192/32
6. Installation on DIN rail or mounting plate
7. Integrated pac bus for power supply and line-fault signaling
8. Reliable snap-in mechanism, without tool

HART-Multiplexer Type 9192

Basic function: multiplexer for HART field devices, 32 channels. The HART-Multiplexer type 9192 is used for digital connection of up to 32 HART-capable field devices, such as transmitters and regulating valves, to a PC. The PC communicates with the HART-Multiplexer via an RS 485 bus. The software PDM allows configuration and diagnostics of all connected HART-capable field devices, plus continuous documentation of the process variables and status.

Interconnection:

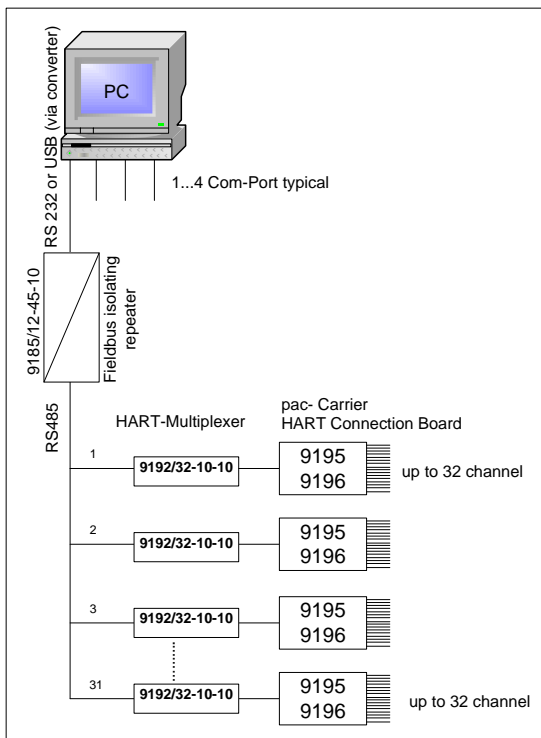

Accessories and Spare Parts

Designation	Description	Order number
Fieldbus isolating repeater	<ul style="list-style-type: none"> Adjustable baud rate (1.2 kBit/s up to 1.5 MBit/s) Power supply 24 V AC/DC 	9185/12-45-10s
pac- Carrier	8 slots, HART	9195/08H-....-...
	16 slots, HART	9195/16H-....-...
Connection board	for none Ex-applications, HART, 16 channels	9196/16H-XX0-...

Daisy chaining of several pac- Carriers to one HART-Multiplexer:

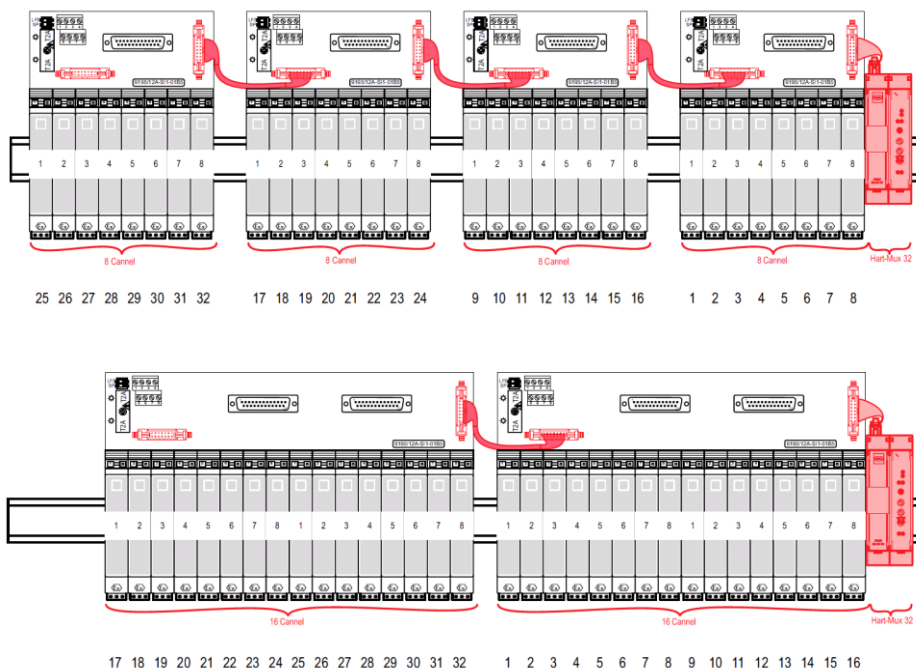



Point to Point Solutions

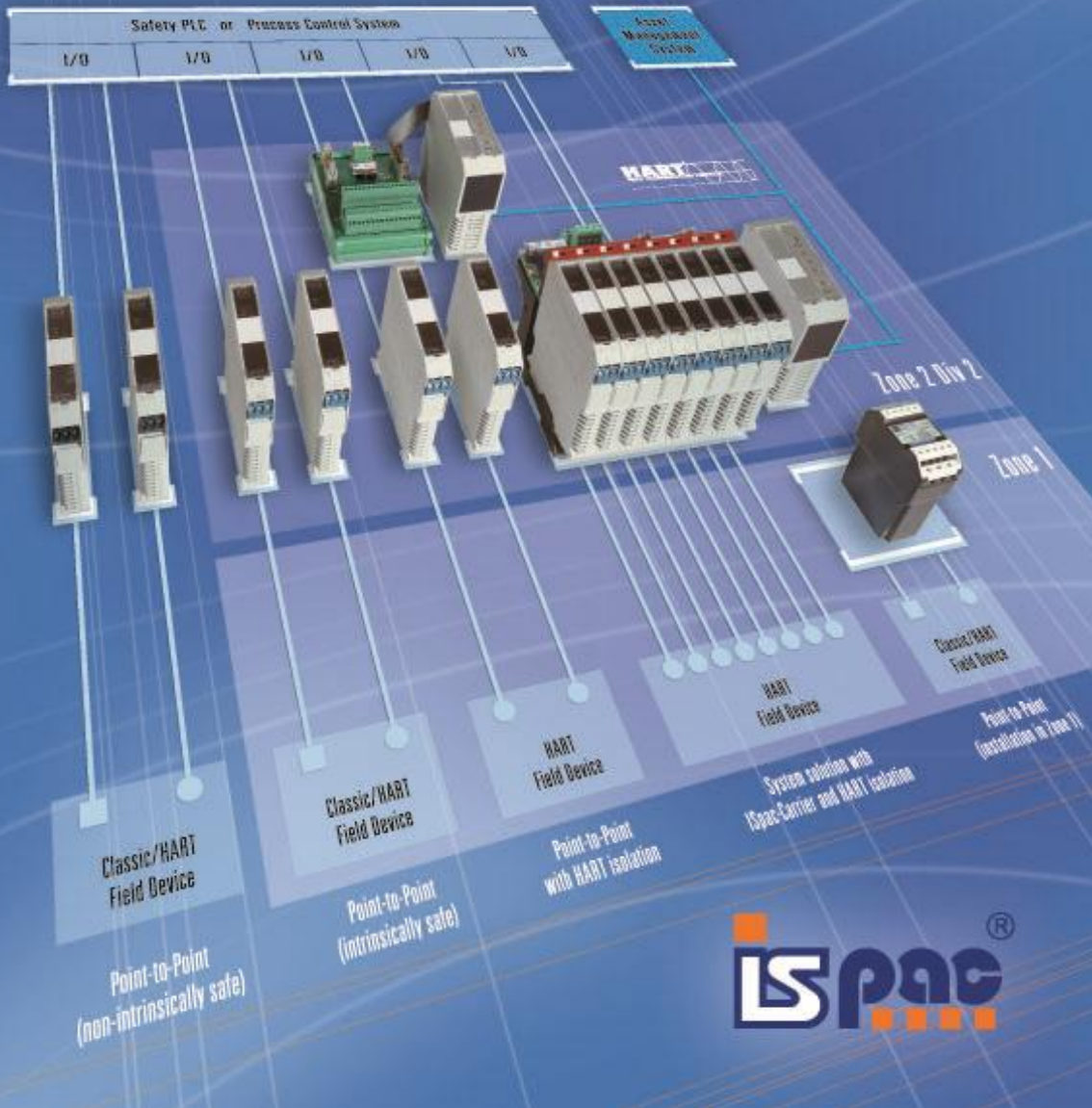

Content

Control system		pac- Carrier					
Signal type	Channels	Slots	Stahl cable type	HART-MUX	pac- Carrier type	ISpac	page
DI, DO, AI AO	32	16	without	9192/32	9195/16H-XX0-01C	ALL	7-11
	16	8	9195/C-007	NO	9195/08A-EP1-05A5	ALL	13-17
	32	16	9195/C-007	NO	9195/16A-XX0-03B3	ALL	19-23



pac- Carrier
9195/16H-XX0-01C

- Signal types: AI / AO / DI / DO
- pac-Carrier for 16 modules, up to 32 signals
- All ISpac isolators can be mounted
- Connection to HART-management systems
- Redundant power supply with fault signalization contact and exchangeable fuses
- Horizontal or vertical installation
- Simple installation on DIN rail or mounting plate
- Many labeling possibilities
- Fast and secure installation of the isolators without tools
- Comfortable exchange of the isolators with secured ejector mechanism
- Installation possible in Zone 2, Zone 22 (non conductible dust) and Div. 2

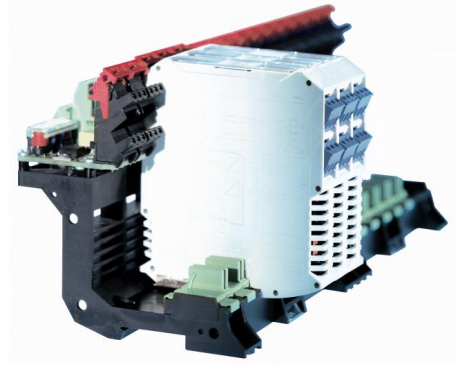

05179E00

Comfortable and simple integration of the Ex i/I.S. isolators ISpac. Flexible wiring possibilities on the system side with screw terminals.

System overview

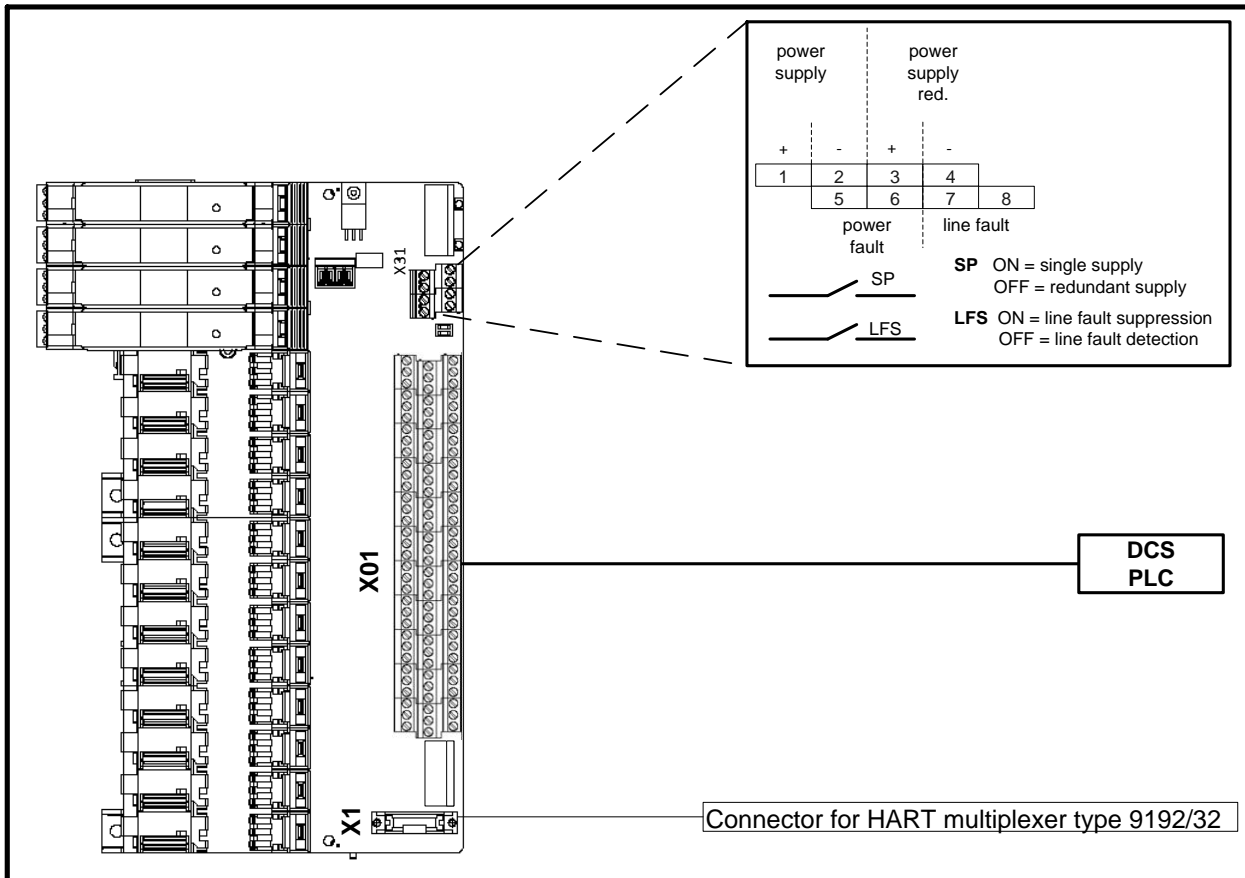

Selection table

Control system			pac- Carrier				
DCS manufacturer	DCS type	I/O-cards type	Slots	Channel	HART-MUX	Redundancy	Type
all	all	AI / AO/ DI / DO	16	32	9192/32	no	9195/16H-XX0-01C

Technical data

Certificates	BVS 03 ATEX E213 X
Explosion protection	⊕ II 3 G Ex nA nC II T4
Installation	In Zone 2, Zone 22 (non conductible dust), Div. 2 and in the safe area
Power supply	(X31)
Nominal voltage U_N	24 V DC (19 V ... 31,2 V)
Redundant supply	yes, decoupled with diodes
Indication	2 LED green „PWR1“; „PWR2“
Fuse	2 x TR5; T 2,0 A; exchangeable, for primary and redundant supply
Polarity reversal protection	yes
Connection field devices	
Connection	at the terminals of the Ex/I.S. isolators (see “signal loops”)
Number of channels	32
Connection automation system	(X01)
Connection	Customer specific cable
Number of channels	up to 32
Error messaging	(X31)
Power supply failure PF	Contact (35 V / 100 mA), closed in good conditions
Line fault LF (of ISpac modules)	Contact (35 V / 100 mA), closed in good conditions
Setting switch „SP“	Power failure message suppressed for redundant supply (single supply)
Setting switch „LFS“	Line fault message suppressed
Ambient conditions	
Ambient temperature	max. - 20 °C ... + 70 °C (see specification of the Ex i/I.S. isolators)
Storage temperature	- 40 °C ... + 80 °C
Relative humidity (no condensation)	≤95 %
Mechanical data	
Weight	approx. 320 g
Mounting type	on DIN rail or mounting plate (4 x screw M6)
Mounting position	horizontal or vertical
Casing / Terminal protection class	IP 00 / IP 20
Casing material	PA 6.6
Fire protecting class (UL-94)	V0



Signal loops

The diagrams below show typical applications. Please refer to the connection list to get the entire connection scheme. Basic technical parameters of the ISpac isolating repeaters can be found at the end of this document. The detailed specifications can be downloaded at: www.ispac.info.

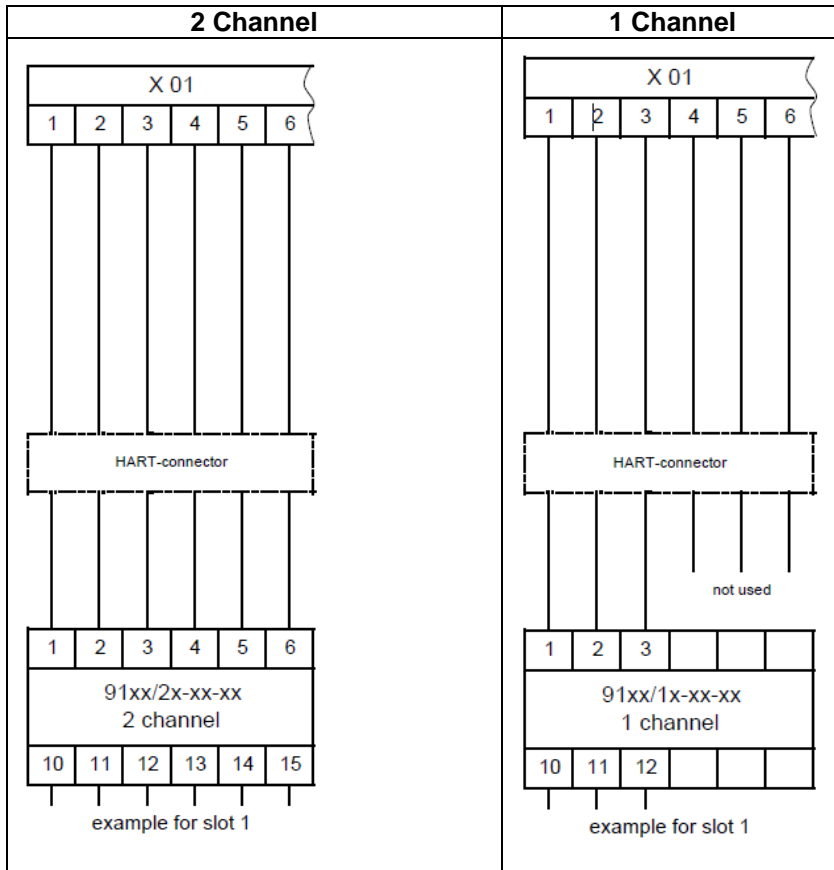
We offer for types 9146, 9162 und 9182 compact trip amplifier with 2 configurable limit values



Accessories and Spare Parts

Designation	Illustration	Description	Order number
Non-Ex i Termination Module	 06314E00	The termination module is used to integrate non-Ex i field circuit into the system integration solution pac- Carrier type 9195. In such a way it enables a flexible mixture of Ex i and non-Ex i field circuits.	9191/20-00-50s
HART-Multiplexer	 09731E00	<ul style="list-style-type: none"> • Used for digital connection of up to 32 HART-capable field devices to an HART management system • Installation possible in Zone 2 and Div. 2 • Can be used up to SIL 3 (IEC 61508) • The Device DTM is used to transmit HART information between HART compatible field devices and a FDT frame application such as FieldCare or PactWare™ 	9192/32-10-10
Fuse		Fuse T2,000A 250 V TR5. Minimum order is 10 pieces	111336

Dimension drawings (all dimensions in mm) - subject to alterations

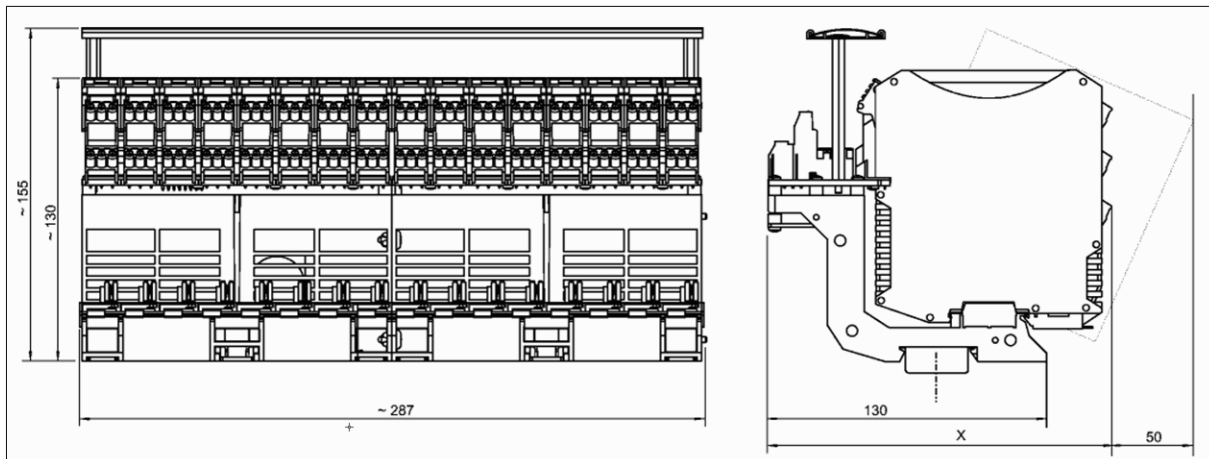

12472E00

	Dimension x
Screw terminals	176 mm
Cage clamp terminals	186 mm

Please note: In order to snap in the ISpac modules an extra space of approx. 50 mm is required. Please read the "ISpac engineering guideline" carefully before you start to engineer the enclosures with incorporated ISpac modules with or without pac- Carriers. The "ISpac engineering guideline" can be downloaded from: www.ispac.info.



Connection list

Connection to field devices (Ex i / I.S.)

notes	i.s terminal module	slot no.	terminal module	terminal X 01	notes	i.s terminal module	slot no.	terminal module	terminal X 01
*1	10	1	1	1	*1	10	9	1	49
	11		2	2		2		50	
	12		3	3		3		51	
	13		4	4		4		52	
	14		5	5		5		53	
	15		6	6		6		54	
*1	10	2	1	7	*1	10	10	1	55
	11		2	8		2		56	
	12		3	9		3		57	
	13		4	10		4		58	
	14		5	11		5		59	
	15		6	12		6		60	
*1	10	3	1	13	*1	10	11	1	61
	11		2	14		2		62	
	12		3	15		3		63	
	13		4	16		4		64	
	14		5	17		5		65	
	15		6	18		6		66	
*1	10	4	1	19	*1	10	12	1	67
	11		2	20		2		68	
	12		3	21		3		69	
	13		4	22		4		70	
	14		5	23		5		71	
	15		6	24		6		72	
*1	10	5	1	25	*1	10	13	1	73
	11		2	26		2		74	
	12		3	27		3		75	
	13		4	28		4		76	
	14		5	29		5		77	
	15		6	30		6		78	
*1	10	6	1	31	*1	10	14	1	79
	11		2	32		2		80	
	12		3	33		3		81	
	13		4	34		4		82	
	14		5	35		5		83	
	15		6	36		6		84	
*1	10	7	1	37	*1	10	15	1	85
	11		2	38		2		86	
	12		3	39		3		87	
	13		4	40		4		88	
	14		5	41		5		89	
	15		6	42		6		90	
*1	10	8	1	43	*1	10	16	1	91
	11		2	44		2		92	
	12		3	45		3		93	
	13		4	46		4		94	
	14		5	47		5		95	
	15		6	48		6		96	

*1) different possibilities of field device connections for further information see manuals of 91xx/xx-xx-xx

We reserve the right to make alterations to the technical data, weights, dimensions, designs and products available without notice.
The illustration cannot be considered binding.



pac- Carrier
9195/08A-EP1-05A5

- Signal types: 16 x AI, AO, DI,DO pac- Carrier for 8 modules, up to 16 signals
- All ISpac isolators can be mounted
- Customized system cable type 9195/C-007 to automation systems
- Redundant power supply with message contact and exchangeable fuses
- Horizontal or vertical installation
- Simple installation on DIN rail or mounting plate
- Many labeling possibilities
- Fast and secure installation of the isolators without tools
- Comfortable exchange of the isolators with secured ejector mechanism
- Installation possible in Zone 2, Zone 22 (non conductible dust) and Div. 2

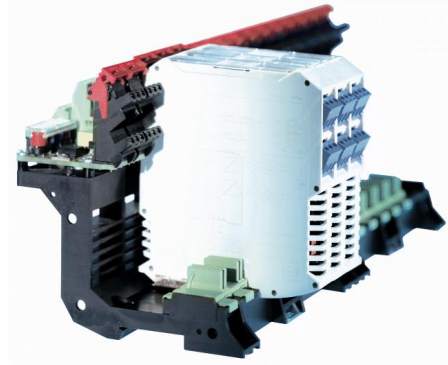

Comfortable and simple integration of the Ex i/I.S. isolators ISpac. Flexible wiring possibilities on the system side with screw terminals.

System overview

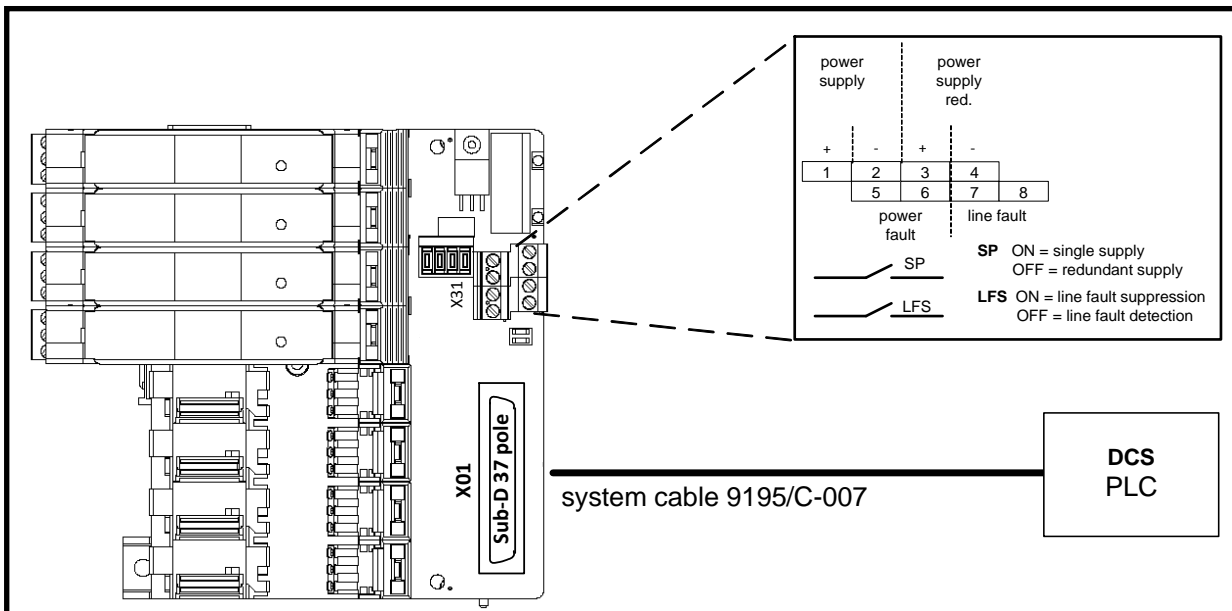

Selection table

Control system			pac- Carrier			
DCS manufacturer	DCS type	I/O-cards type	Slots	Channel	Stahl Cable type	Type
all	all	AI / AO/ DI / DO	8	16	9195/C-007	9195/08A-EP1-05A5

Technical data

Certificates	BVS 03 ATEX E213 X
Explosion protection	⊕ II 3 G Ex nA nC II T4
Installation	In Zone 2, Zone 22 (non conductible dust), Div. 2 and in the safe area
Power supply	(X31)
Nominal voltage U_N	24 V DC (19 V ... 31,2 V)
Redundant supply	yes, decoupled with diodes
Indication	2 LED green „PWR1“; „PWR2“
Fuse	2 x TR5; T 2,0 A; exchangeable, for primary and redundant supply
Polarity reversal protection	yes
Connection field devices	
Connection	at the terminals of the Ex/i.l.s. isolators (see “signal loops”)
Number of channels	16
Connection automation system	(X01)
Connection	plug Sub-D 37 pole for cable 9195/C-007 (open end cable)
Number of channels	up to 16
Error messaging	(X31)
Power supply failure PF	Contact (35 V / 100 mA), closed in good conditions
Line fault LF (of ISpac modules)	Contact (35 V / 100 mA), closed in good conditions
Setting switch „SP“	Power failure message suppressed for redundant supply (single supply)
Setting switch „LFS“	Line fault message suppressed
Ambient conditions	
Ambient temperature	max. - 20 °C ... + 70 °C (see specification of the Ex i/l.s. isolators)
Storage temperature	- 40 °C ... + 80 °C
Relative humidity (no condensation)	≤95 %
Mechanical data	
Weight	approx. 320 g
Mounting type	on DIN rail or mounting plate (4 x screw M6)
Mounting position	horizontal or vertical
Casing / Terminal protection class	IP 00 / IP 20
Casing material	PA 6.6
Fire protecting class (UL-94)	V0

Signal loops

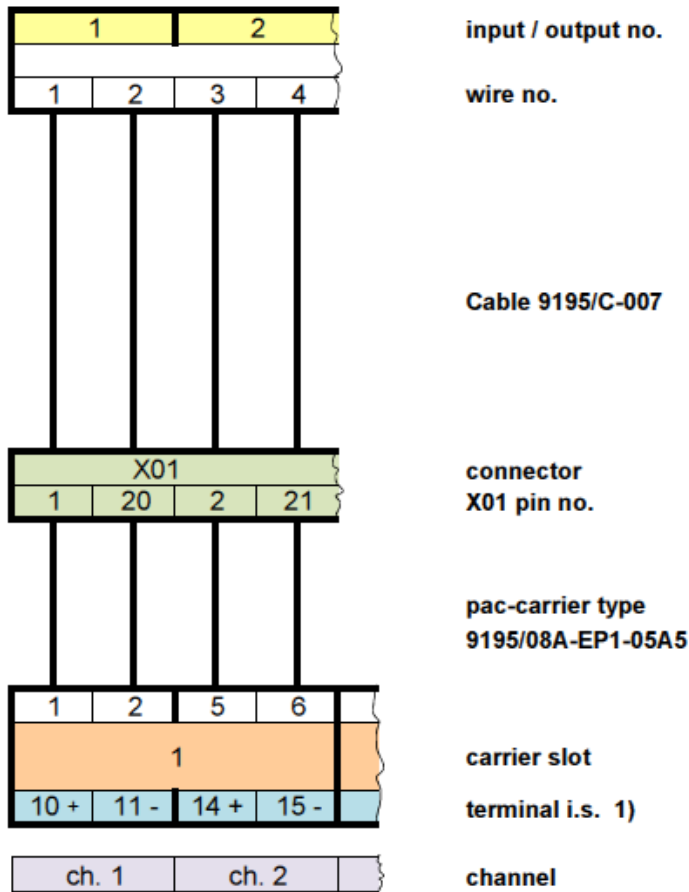

The diagrams below show typical applications. Please refer to the connection list to get the entire connection scheme. Basic technical parameters of the ISpac isolating repeaters can be found at the end of this document. The detailed specifications can be downloaded at: www.ispac.info.

typical input / output



1) For ISpac modules different possibilities of field device connections; for further informations see the specific manual

Accessories and Spare Parts

Designation	Illustration	Description	Order number
Non-Ex i Termination Module	 06314E00	The termination module is used to integrate non-Ex i field circuit into the system integration solution pac- Carrier type 9195. In such a way it enables a flexible mixture of Ex i and non-Ex i field circuits.	9191/20-00-50s
Fuse		Fuse T2,000A 250 V TR5. Minimum order is 10 pieces	111336
System cable		Customized system cable type 9195/C-007 with Sub-D 37 system cable 40 x 0,35 (AWG 24) grey	9195/C-007

Dimension drawings (all dimensions in mm) - subject to alterations

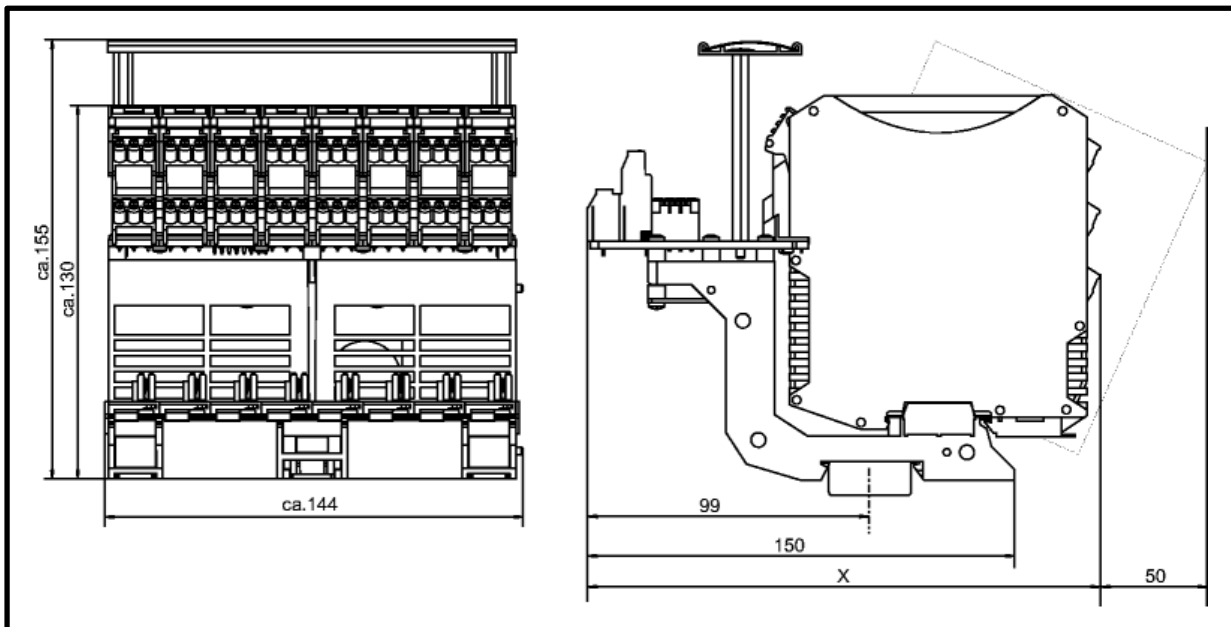

12472E00

	Dimension x
Screw terminals	176 mm
Cage clamp terminals	186 mm

Please note: In order to snap in the ISpac modules an extra space of approx. 50 mm is required. Please read the "ISpac engineering guideline" carefully before you start to engineer the enclosures with incorporated ISpac modules with or without pac- Carriers. The "ISpac engineering guideline" can be downloaded from: www.ispac.info.



Connection list

channel	terminal I.S. modules 1)		carrier slot	X01 (SubD37)		Cable 9195/C-007 open end		in-/ output no.
	pin no.	polarity		pin no.	polarity	color	no.	
1	10	+	1	1	+	White	1	1
	11	-		20	-	Brown	2	
2	14	+	1	2	+	Green	3	2
	15	-		21	-	Yellow	4	
3	10	+	2	3	+	Gray	5	3
	11	-		22	-	Pink	6	
4	14	+	2	4	+	Blue	7	4
	15	-		23	-	Red	8	
5	10	+	3	5	+	Black	9	5
	11	-		24	-	Purple	10	
6	14	+	3	6	+	gray-pink	11	6
	15	-		25	-	red-blue	12	
7	10	+	4	7	+	white-green	13	7
	11	-		26	-	brown-green	14	
8	14	+	4	8	+	white-yellow	15	8
	15	-		27	-	yellow-brown	16	
9	10	+	5	9	+	white-gray	17	9
	11	-		28	-	gray-brown	18	
10	14	+	5	10	+	white-pink	19	10
	15	-		29	-	pink-brown	20	
11	10	+	6	11	+	white-blue	21	11
	11	-		30	-	brown-blue	22	
12	14	+	6	12	+	white-red	23	12
	15	-		31	-	brown-red	24	
13	10	+	7	13	+	white-black	25	13
	11	-		32	-	brown-black	26	
14	14	+	7	14	+	gray-green	27	14
	15	-		33	-	yellow-gray	28	
15	10	+	8	15	+	pink-green	29	15
	11	-		34	-	yellow-pink	30	
16	14	+	8	16	+	green-blue	31	16
	15	-		35	-	yellow-blue	32	

*1) different possibilities of field device connections for further information see manuals of 91xx/xx-xx-xx

We reserve the right to make alterations to the technical data, weights, dimensions, designs and products available without notice.
The illustration cannot be considered binding



pac- Carrier
9195/16A-XX0-03B3

- Signal types: 32 x AI, AO, DI,DO
- pac- Carrier for 16 modules, up to 32 signals
- All ISpac isolators can be mounted
- Customized system cable type 9195/C-007 to automation systems
- Redundant power supply with message contact and exchangeable fuses
- Horizontal or vertical installation
- Simple installation on DIN rail or mounting plate
- Many labeling possibilities
- Fast and secure installation of the isolators without tools
- Comfortable exchange of the isolators with secured ejector mechanism
- Installation possible in Zone 2, Zone 22 (non conductible dust) and Div. 2

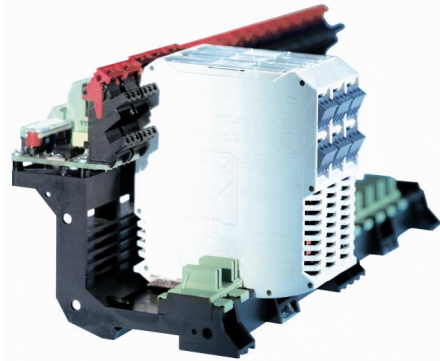

Comfortable and simple integration of the Ex i / I.S. isolators ISpac. Flexible wiring possibilities on the system side with screw terminals.

System overview

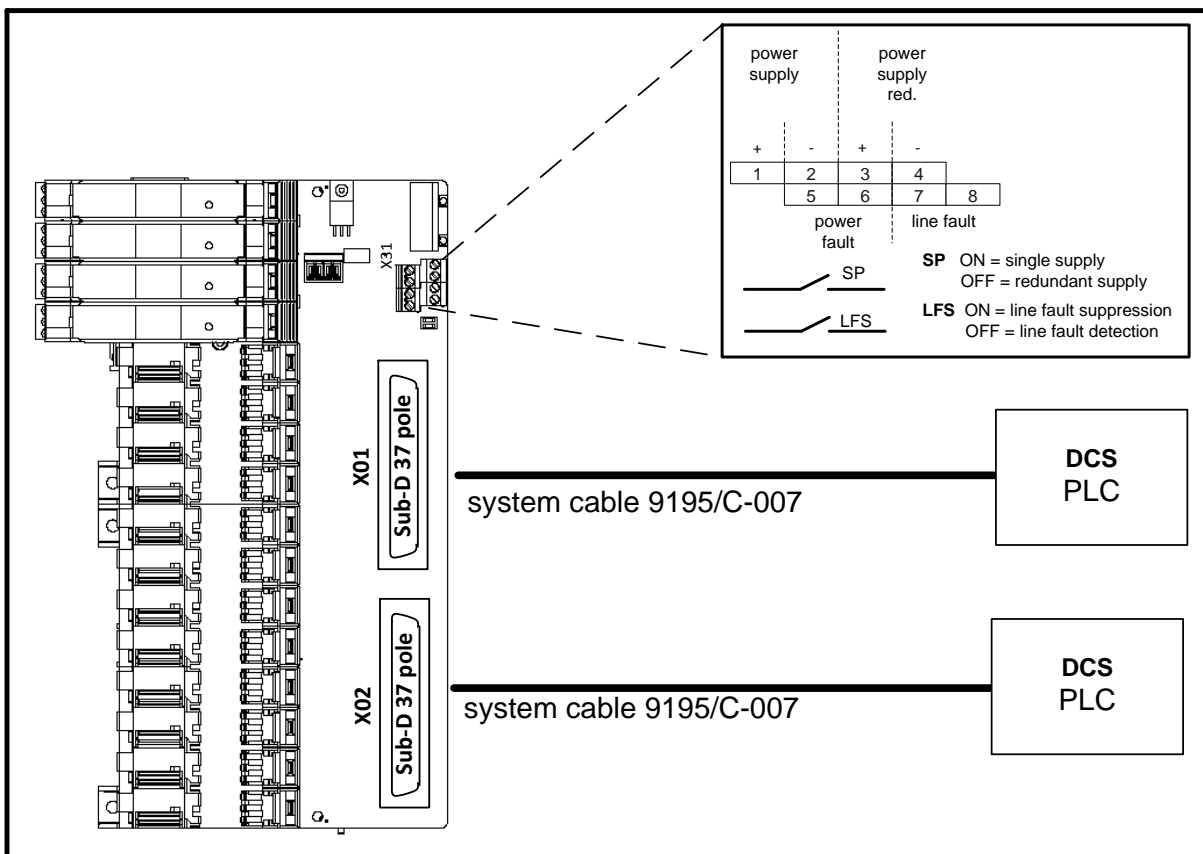

Selection table

Control system			pac- Carrier				
DCS manufacturer	DCS type	I/O-cards type	Slots	Channel	HART-MUX	Redundancy	Type
all	all	AI / AO/ DI / DO	16	32	no	no	9195/16A-XX0-03B3

Technical data

Certificates	BVS 03 ATEX E213 X
Explosion protection	⊕ II 3 G Ex nA nC II T4
Installation	In Zone 2, Zone 22 (non conductible dust), Div. 2 and in the safe area
Power supply	(X31)
Nominal voltage U _N	24 V DC (19 V ... 31,2 V)
Redundant supply	yes, decoupled with diodes
Indication	2 LED green „PWR1“; „PWR2“
Fuse	2 x TR5; T 2,0 A; exchangeable, for primary and redundant supply
Polarity reversal protection	yes
Connection field devices	
Connection	at the terminals of the Exi/I.S. isolators (see “signal loops”)
Number of channels	32
Connection automation system	(X01)
Connection	plug Sub-D 37 pole for 9195/C-007 cable with open end wires
Number of channels	up to 16
Connection automation system	(X02)
Connection	plug Sub-D 37 pole for 9195/C-007 cable with open end wires
Number of channels	up to 16
Error messaging	(X31)
Power supply failure PF	Contact (35 V / 100 mA), closed in good conditions
Line fault LF (of ISpac modules)	Contact (35 V / 100 mA), closed in good conditions
Setting switch „SP“	Power failure message suppressed for redundant supply (single supply)
Setting switch „LFS“	Line fault message suppressed
Ambient conditions	
Ambient temperature	max. - 20 °C ... + 70 °C (see specification of the Ex i/I.S. isolators)
Storage temperature	- 40 °C ... + 80 °C
Relative humidity (no condensation)	≤95 %
Mechanical data	
Weight	approx. 320 g
Mounting type	on DIN rail or mounting plate (4 x screw M6)
Mounting position	horizontal or vertical
Casing / Terminal protection class	IP 00 / IP 20
Casing material	PA 6.6
Fire protecting class (UL-94)	V0

Signal loops

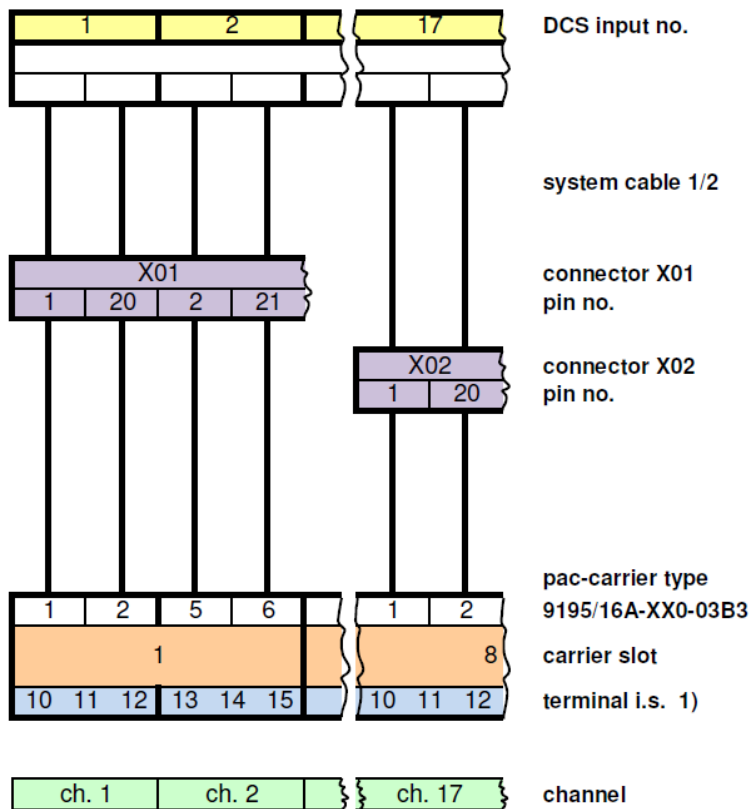

The diagrams below show typical applications. Please refer to the connection list to get the entire connection scheme. Basic technical parameters of the ISpac isolating repeaters can be found at the end of this document. The detailed specifications can be downloaded at: www.ispac.info.

typical input /output



1) different possibilities of field device connections; for further information see the specific manual

Accessories and Spare Parts

Designation	Illustration	Description	Order number
Non-Ex i Termination Module	 06314E00	The termination module is used to integrate non-Ex i field circuit into the system integration solution pac- Carrier type 9195. In such a way it enables a flexible mixture of Ex i and non-Ex i field circuits.	9191/20-00-50s
Fuse		Fuse T2,000A 250 V TR5. Minimum order is 10 pieces	111336
System cable		Customized system cable type 9195/C-007 with Sub-D 37 system cable 40 x 0,35 (AWG 24) grey	9195/C-007

Dimension drawings (all dimensions in mm) - subject to alterations

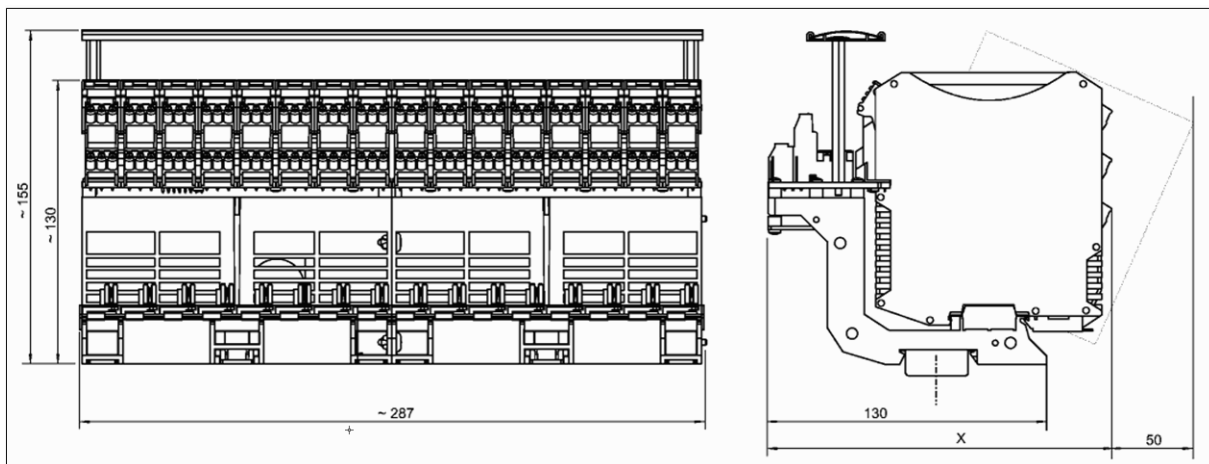

12472E00

	Dimension x
Screw terminals	176 mm
Cage clamp terminals	186 mm

Please note: In order to snap in the ISpac modules an extra space of approx. 50 mm is required. Please read the "ISpac engineering guideline" carefully before you start to engineer the enclosures with incorporated ISpac modules with or without pac-Carriers. The "ISpac engineering guideline" can be downloaded from: www.ispac.info.

Connection list

channel	terminal I.S. modules 1)			carrier slot	X01 (Sub-D37)		X02 (Sub-D37)		input pin no.	input no.
					(+) pin no.	(-) pin no.	(+) pin no.	(-) pin no.		
1	10	11	12	1	1	20				1
2	13	14	15			2	21			
3	10	11	12	2	3	22				3
4	13	14	15			4	23			
5	10	11	12	3	5	24				5
6	13	14	15			6	25			
7	10	11	12	4	7	26				7
8	13	14	15			8	27			
9	10	11	12	5	9	28				9
10	13	14	15			10	29			
11	10	11	12	6	11	30				11
12	13	14	15			12	31			
13	10	11	12	7	13	32				13
14	13	14	15			14	33			
15	10	11	12	8	15	34				15
16	13	14	15			16	35			
17	10	11	12	9			1	20		17
18	13	14	15					2	21	
19	10	11	12	10			3	22		19
20	13	14	15					4	23	
21	10	11	12	11			5	24		21
22	13	14	15					6	25	
23	10	11	12	12			7	26		23
24	13	14	15					8	27	
25	10	11	12	13			9	28		25
26	13	14	15					10	29	
27	10	11	12	14			11	30		27
28	13	14	15					12	31	
29	10	11	12	15			13	32		29
30	13	14	15					14	33	
31	10	11	12	16			15	34		31
32	13	14	15					16	35	

*1) different possibilities of field device connections for further information see manuals of 91xx/xx-xx-xx

We reserve the right to make alterations to the technical data, weights, dimensions, designs and products available without notice. The illustration cannot be considered binding

Notes:A small version of the STAHL logo, consisting of the word 'STAH' in a white, bold, sans-serif font inside a white octagonal border, set against a black square background.A larger version of the STAHL logo, consisting of the word 'STAH' in a white, bold, sans-serif font inside a white octagonal border, set against a blue square background.

R. STAHL Schaltgeräte GmbH
Am Bahnhof 30, D-74638 Waldenburg, Germany
Telefon +49 7942 943-0
Telefax +49 7942 943-4333
E-Mail: info.ex@stahl.de
Internet: <http://www.stahl.de>

S – EG / EP – 9195 – 8 – en – 08 / 2013