



Engineering Guideline

pac-Carriers Type 9195

for Yokogawa ProSafe-RS





Integrated solutions for Yokogawa

R. STAHL offers a wide range of customized solutions which allow the user to integrate field signals into the Yokogawa systems in an easy and cost effective manner. The solutions designed for Yokogawa cover the different ways of connecting field devices to process control systems nowadays. It ranges from carrier solutions with conventional I.S. isolators to the Remote I/O system and last but not least fieldbus solutions.

In addition to the products the R. STAHL Competence Centre provides the full range of services in consulting, engineering, commissioning and maintenance in order to contribute to Yokogawa's overall project business. We do not only regard ourselves as a manufacturer and supplier of components and systems, but also as a provider of comprehensive services.

Our engineers have many years of experience, from the engineering to the handling of smallest details, which is beneficial for you and your customer.

R. STAHL is able to manufacture completely equipped I.S. system cabinets for control room or field station. In addition to our approved R. STAHL standard components additional components from certified suppliers are used.

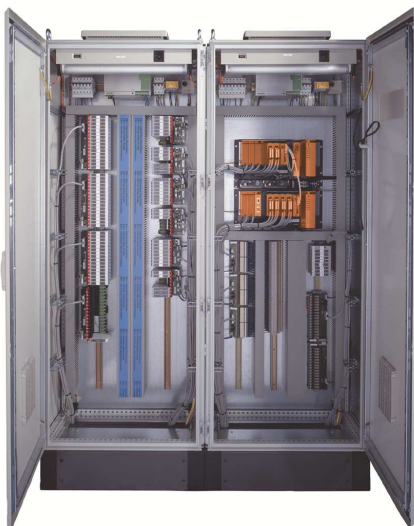

Example of a customer specific field station for a Yokogawa system

14994E00

Your benefits:

- Application oriented and cost optimized solutions for your customer project
- In depth consulting regarding automation solutions for hazardous areas
- Ready-made and pre-tested field stations facilitate the engineering and installation
- Experienced technical support

E-mail contact: support.automation@stahl.de



Integration of conventional process automation interfaces - pac- Carrier

The pac- Carrier reflects the intention of R. STAHL to provide state-of-the-art concepts tailored to the needs of Yokogawa for the field of process automation. It is designed to reduce the cost of installation by space saving compact design and simplified installation. The modules can be mounted without the need for a tool. The intrinsically safe signal is directly connected to the modules by means of three different types of detachable connectors - screw type, cage clamp type and insulating cutting type. The connection to the I/O module card is simply done by plugging the system cable into the socket of the pac- Carrier.

Interoperability with PRM / FieldMate

The integration into the Yokogawa's PRM can be easily achieved by the selection of an appropriate type of pac-Carrier along with the ISpac HART multiplexer type 9192. The pac-Carrier picks-up the HART signals and interfaces them to the HART multiplexer.

The PRM communicates with the multiplexer via RS 485 bus. A detailed description can be found in Yokogawa's GS-file for the PRM system.

The communication between HART Mux type 9192 and PRM / FieldMate can be established by means of HART Mux DTM. The DTM can be download free of charge on the ISpac Web page.

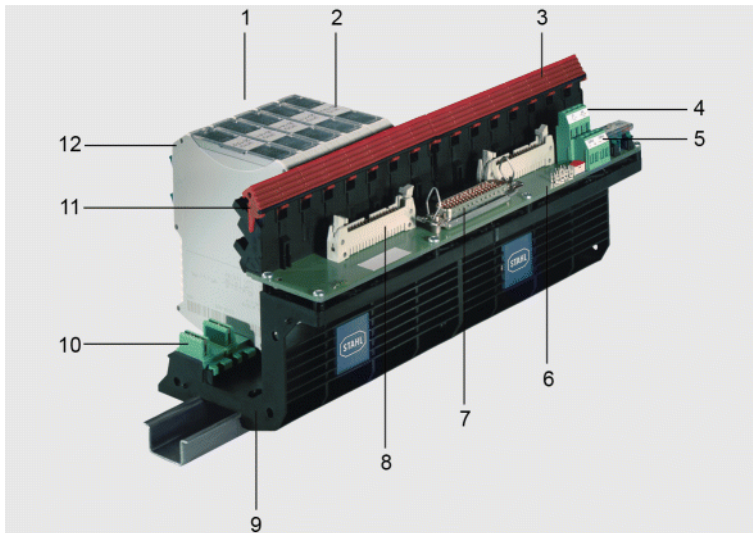

1. Detachable connectors
 - Screw terminals or
 - Cage clamp terminals or
 - Insulating cutting terminals
2. Labelling for module, slot and carrier
3. Ejector mechanism
4. Redundant and fused supply
5. Power supply failure and line fault signalling via relay
6. System card specific PCB
7. System cable plug
8. Signal duplication and/ or connection HART multiplexer
9. For DIN rail or mounting plate
10. Integrated pac bus for power supply and line-fault signalling
11. Secure snap-in mechanism, without tool
12. Single slot, any signal mixture

Your benefits

- Complete solutions for any kind of hazardous location world-wide
- Selection of the explosions protection method which fits best your needs – technically and economically
- Competent consulting and engineering
- In-house manufacturing ensures maximum flexibility and short delivery times
- Complete range of interface solutions – barriers, isolators, remote I/O, fieldbus, HMI and camera

HART-Multiplexer Type 9192

Basic function: multiplexer for HART field devices, 32 channels. The HART-Multiplexer type 9192 is used for digital connection of up to 32 HART-capable field devices, such as transmitters and regulating valves, to a PC. The PC communicates with the HART-Multiplexer via an RS 485 bus. The software PRM / FieldMate allows configuration and diagnostics of all connected HART-capable field devices, plus continuous documentation of the process variables and status.

Interconnection:

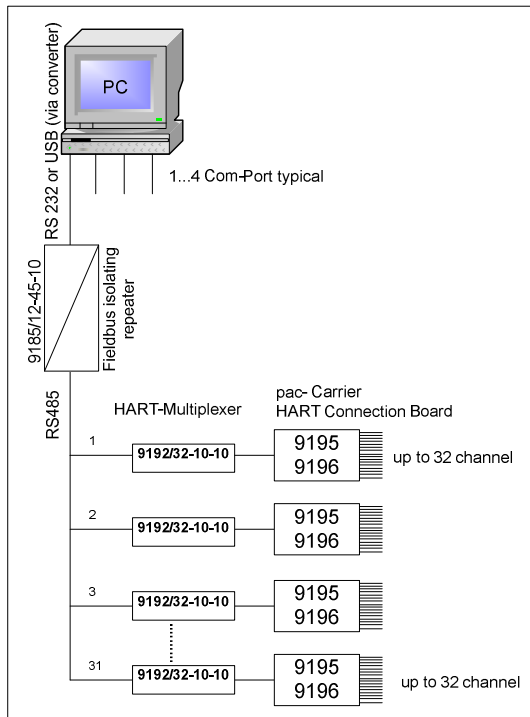

Accessories and Spare Parts

Designation	Description	Order number
Fieldbus isolating repeater	Adjustable baud rate (1.2kBit/s up to 1.5 MBit/s) Power supply 24 V AC/DC	9185/12-45-10s
pac-Carrier	8 slots, HART	9195/08H-...-...
	16 slots, HART	9195/16H-...-...
Connection board	for none Ex-applications, HART, 16 channels	9196/16H-XX0-...

Daisy chaining of several pac-Carriers to one HART-Multiplexer:

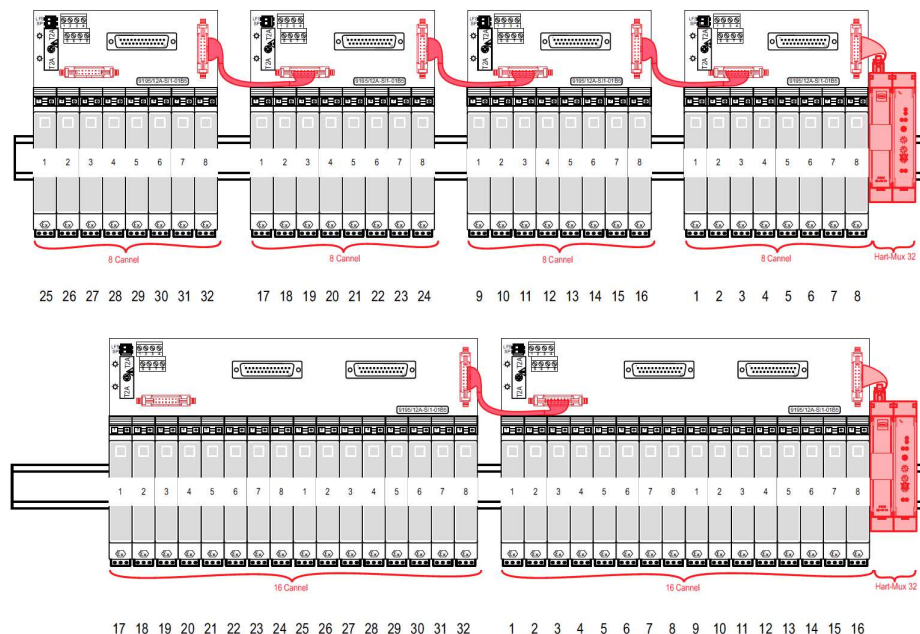

Mounting and dismounting the ISpac module in the pac- Carrier

- The black and green terminals must be removed before installation.
- Please remove additionally the cover for the second unused socket at single channel modules (apply a screwdriver at the lower edge).
- Set the ISpac modules in place as shown in pictures and completely tilt/snap into the pac- Carrier.
- Close the red latching lever using gentle pressure. The latching lever must engage completely.
- To dismount, use a screwdriver to open the latching mechanism as shown in the picture. The module is nudged out of the slot and can be removed.

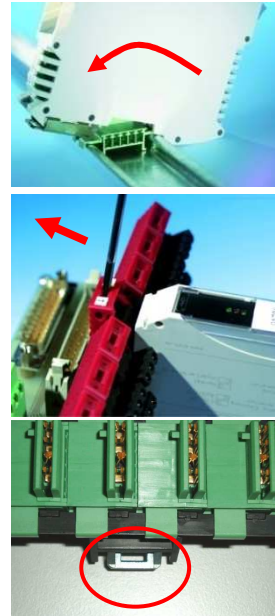

Mounting and dismounting the ISpac module in the pac- Carrier

- Mounting position: depends on the I.S. isolators that are used (see respective instructions)
- The pac-Carriers are snapped on DIN rails, versions NS35/15 or NS35/7.5.
- After installation please check that the locks are closed properly (see picture).
- It is also possible to install the pac-Carriers on mounting plates via screws.

Commissioning

1- Connection of power supply and failure message

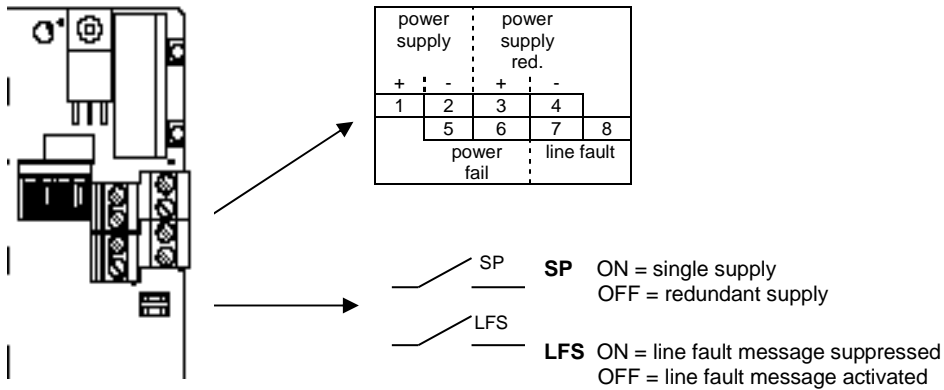

2- Settings

Line Fault Message LFS		Power supply SP	
suppressed	activated *)	single	redundant *)
OFF ON	OFF ON	OFF ON	OFF ON

*) Default factory settings

Changing settings via DIP switches during operation is also permitted in Zone 2 and Zone 22.



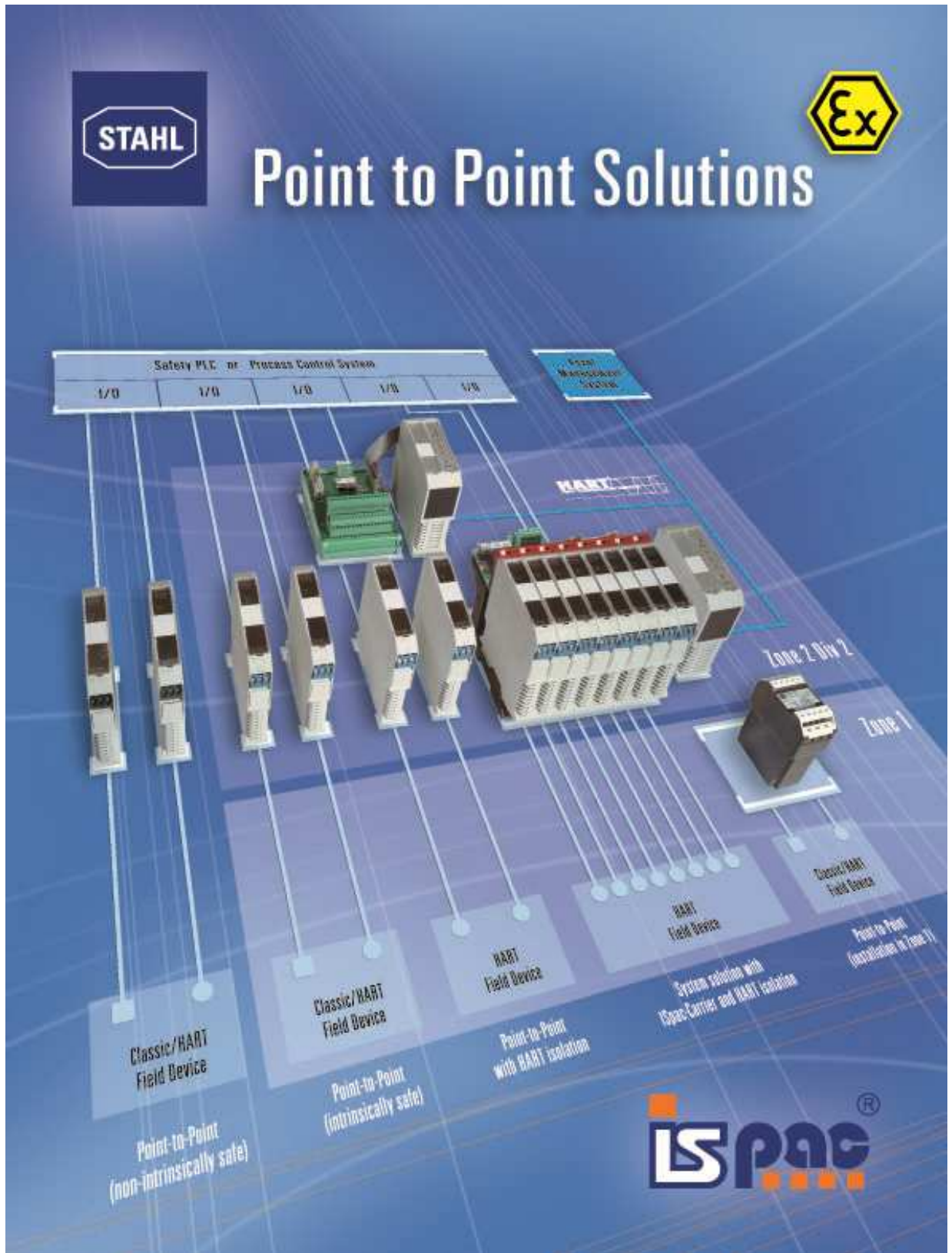

Contents

ProSafe-RS			pac-Carrier						
Signal type	I/O Module	Channel	Slots	Channel	HART MUX	Redundancy	pac-Carrier type	ISpac type	Page
DI	SDV 144	16	8	16	no	yes	9195/08A-YO3-03A2	9170/21-11-11 9170/21-14-11	9-14
	SDV 144	16	16	16	no	yes	9195/16A-YO3-03A2	9170/11-11-11 9170/11-14-11	15-20
DO	SDV 531	8	8	8	no	yes	9195/08A-YO3-04A2	9175/10-1*-11 9176/10-1*-00	21-25
	SDV 541	16	8	16	no	yes	9195/08A-YO3-03A2	9176/20-1*-00 9175/20-1*-11	9-14
	SDV 541	16	16	16	no	yes	9195/16A-YO3-03A2	9176/10-1*-00 9175/10-1*-11	15-20
AI	SAI 143	16	8	16	9192/32	yes	9195/08H-YO3-01V1	9160/23-11-1* 9163/23-11-10	27-31
	SAI 143	16	16	16	9192/32	yes	9195/16H-YO3-01V1	9160/13-11-1* 9182/10-51-13 9163/13-11-10	33-37
	SAV 144	16	8	16	9192/32	yes	9195/08H-YO3-02V1	9160/23-11-1* 9160/23-11-10	39-43
	SAV 144	16	16	16	9192/32	yes	9195/16H-YO3-02V1	9160/13-11-1* 9182/10-51-13 9163/13-11-10	45-49
AO	SAI 533	8	8	8	9192/32	yes	9195/08H-YO3-06V1	9165/16-11-11 9167/1*-11-00	51-55

**pac-Carrier
Type 9195/08A-YO3-03A2**

For Yokogawa / ProSafe-RS / SDV 144 / SDV 541

- Signal types: 16 x DI or 16 x DO
- pac-Carrier for 8 modules, up to 16 signals
- ISpac isolator DI 9170/21-11-11, 9170/21-14-11, 9176/20-1*-00 and 9175/20-1*-11 can be used
- Customized system cable type AKB331, YUC/YOC 50 to SIS
- Redundant power supply with fault signalization contact and exchangeable fuses
- Horizontal or vertical installation
- Simple installation on DIN rail or mounting plate
- Many labeling possibilities
- Fast and secure installation of the isolators without tools
- Comfortable exchange of the isolators with secured ejector mechanism
- Installation possible in Zone 2, Zone 22 (non conductible dust) and Div. 2

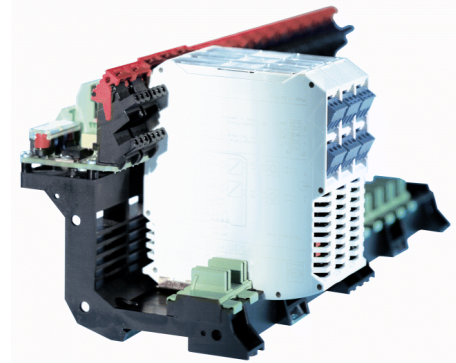

05179E0

Comfortable and simple integration of the I.S. isolators ISpac into Yokogawa / ProSafe-RS Safety instrumented systems via system specific connection boards and system cables.

System overview

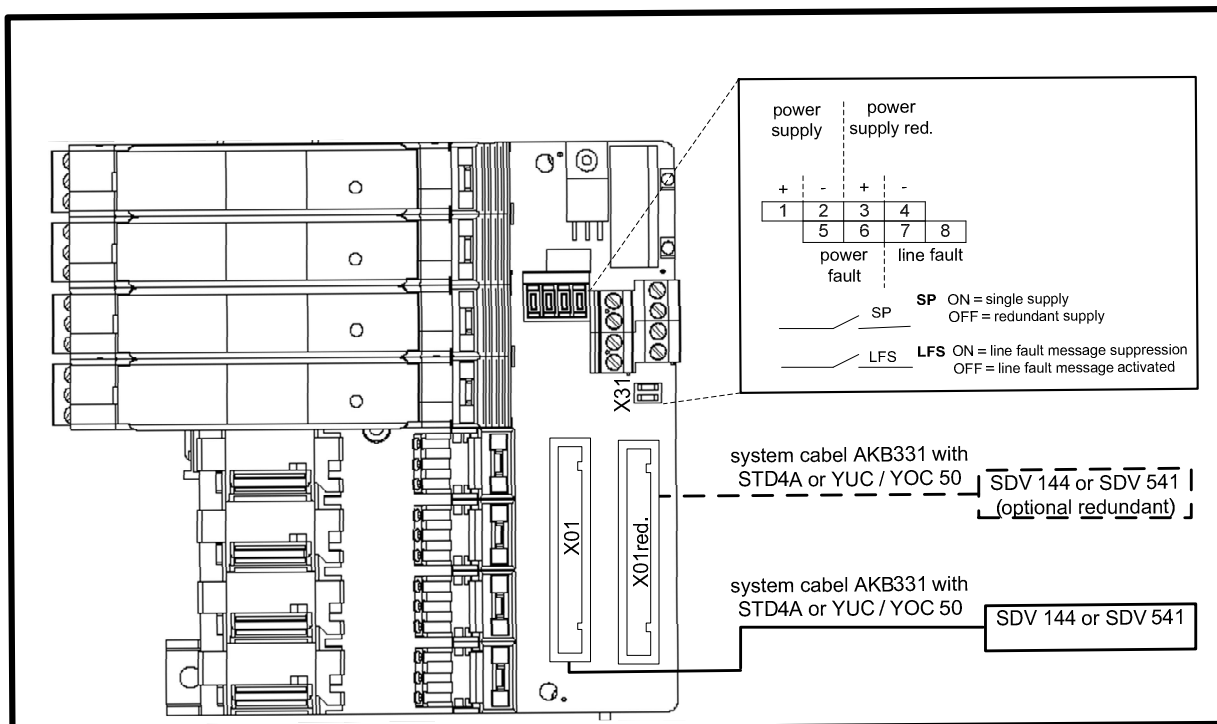

Selection table

Control system				pac-Carrier			
manufacturer	SIS type	I/O Module	Signal type	Slots	Channels	ISpac type	Type
Yokogawa	ProSafe-RS	SDV 144 SDV 541	16 x DI 16 x DO	8	16	9170/21-11-11 9170/21-14-11 9175/20-1*-11 9176/20-1*-00	9195/08A-YO3-03A2

Technical data

Certificates	BVS 03 ATEX E213 X
Explosion protection	⊕ II 3 G Ex nA nC II T4
Installation	In Zone 2, Zone 22 (non conductible dust), Div. 2 and in the safe area
Power supply	(X31)
Nominal voltage U_N	24 V DC (19 V ... 31,2 V)
Redundant supply	yes, decoupled with diodes
Indication	2 LED green „PWR1“, „PWR2“
Fuse	2 x TR5; T 2,0 A; exchangeable, for primary and redundant supply
Polarity reversal protection	yes
Connection field devices	
Connection	at the terminals of the I.S. isolators (specification see "signal loops")
Number of channels	16
Connection Safety instrumented system	(X01, X02)
Connection	2 x plug 50 pole for AKB331 or YUC/YOC 50 cable
Number of channels	up to 16 (additional 16 redundant channels available)
Error messaging	(X31)
Power supply failure PF	Contact (35 V / 100 mA), closed in good conditions
Line fault LF (of ISpac modules)	Contact (35 V / 100 mA), closed in good conditions
Setting switch „SP“	Power failure message suppressed for redundant supply (single supply)
Setting switch „LFS“	Line fault message suppressed
Ambient conditions	
Ambient temperature	max. - 20 °C ... + 70 °C (see specification of the I.S. isolators)
Storage temperature	- 40 °C ... + 80 °C
Relative humidity (no condensation)	≤ 95 %
Mechanical data	
Weight	approx. 320 g
Mounting type	on DIN rail (NS35 / 15, NS35 / 7.5) or mounting plate (4 x screw M6)
Mounting position	horizontal or vertical
Casing / Terminal protection class	IP 00 / IP 20
Casing material	PA 6.6
Fire protecting class (UL-94)	V0

Signal loops

The diagrams below show typical applications. Please refer to the connection list to get the entire connection scheme. Basic technical parameters of the ISpac isolating repeaters can be found at the end of this document. The detailed specifications can be downloaded at: www.ispac.info.

Switching repeater (DI)

for NAMUR proximity switches and contacts
- relay output

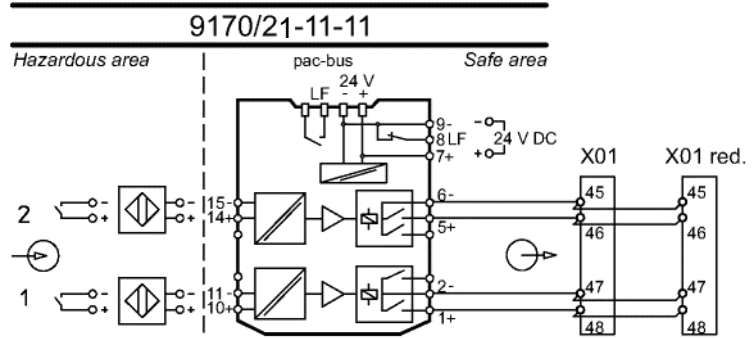

Switching repeater (DI)

for NAMUR proximity switches and contacts
- electronic output

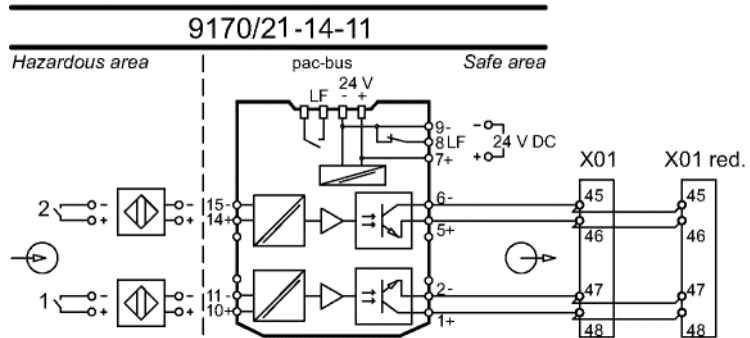

Digital Output (DO)

for solenoid valves and indicators

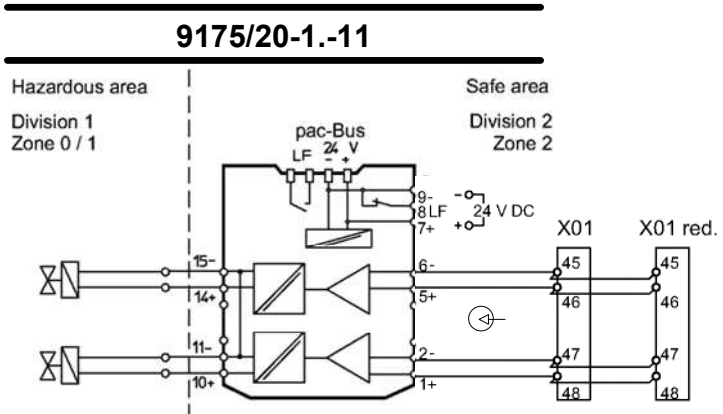

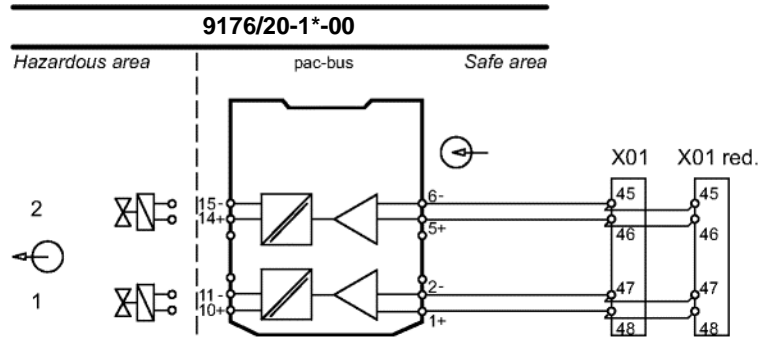

Digital Output (DO)
for solenoid valves and indicators



¹⁾ The Detec Disconnection und the Pulse tests function are disabled on ProSafe-RS



Accessories and Spare Parts

Designation	Illustration	Description	Order number
Non-Ex i Termination Module	 06314E00	The termination module is used to integrate non-Ex i field circuit into the system integration solution pac-Carrier type 9195. In such a way it enables a flexible mixture of Ex i and non-Ex i field circuits.	9191/20-00-50s
Fuse		Fuse T2,000A 250 V TR5. Minimum order is 10 pieces	111336

Dimension drawings (all dimensions in mm) - subject to alterations

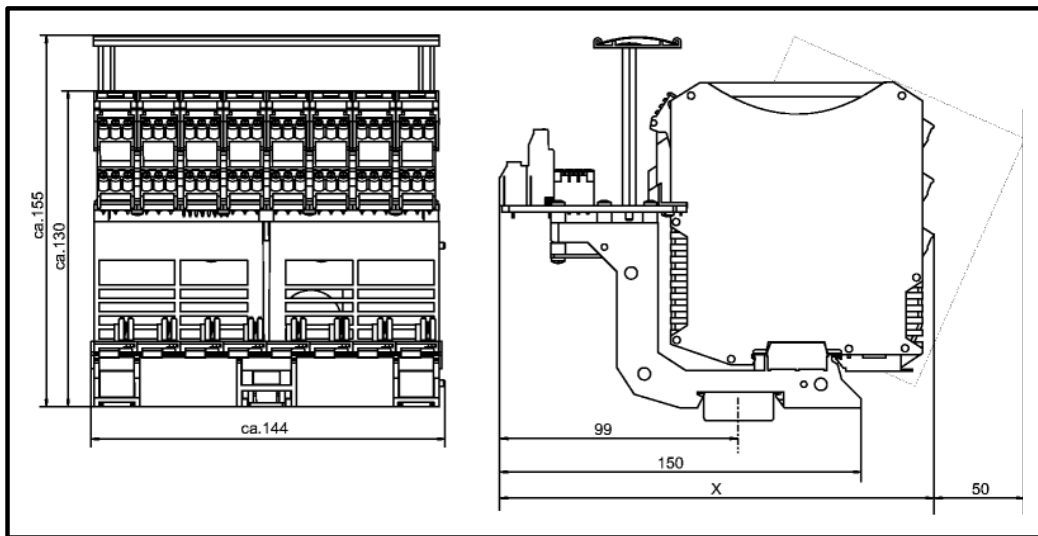

05177E00

	Dimension x
Screw terminals	176 mm
Cage clamp terminals	186 mm

Please note: In order to snap in the ISpac modules an extra space of approx. 50 mm is required. Please read the "ISpac Cabinet installation guide" carefully before you start to engineer the enclosures with incorporated ISpac modules with or without pac-Carriers. The "ISpac Cabinet installation guide" can be downloaded from: www.ispac.info.



Connection list

terminal I.S. *)		channel	carrier slot	in-/output no.	pin X01 (STD4A + AKB331)		pin X01 red. (STD4A + AKB331)	
10	+	1	1	1	+	48	+	48
11	-				-	47	-	47
14	+	2		2	+	46	+	46
15	-				-	45	-	45
10	+	3	2	3	+	44	+	44
11	-				-	43	-	43
14	+	4		4	+	42	+	42
15	-				-	41	-	41
10	+	5	3	5	+	40	+	40
11	-				-	39	-	39
14	+	6		6	+	38	+	38
15	-				-	37	-	37
10	+	7	4	7	+	36	+	36
11	-				-	35	-	35
14	+	8		8	+	34	+	34
15	-				-	33	-	33
10	+	9	5	9	+	32	+	32
11	-				-	31	-	31
14	+	10		10	+	30	+	30
15	-				-	29	-	29
10	+	11	6	11	+	28	+	28
11	-				-	27	-	27
14	+	12		12	+	26	+	26
15	-				-	25	-	25
10	+	13	7	13	+	24	+	24
11	-				-	23	-	23
14	+	14		14	+	22	+	22
15	-				-	21	-	21
10	+	15	8	15	+	20	+	20
11	-				-	19	-	19
14	+	16		16	+	18	+	18
15	-				-	17	-	17

) Different possibilities of field device connections; for further information see manual of DI 9170/21-11-11, 9170/21-14-11, 9176/20-1-00 or 9175/20-1*-11

**pac-Carrier
Type 9195/16A-YO3-03A2**

For Yokogawa / ProSafe-RS / SDV 144 / SDV 541

- Signal types: 16 x DI or 16 x DO
- pac-Carrier for 8 modules, up to 16 signals
- ISpac isolator DI 9170/11-11-11, 9170/11-14-11 and DO 9175/10-1*-11, 9176/10-1*-00 can be used
- Customized system cable type AKB331, YUC/YOC 50 to SIS
- Redundant power supply with fault signalization contact and exchangeable fuses
- Horizontal or vertical installation
- Simple installation on DIN rail or mounting plate
- Many labeling possibilities
- Fast and secure installation of the isolators without tools
- Comfortable exchange of the isolators with secured ejector mechanism
- Installation possible in Zone 2, Zone 22 (non conductible dust) and Div. 2

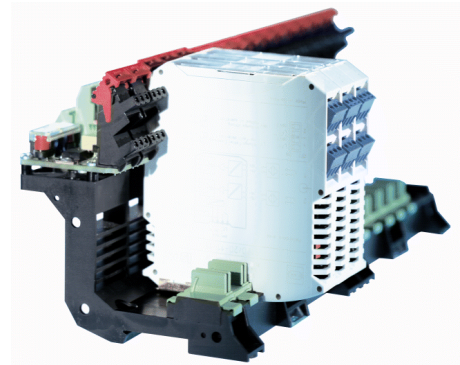

05179E0

Comfortable and simple integration of the I.S. isolators ISpac into Yokogawa / ProSafe-RS Safety instrumented systems via system specific connection boards and system cables.

System overview

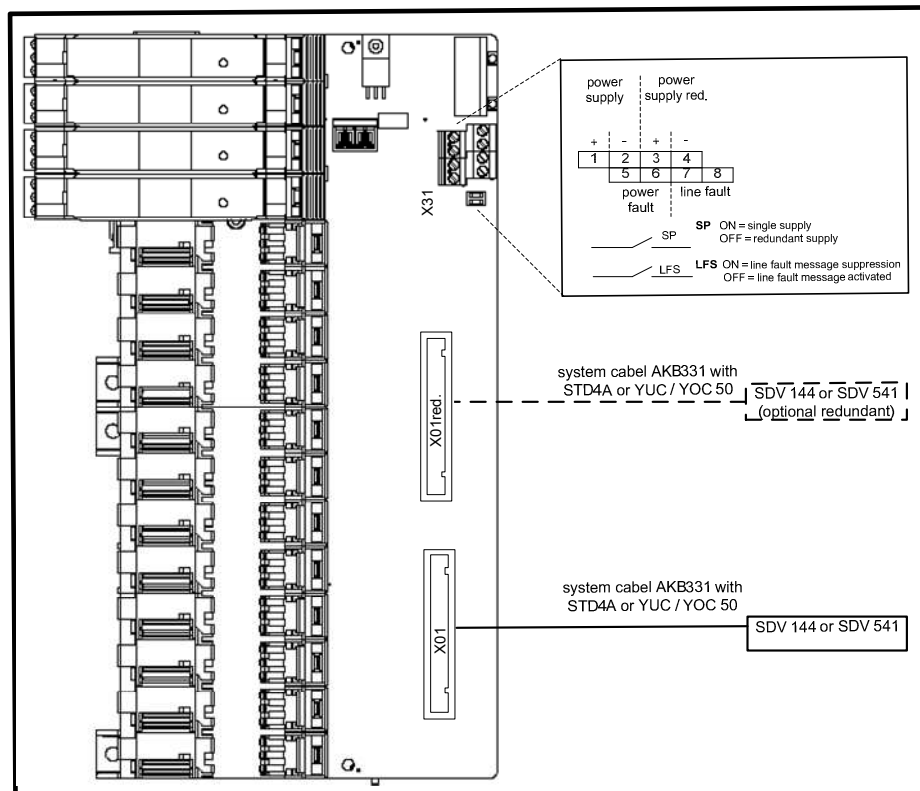

Selection table

Control system				pac-Carrier			
Manufacturer	SIS type	I/O Module	Signal type	Slots	Channels	ISpac type	Type
Yokogawa	ProSafe-RS	SDV 144 SDV 541	16 x DI 16 x DO	16	16	9170/11-11-11 9170/11-14-11 9175/10-1*-11 9176/10-1*-00	9195/16A-YO3-03A2

Technical data

Certificates	BVS 03 ATEX E213 X
Explosion protection	⊕ II 3 G Ex nA nC II T4
Installation	In Zone 2, Zone 22 (non conductible dust), Div. 2 and in the safe area
Power supply	(X31)
Nominal voltage U_N	24 V DC (19 V ... 31,2 V)
Redundant supply	yes, decoupled with diodes
Indication	2 LED green „PWR1“, „PWR2“
Fuse	2 x TR5; T 2,0 A; exchangeable, for primary and redundant supply
Polarity reversal protection	yes
Connection field devices	
Connection	at the terminals of the I.S. isolators (specification see "signal loops")
Number of channels	16
Connection Safety instrumented system	(X01, X02)
Connection	2 x plug 50 pole for AKB331 or YUC/YOC 50 cable
Number of channels	up to 16 (additional 16 redundant channels available)
Error messaging	(X31)
Power supply failure PF	Contact (35 V / 100 mA), closed in good conditions
Line fault LF (of ISpac modules)	Contact (35 V / 100 mA), closed in good conditions
Setting switch „SP“	Power failure message suppressed for redundant supply (single supply)
Setting switch „LFS“	Line fault message suppressed
Ambient conditions	
Ambient temperature	max. - 20 °C ... + 70 °C (see specification of the I.S. isolators)
Storage temperature	- 40 °C ... + 80 °C
Relative humidity (no condensation)	≤ 95 %
Mechanical data	
Weight	approx. 320 g
Mounting type	on DIN rail (NS35 / 15, NS35 / 7.5) or mounting plate (4 x screw M6)
Mounting position	horizontal or vertical
Casing / Terminal protection class	IP 00 / IP 20
Casing material	PA 6.6
Fire protecting class (UL-94)	V0

Signal loops

The diagrams below show typical applications. Please refer to the connection list to get the entire connection scheme. Basic technical parameters of the ISpac isolating repeaters can be found at the end of this document. The detailed specifications can be downloaded at: www.ispac.info.

Switching repeater (DI)

for NAMUR proximity switches and contacts
- relay output

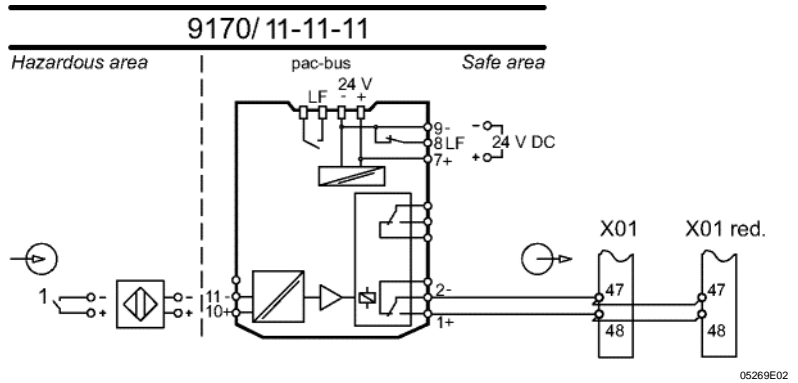

Switching repeater (DI)

for NAMUR proximity switches and contacts
- electronic output

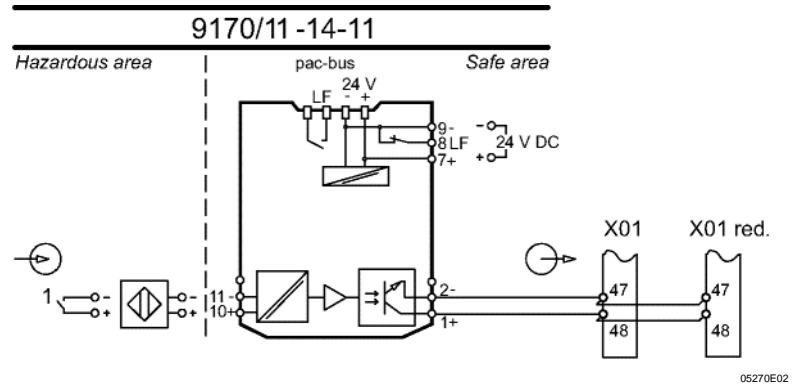

Digital Output (DO)

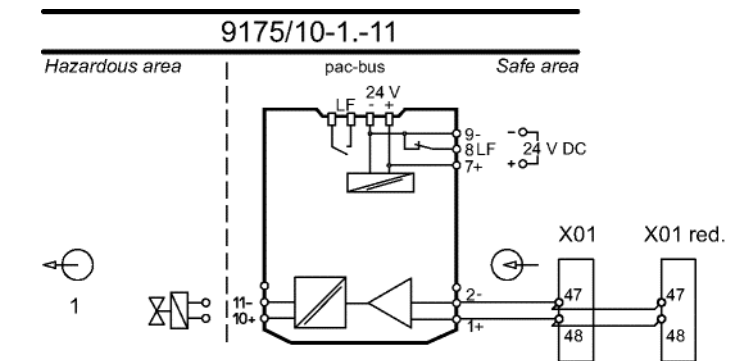

for solenoid valves and indicators

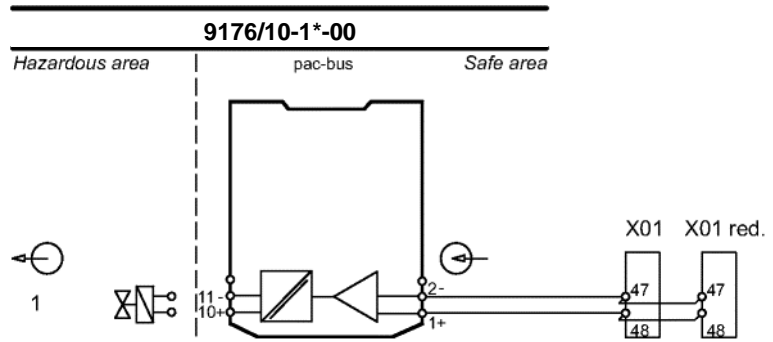

Digital Output (DO)
for solenoid valves and indicators



1) The Detec Disconnection und the Pulse tests function are disabled on ProSafe-RS 05236E02

Accessories and Spare Parts			
Designation	Illustration	Description	Order number
Non-Ex i Termination Module	 06314E00	The termination module is used to integrate non-Ex i field circuit into the system integration solution pac-Carrier type 9195. In such a way it enables a flexible mixture of Ex i and non-Ex i field circuits.	9191/20-00-50s
Fuse		Fuse T2,000A 250 V TR5. Minimum order is 10 pieces	111336

Dimension drawings (all dimensions in mm) - subject to alterations

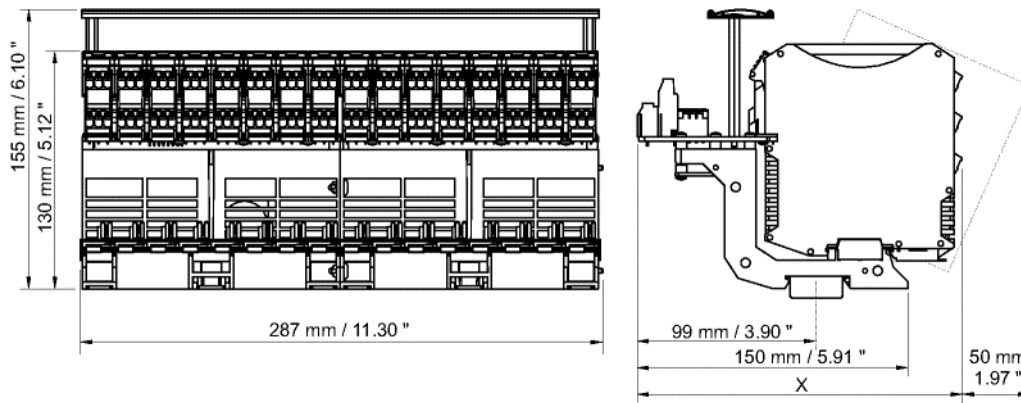

05178E00

	Dimension x
Screw terminals	176 mm
Cage clamp terminals	186 mm

Please note: In order to snap in the ISpac modules an extra space of approx. 50 mm is required. Please read the "ISpac Cabinet installation guide" carefully before you start to engineer the enclosures with incorporated ISpac modules with or without pac-Carriers. The "ISpac Cabinet installation guide" can be downloaded from: www.ispac.info.



Connection list

terminal I.S. *)		channel	carrier slot	in-/output no.	pin X01 (STD4A + AKB331)		pin X01 red. (STD4A + AKB331)	
10	+	1	1	1	+	48	+	48
11	-				-	47	-	47
10	+	2	2	2	+	46	+	46
11	-				-	45	-	45
10	+	3	3	3	+	44	+	44
11	-				-	43	-	43
10	+	4	4	4	+	42	+	42
11	-				-	41	-	41
10	+	5	5	5	+	40	+	40
11	-				-	39	-	39
10	+	6	6	6	+	38	+	38
11	-				-	37	-	37
10	+	7	7	7	+	36	+	36
11	-				-	35	-	35
10	+	8	8	8	+	34	+	34
11	-				-	33	-	33
10	+	9	9	9	+	32	+	32
11	-				-	31	-	31
10	+	10	10	10	+	30	+	30
11	-				-	29	-	29
10	+	11	11	11	+	28	+	28
11	-				-	27	-	27
10	+	12	12	12	+	26	+	26
11	-				-	25	-	25
10	+	13	13	13	+	24	+	24
11	-				-	23	-	23
10	+	14	14	14	+	22	+	22
11	-				-	21	-	21
10	+	15	15	15	+	20	+	20
11	-				-	19	-	19
10	+	16	16	16	+	18	+	18
11	-				-	17	-	17

*) Different possibilities of field device connections; for further information see manual of 9170/11-11-11
9170/11-14-11, 9176/10-1*-00, 9175/10-1*-11.

**pac-Carrier
Type 9195/08A-YO3-04A2**

For Yokogawa / ProSafe-RS / SDV 531

- Signal types: 8 x DO
- pac-Carrier for 8 modules, up to 8 signals
- ISpac isolator DO 9175/10-1*-11 or 9176/10-1*-00 can be used
- Customized system cable type AKB331 or YUC/YOC 50 to SIS
- Redundant power supply with fault signalization contact and exchangeable fuses
- Horizontal or vertical installation
- Simple installation on DIN rail or mounting plate
- Many labeling possibilities
- Fast and secure installation of the isolators without tools
- Comfortable exchange of the isolators with secured ejector mechanism
- Installation possible in Zone 2, Zone 22 (non conductible dust) and Div. 2

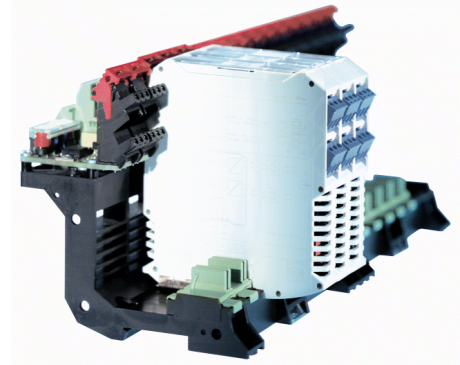

05179E0

Comfortable and simple integration of the I.S. isolators ISpac into Yokogawa / ProSafe-RS Safety instrumented systems via system specific connection boards and system cables.

System overview

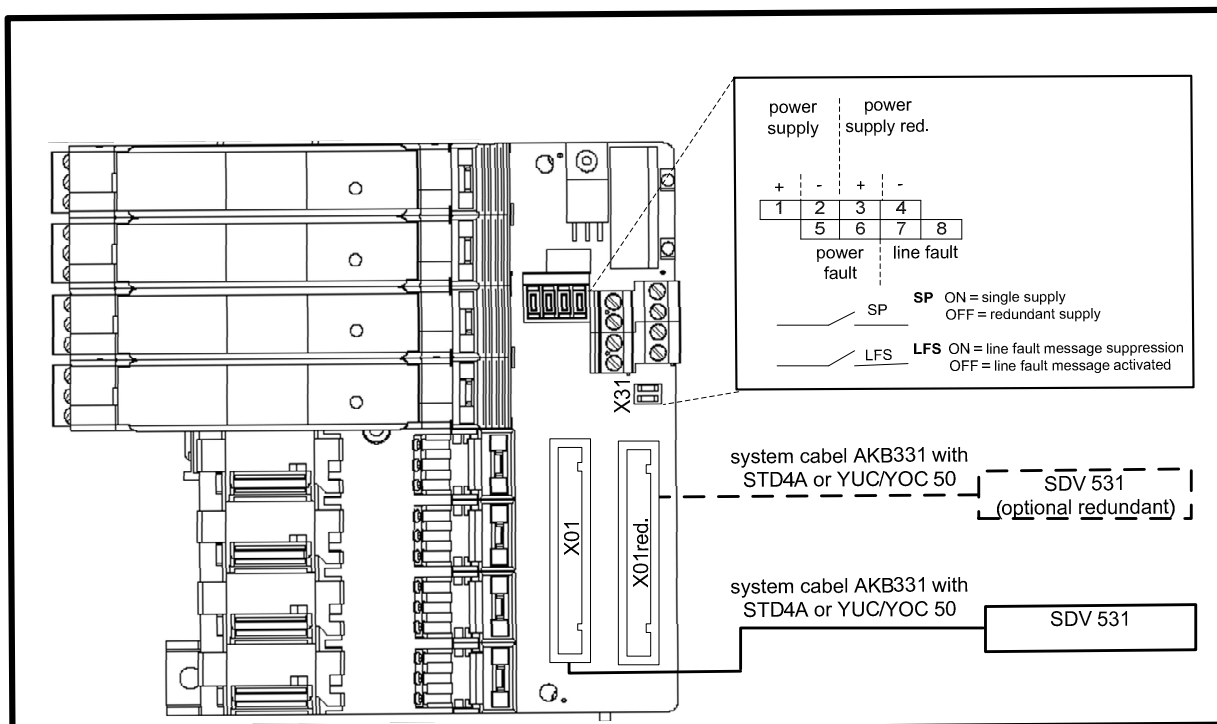

Selection table

Control system				pac-Carrier			
manufacturer	SIS type	I/O Module	Signal type	Slots	Channels	ISpac type	Type
Yokogawa	ProSafe-RS	SDV 531	8 x DO	8	8	9175/10-1*-11 9176/10-1*-00	9195/08A-YO3-04A2

Technical data

Certificates	BVS 03 ATEX E213 X
Explosion protection	⊕ II 3 G Ex nA nC II T4
Installation	In Zone 2, Zone 22 (non conductible dust), Div. 2 and in the safe area
Power supply	(X31)
Nominal voltage U_N	24 V DC (19 V ... 31,2 V)
Redundant supply	yes, decoupled with diodes
Indication	2 LED green „PWR1“; „PWR2“
Fuse	2 x TR5; T 2,0 A; exchangeable, for primary and redundant supply
Polarity reversal protection	yes
Connection field devices	
Connection	at the terminals of the I.S. isolators (specification see "signal loops")
Number of channels	8
Connection Safety instrumented system	(X01, X02)
Connection	2 x plug 50 pole for KS1 or YUC/YOC 50 cable
Number of channels	up to 8 (additional 8 redundant channels available)
Error messaging	(X31)
Power supply failure PF	Contact (35 V / 100 mA), closed in good conditions
Line fault LF (of ISpac modules)	Contact (35 V / 100 mA), closed in good conditions
Setting switch „SP“	Power failure message suppressed for redundant supply (single supply)
Setting switch „LFS“	Line fault message suppressed
Ambient conditions	
Ambient temperature	max. - 20 °C ... + 70 °C (see specification of the I.S. isolators)
Storage temperature	- 40 °C ... + 80 °C
Relative humidity (no condensation)	≤ 95 %
Mechanical data	
Weight	approx. 320 g
Mounting type	on DIN rail (NS35 / 15, NS35 / 7.5) or mounting plate (4 x screw M6)
Mounting position	horizontal or vertical
Casing / Terminal protection class	IP 00 / IP 20
Casing material	PA 6.6
Fire protecting class (UL-94)	V0

Signal loops

The diagrams below show typical applications. Please refer to the connection list to get the entire connection scheme. Basic technical parameters of the ISpac isolating repeaters can be found at the end of this document. The detailed specifications can be downloaded at: www.ispac.info.

Digital Output (DO)

for solenoid valves and indicators

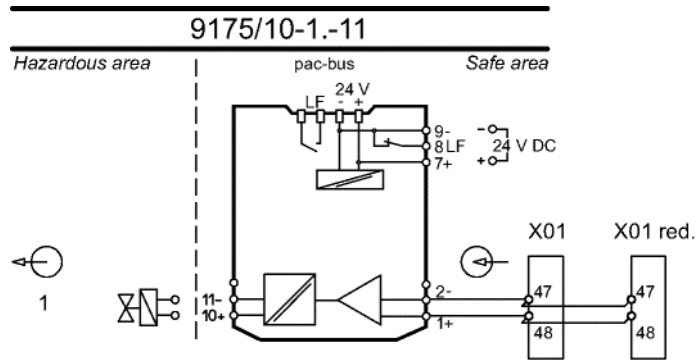

05228E02

Digital Output (DO)

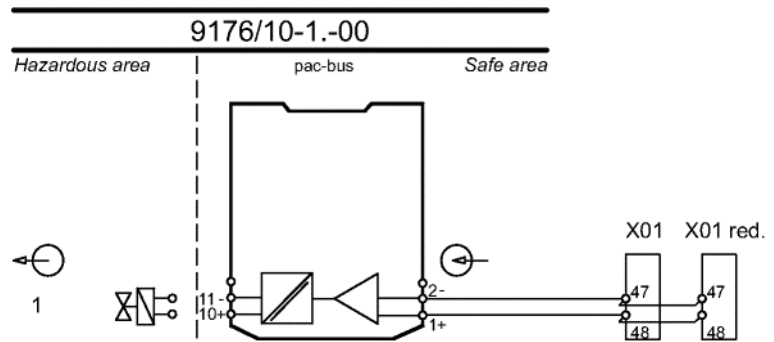

for solenoid valves and indicators



05236E02



Accessories and Spare Parts

Designation	Illustration	Description	Order number
Non-Ex i Termination Module	 06314E00	The termination module is used to integrate non-Ex i field circuit into the system integration solution pac-Carrier type 9195. In such a way it enables a flexible mixture of Ex i and non-Ex i field circuits.	9191/20-00-50s
Fuse		Fuse T2,000A 250 V TR5. Minimum order is 10 pieces	111336

Dimension drawings (all dimensions in mm) - subject to alterations

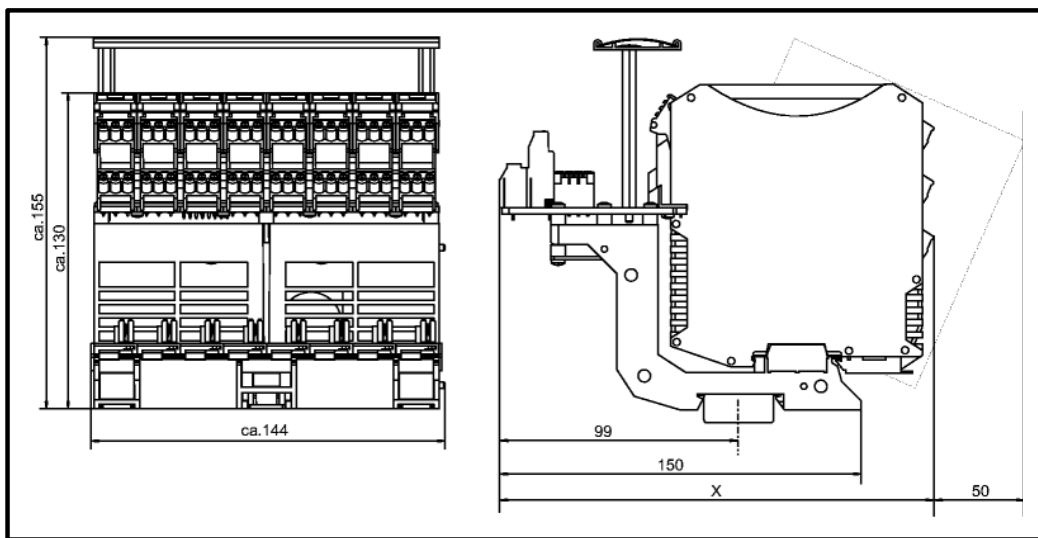

05177E00



	Dimension x
Screw terminals	176 mm
Cage clamp terminals	186 mm

Please note: In order to snap in the ISpac modules an extra space of approx. 50 mm is required. Please read the "ISpac Cabinet installation guide" carefully before you start to engineer the enclosures with incorporated ISpac modules with or without pac-Carriers. The "ISpac Cabinet installation guide" can be downloaded from: www.ispac.info.

Connection list

terminal I.S. *)		channel	carrier slot	input no.	pin X01 (STD4A + AKB331)		pin X01 red. (STD4A + AKB331)	
10	+	1	1	1	+	48	+	48
11	-				-	47	-	47
10	+	2	2	2	+	46	+	46
11	-				-	45	-	45
10	+	3	3	3	+	44	+	44
11	-				-	43	-	43
10	+	4	4	4	+	42	+	42
11	-				-	41	-	41
10	+	5	5	5	+	40	+	40
11	-				-	39	-	39
10	+	6	6	6	+	38	+	38
11	-				-	37	-	37
10	+	7	7	7	+	36	+	36
11	-				-	35	-	35
10	+	8	8	8	+	34	+	34
11	-				-	33	-	33

) Different possibilities of field device connections; for further information see manual of 9175/10-1-11 or 9176/10-1*-00.



**pac-Carrier
Type 9195/08H-YO3-01V1**

For Yokogawa / ProSafe-RS / SAI 143

- Signal types: 16 x AI
- pac-Carrier for 8 modules, up to 16 signals
- ISpac isolator AI 9160/23-11-1* and 9163/23-11-10 can be used
- Connection to HART-management systems
- Customized system cable type KS1 or YUC 40 to SIS
- Redundant power supply with fault signalization contact and exchangeable fuses
- Horizontal or vertical installation
- Simple installation on DIN rail or mounting plate
- Many labeling possibilities
- Fast and secure installation of the isolators without tools
- Comfortable exchange of the isolators with secured ejector mechanism
- Installation possible in Zone 2, Zone 22 (non conductible dust) and Div. 2

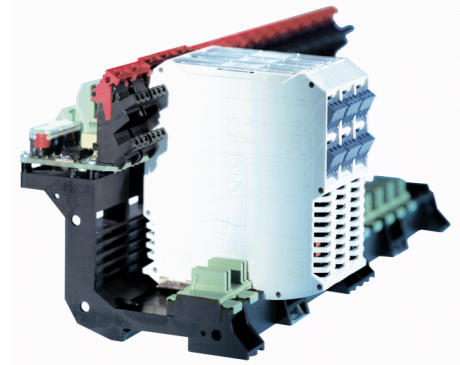

05179E0

Comfortable and simple integration of the I.S. isolators ISpac into Yokogawa / ProSafe-RS Safety instrumented systems via system specific connection boards and system cables.

System overview

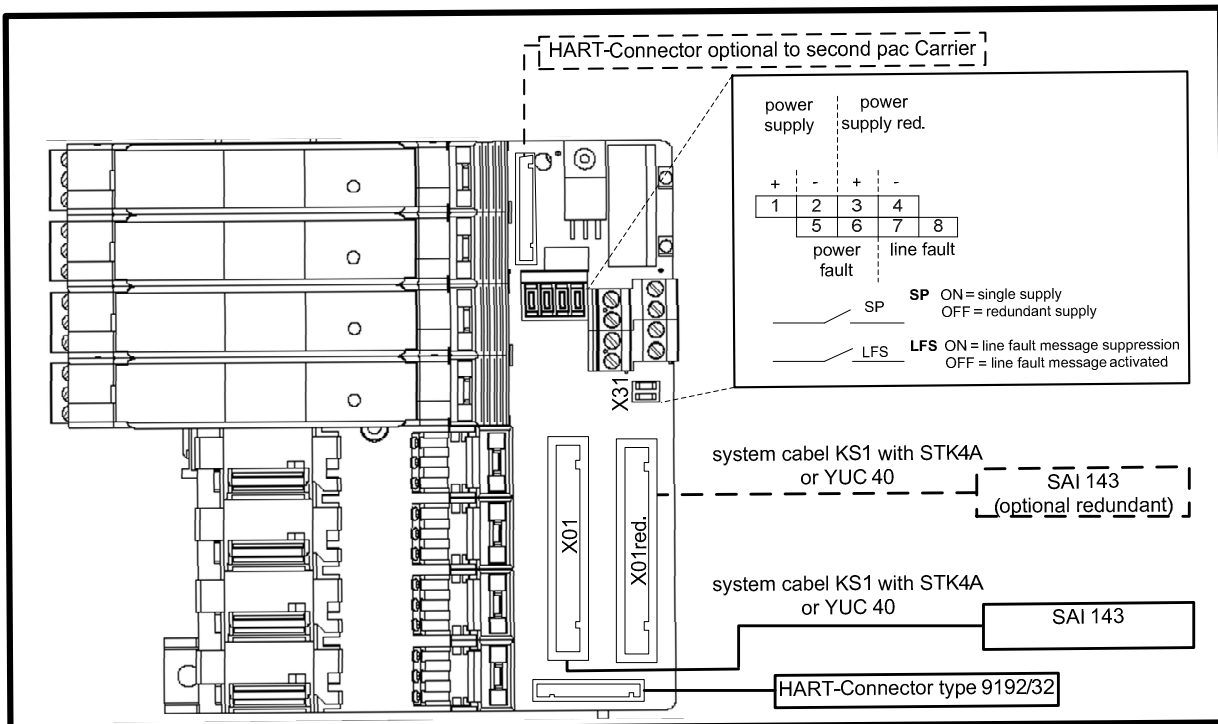

Selection table

Control system				pac-Carrier				
manufacturer	SIS type	I/O Module	Signal type	Slots	HART-MUX	Channels	ISpac type	Type
Yokogawa	ProSafe-RS	SAI 143	16 x AI	8	9192/32	16	9160/23-11-1* 9163/23-11-10	9195/08H-YO3-01V1

Technical data

Certificates	BVS 03 ATEX E213 X
Explosion protection	⊕ II 3 G Ex nA nC II T4
Installation	In Zone 2, Zone 22 (non conductible dust), Div. 2 and in the safe area
Power supply	(X31)
Nominal voltage U _N	24 V DC (19 V ... 31,2 V)
Redundant supply	yes, decoupled with diodes
Indication	2 LED green „PWR1“; „PWR2“
Fuse	2 x TR5; T 2,0 A; exchangeable, for primary and redundant supply
Polarity reversal protection	yes
Connection field devices	
Connection	at the terminals of the I.S. isolators (specification see “signal loops”)
Number of channels	16
Connection Safety instrumented system	(X01, X02)
Connection	2 x plug 40 pole for KS1 with STK4A or YUC 40 cable
Number of channels	up to 16 (additional 16 redundant channels available)
HART interface	
Connector X1	HART connector 14 pole (to HART Multiplexer type 9192/32 or to first pac- Carrier)
Connector X2	HART connector optional to second pac- Carrier
Error messaging	(X31)
Power supply failure PF	Contact (35 V / 100 mA), closed in good conditions
Line fault LF (of ISpac modules)	Contact (35 V / 100 mA), closed in good conditions
Setting switch „SP“	Power failure message suppressed for redundant supply (single supply)
Setting switch „LFS“	Line fault message suppressed
Ambient conditions	
Ambient temperature	max. - 20 °C ... + 70 °C (see specification of the I.S. isolators)
Storage temperature	- 40 °C ... + 80 °C
Relative humidity (no condensation)	≤ 95 %
Mechanical data	
Weight	approx. 320 g
Mounting type	on DIN rail (NS35 / 15, NS35 / 7.5) or mounting plate (4 x screw M6)
Mounting position	horizontal or vertical
Casing / Terminal protection class	IP 00 / IP 20
Casing material	PA 6.6
Fire protecting class (UL-94)	V0

Signal loops

The diagrams below show typical applications. Please refer to the connection list to get the entire connection scheme. Basic technical parameters of the ISpac isolating repeaters can be found at the end of this document. The detailed specifications can be downloaded at: www.ispac.info.

Transmitter supply unit (AI)

for 2-, 3-wire transmitter and mA-sources for 2-wire transmitter with HART

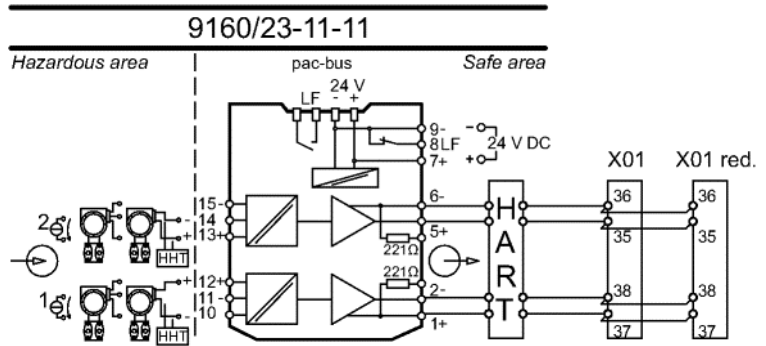



05345E02

Transmitter supply unit (AI)

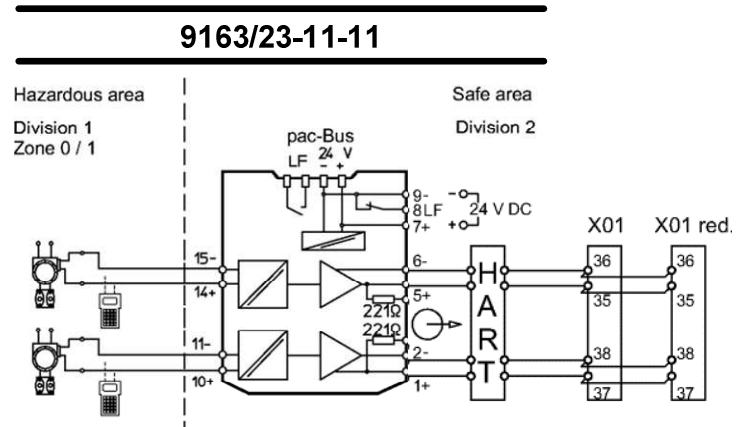
for 4-wire transmitter and mA-sources bi-directional HART communication



Accessories and Spare Parts

Designation	Illustration	Description	Order number
Non-Ex i Termination Module	 06314E00	The termination module is used to integrate non-Ex i field circuit into the system integration solution pac-Carrier type 9195. In such a way it enables a flexible mixture of Ex i and non-Ex i field circuits.	9191/20-00-50s
HART-Multiplexer	 09731E00	<ul style="list-style-type: none"> Used for digital connection of up to 32 HART-capable field devices to an HART management system Installation possible in Zone 2 and Div. 2 Can be used up to SIL 3 (IEC 61508) The Device DTM is used to transmit HART information between HART compatible field devices and a FDT frame application such as Fieldmate 	9192/32-10-10
Fuse		Fuse T2,000A 250 V TR5. Minimum order is 10 pieces	111336

Dimension drawings (all dimensions in mm) - subject to alterations

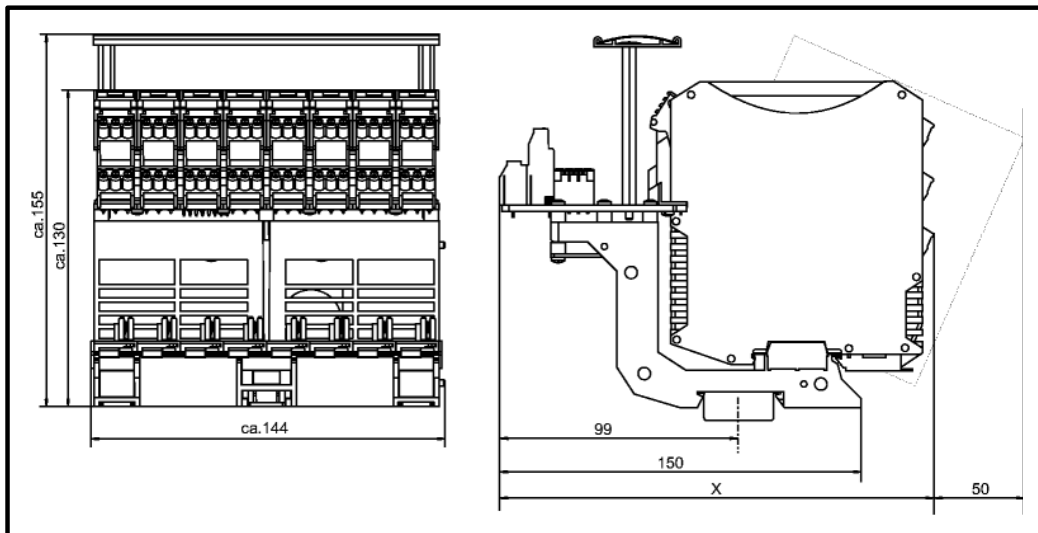

05177E00

	Dimension x
Screw terminals	176 mm
Cage clamp terminals	186 mm

Please note: In order to snap in the ISpac modules an extra space of approx. 50 mm is required. Please read the "ISpac Cabinet installation guide" carefully before you start to engineer the enclosures with incorporated ISpac modules with or without pac-Carriers. The "ISpac Cabinet installation guide" can be downloaded from: www.ispac.info.



Connection list

terminal I.S. *)		channel	carrier slot	input no.	pin X01 (STK4A + KS1)		pin X01 red. (STK4A + KS1)	
10	+	1	1	1	+	37	+	37
11	-				-	38	-	38
14	+	2		2	+	35	+	35
15	-				-	36	-	36
10	+	3	2	3	+	33	+	33
11	-				-	34	-	34
14	+	4		4	+	31	+	31
15	-				-	32	-	32
10	+	5	3	5	+	29	+	29
11	-				-	30	-	30
14	+	6		6	+	27	+	27
15	-				-	28	-	28
10	+	7	4	7	+	25	+	25
11	-				-	26	-	26
14	+	8		8	+	23	+	23
15	-				-	24	-	24
10	+	9	5	9	+	21	+	21
11	-				-	22	-	22
14	+	10		10	+	19	+	19
15	-				-	20	-	20
10	+	11	6	11	+	17	+	17
11	-				-	18	-	18
14	+	12		12	+	15	+	15
15	-				-	16	-	16
10	+	13	7	13	+	13	+	13
11	-				-	14	-	14
14	+	14		14	+	11	+	11
15	-				-	12	-	12
10	+	15	8	15	+	9	+	9
11	-				-	10	-	10
14	+	16		16	+	7	+	7
15	-				-	8	-	8

) Different possibilities of field device connections; for further information see manual of 9160/23-11-1 and 9163/23-11-10.



**pac-Carrier
Type 9195/16H-YO3-01V1**

For Yokogawa / ProSafe-RS / SAI 143

- Signal types: 16 x AI
- pac-Carrier for 16 modules, up to 16 signals
- ISpac isolator AI 9160/13-11-1*, 9163/13-11-10 or 9182/10-51-13 can be used
- Connection to HART-management systems
- Customized system cable type KS1 or YUC 40 to SIS
- Redundant power supply with fault signalization contact and exchangeable fuses
- Horizontal or vertical installation
- Simple installation on DIN rail or mounting plate
- Many labeling possibilities
- Fast and secure installation of the isolators without tools
- Comfortable exchange of the isolators with secured ejector mechanism
- Installation possible in Zone 2, Zone 22 (non conductible dust) and Div. 2

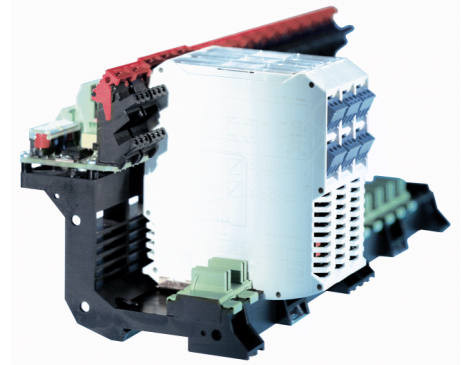

05179E0

Comfortable and simple integration of the I.S. isolators ISpac into Yokogawa / ProSafe-RS Safety instrumented systems via system specific connection boards and system cables.

System overview

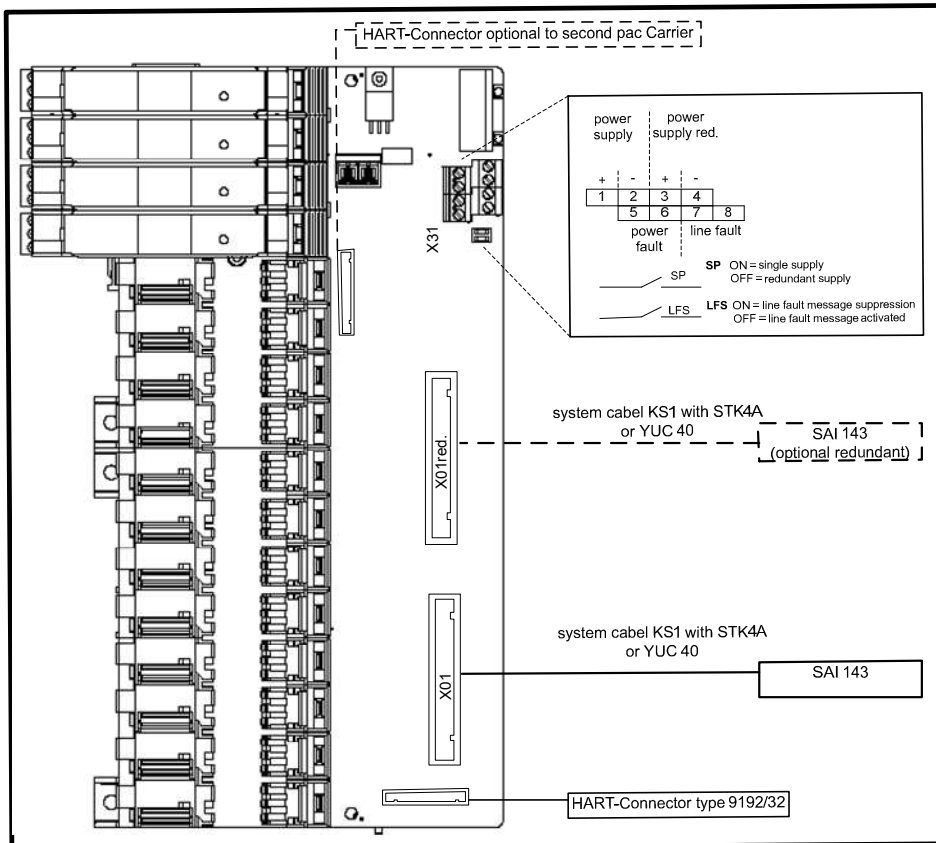

Selection table

Control system				pac-Carrier				
manufacturer	SIS type	I/O Module	Signal type	Slots	HART-MUX	Channels	ISpac type	Type
Yokogawa	ProSafe-RS	SAI 143	16 x AI	16	9192/32	16	9160/13-11-1* 9163/13-11-10	9195/16H-YO3-01V1

Technical data

Certificates	BVS 03 ATEX E213 X
Explosion protection	⊕ II 3 G Ex nA nC II T4
Installation	In Zone 2, Zone 22 (non conductible dust), Div. 2 and in the safe area
Power supply	(X31)
Nominal voltage U_N	24 V DC (19 V ... 31,2 V)
Redundant supply	yes, decoupled with diodes
Indication	2 LED green „PWR1“; „PWR2“
Fuse	2 x TR5; T 2,0 A; exchangeable, for primary and redundant supply
Polarity reversal protection	yes
Connection field devices	
Connection	at the terminals of the I.S. isolators (specification see "signal loops")
Number of channels	16
Connection Safety instrumented system	(X01, X02)
Connection	2 x plug 40 pole for KS1 with STK4A or YUC 40 cable
Number of channels	up to 16 (additional 16 redundant channels available)
HART interface	
Connector X1	HART connector 14 pole (to HART Multiplexer type 9192/32 or to first pac- Carrier)
Connector X2	HART connector optional to second pac- Carrier
Error messaging	(X31)
Power supply failure PF	Contact (35 V / 100 mA), closed in good conditions
Line fault LF (of ISpac modules)	Contact (35 V / 100 mA), closed in good conditions
Setting switch „SP“	Power failure message suppressed for redundant supply (single supply)
Setting switch „LFS“	Line fault message suppressed
Ambient conditions	
Ambient temperature	max. - 20 °C ... + 70 °C (see specification of the I.S. isolators)
Storage temperature	- 40 °C ... + 80 °C
Relative humidity (no condensation)	≤ 95 %
Mechanical data	
Weight	approx. 320 g
Mounting type	on DIN rail (NS35 / 15, NS35 / 7.5) or mounting plate (4 x screw M6)
Mounting position	horizontal or vertical
Casing / Terminal protection class	IP 00 / IP 20
Casing material	PA 6.6
Fire protecting class (UL-94)	V0

Signal loops

The diagrams below show typical applications. Please refer to the connection list to get the entire connection scheme. Basic technical parameters of the ISpac isolating repeaters can be found at the end of this document. The detailed specifications can be downloaded at: www.ispac.info.

Transmitter supply unit (AI)
for 2-, 3-wire transmitter and
mA-sources for 2-wire transmitter with
HART

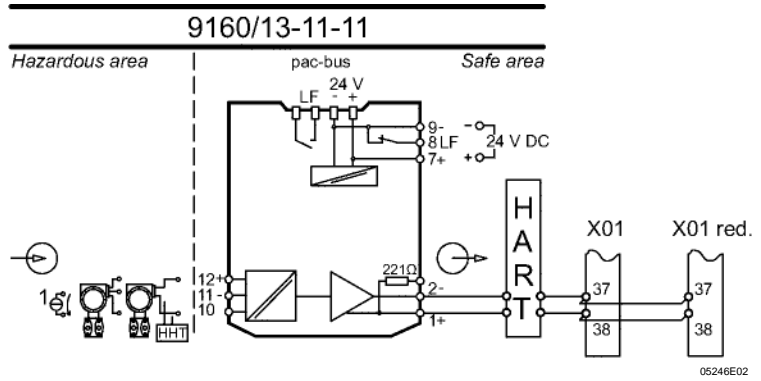

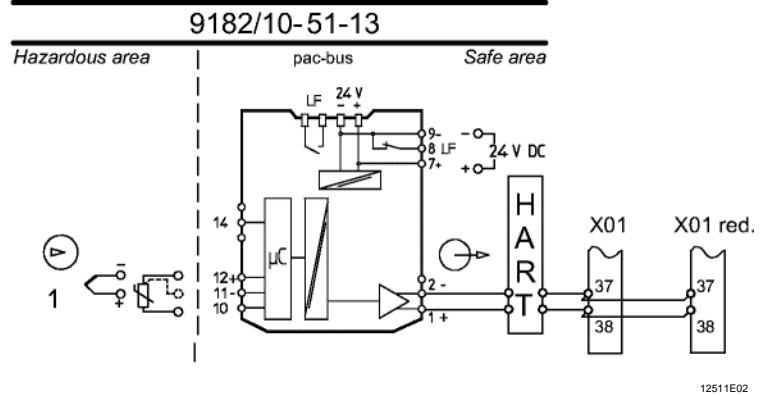

Temperature transmitter (AI)
for resistance thermometer,
thermocouple and RTD
(Configuration ISpac Wizard software)

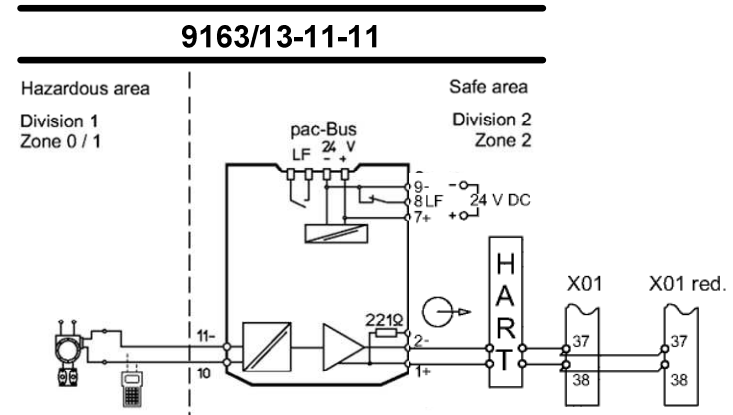

Transmitter supply unit (AI)
for 4-wire transmitter and mA-sources
bi-directional HART communication



Accessories and Spare Parts

Designation	Illustration	Description	Order number
Non-Ex i Termination Module	 06314E00	The termination module is used to integrate non-Ex i field circuit into the system integration solution pac-Carrier type 9195. In such a way it enables a flexible mixture of Ex i and non-Ex i field circuits.	9191/20-00-50s
HART-Multiplexer	 09731E00	<ul style="list-style-type: none"> Used for digital connection of up to 32 HART-capable field devices to an HART management system Installation possible in Zone 2 and Div. 2 Can be used up to SIL 3 (IEC 61508) The Device DTM is used to transmit HART information between HART compatible field devices and a FDT frame application such as Fieldmate 	9192/32-10-10
Fuse		Fuse T2,000A 250 V TR5. Minimum order is 10 pieces	111336

Dimension drawings (all dimensions in mm) - subject to alterations

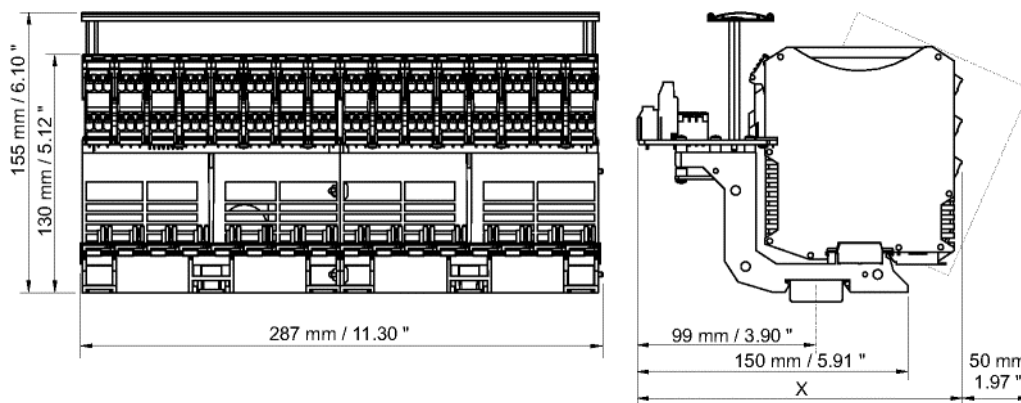

05178E00

	Dimension x
Screw terminals	176 mm
Cage clamp terminals	186 mm

Please note: In order to snap in the ISpac modules an extra space of approx. 50 mm is required. Please read the "ISpac Cabinet installation guide" carefully before you start to engineer the enclosures with incorporated ISpac modules with or without pac-Carriers. The "ISpac Cabinet installation guide" can be downloaded from: www.ispac.info.



Connection list

terminal I.S. *)		channel	carrier slot	input no.	pin X01 (STK4A + KS1)		pin X01 red. (STK4A + KS1)	
10	+	1	1	1	+	37	+	37
11	-				-	38	-	38
10	+	2	2	2	+	35	+	35
11	-				-	36	-	36
10	+	3	3	3	+	33	+	33
11	-				-	34	-	34
10	+	4	4	4	+	31	+	31
11	-				-	32	-	32
10	+	5	5	5	+	29	+	29
11	-				-	30	-	30
10	+	6	6	6	+	27	+	27
11	-				-	28	-	28
10	+	7	7	7	+	25	+	25
11	-				-	26	-	26
10	+	8	8	8	+	23	+	23
11	-				-	24	-	24
10	+	9	9	9	+	21	+	21
11	-				-	22	-	22
10	+	10	10	10	+	19	+	19
11	-				-	20	-	20
10	+	11	11	11	+	17	+	17
11	-				-	18	-	18
10	+	12	12	12	+	15	+	15
11	-				-	16	-	16
10	+	13	13	13	+	13	+	13
11	-				-	14	-	14
10	+	14	14	14	+	11	+	11
11	-				-	12	-	12
10	+	15	15	15	+	9	+	9
11	-				-	10	-	10
10	+	16	16	16	+	7	+	7
11	-				-	8	-	8

) Different possibilities of field device connections; for further information see manual of 9160/13-11-1 or 9182/10-51-13 or 9163/13-11-10.



**pac-Carrier
Type 9195/08H-YO3-02V1**

For Yokogawa / ProSafe-RS / SAV 144

- Signal types: 16 x AI
- pac-Carrier for 8 modules, up to 16 signals
- ISpac isolator AI 9160/23-11-1* and 9163/23-11-10 can be used
- Connection to HART-management systems
- Customized system cable type KS1 and adapter ATK4A or YUC 40 to SIS
- Redundant power supply with fault signalization contact and exchangeable fuses
- Horizontal or vertical installation
- Simple installation on DIN rail or mounting plate
- Many labeling possibilities
- Fast and secure installation of the isolators without tools
- Comfortable exchange of the isolators with secured ejector mechanism
- Installation possible in Zone 2, Zone 22 (non conductible dust) and Div. 2

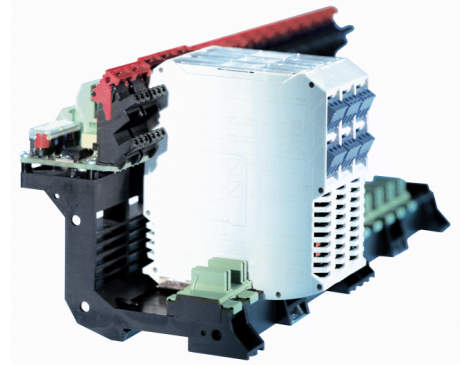

05179E0

Comfortable and simple integration of the I.S. isolators ISpac into Yokogawa / ProSafe-RS Safety instrumented systems via system specific connection boards and system cables.

System overview

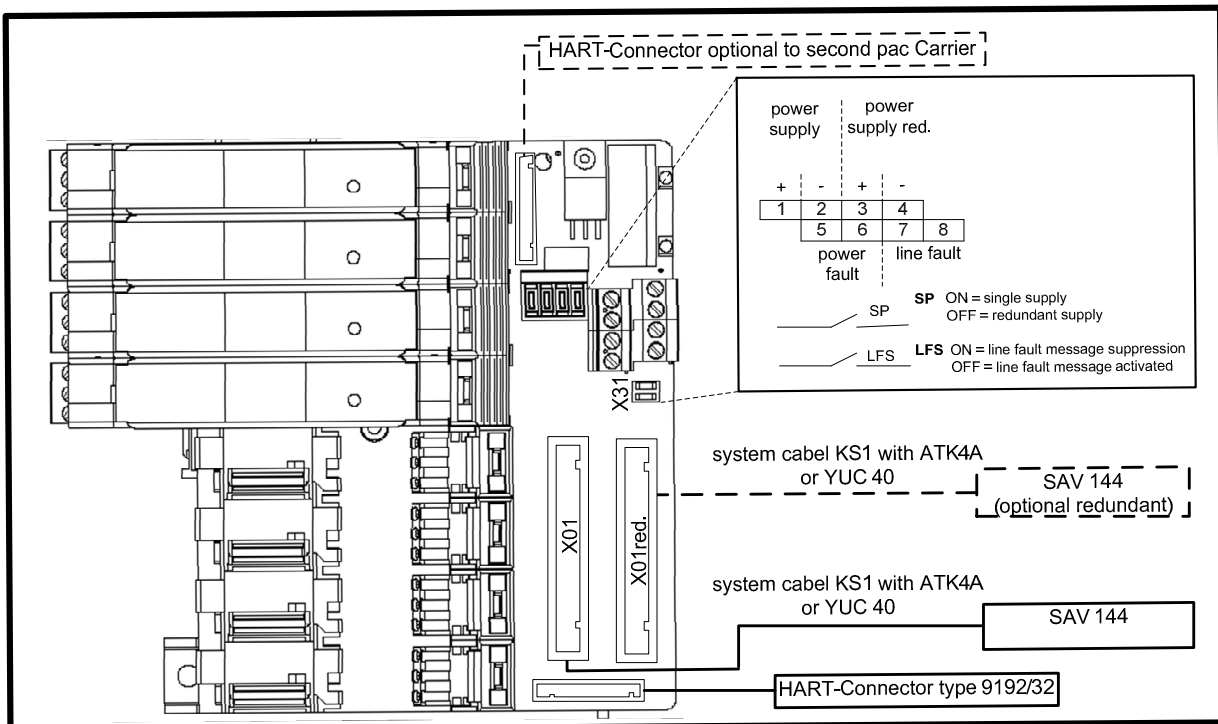

Selection table

Control system				pac-Carrier				
manufacturer	SIS type	I/O Module	Signal type	Slots	HART-MUX	Channels	ISpac type	Type
Yokogawa	ProSafe-RS	SAI 144	16 x AI	8	9192/32	16	9160/23-11-1* 9163/23-11-10	9195/08H-YO3-02V1

Technical data

Certificates	BVS 03 ATEX E213 X
Explosion protection	⊕ II 3 G Ex nA nC II T4
Installation	In Zone 2, Zone 22 (non conductible dust), Div. 2 and in the safe area
Power supply	(X31)
Nominal voltage U_N	24 V DC (19 V ... 31,2 V)
Redundant supply	yes, decoupled with diodes
Indication	2 LED green „PWR1“; „PWR2“
Fuse	2 x TR5; T 2,0 A; exchangeable, for primary and redundant supply
Polarity reversal protection	yes
Connection field devices	
Connection	at the terminals of the I.S. isolators (specification see "signal loops")
Number of channels	16
Connection Safety instrumented system	(X01, X02)
Connection	2 x plug 40 pole for KS1 with ATK4A or YUC 40 cable
Number of channels	up to 16 (additional 16 redundant channels available)
HART interface	
Connector X1	HART connector 14 pole (to HART Multiplexer type 9192/32 or to first pac- Carrier)
Connector X2	HART connector optional to second pac- Carrier
Error messaging	(X31)
Power supply failure PF	Contact (35 V / 100 mA), closed in good conditions
Line fault LF (of ISpac modules)	Contact (35 V / 100 mA), closed in good conditions
Setting switch „SP“	Power failure message suppressed for redundant supply (single supply)
Setting switch „LFS“	Line fault message suppressed
Ambient conditions	
Ambient temperature	max. - 20 °C ... + 70 °C (see specification of the I.S. isolators)
Storage temperature	- 40 °C ... + 80 °C
Relative humidity (no condensation)	≤95 %
Mechanical data	
Weight	approx. 320 g
Mounting type	on DIN rail (NS35 / 15, NS35 / 7.5) or mounting plate (4 x screw M6)
Mounting position	horizontal or vertical
Casing / Terminal protection class	IP 00 / IP 20
Casing material	PA 6.6
Fire protecting class (UL-94)	V0

Signal loops

The diagrams below show typical applications. Please refer to the connection list to get the entire connection scheme. Basic technical parameters of the ISpac isolating repeaters can be found at the end of this document. The detailed specifications can be downloaded at: www.ispac.info.

Transmitter supply unit (AI)

for 2-, 3-wire transmitter and mA-sources for 2-wire transmitter with HART

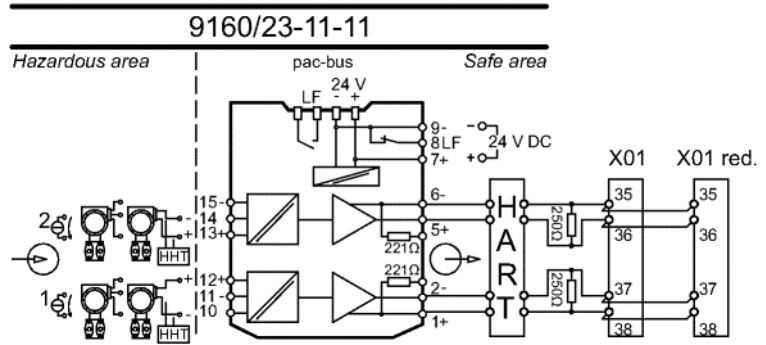



05345E02

Transmitter supply unit (AI)

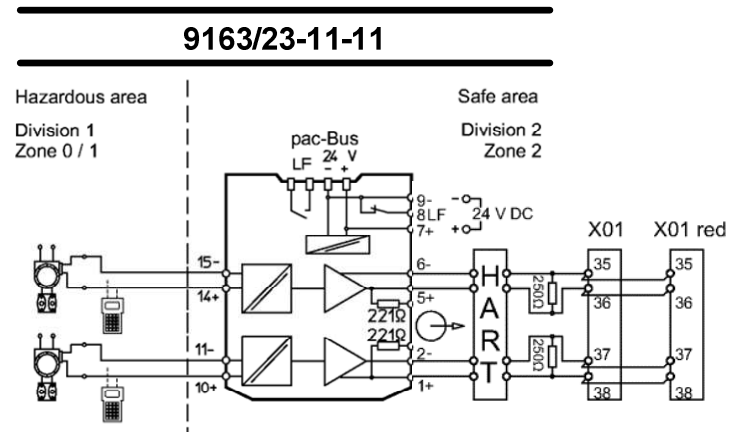
for 4-wire transmitter and mA-sources bi-directional HART communication



Accessories and Spare Parts

Designation	Illustration	Description	Order number
Non-Ex i Termination Module	 06314E00	The termination module is used to integrate non-Ex i field circuit into the system integration solution pac-Carrier type 9195. In such a way it enables a flexible mixture of Ex i and non-Ex i field circuits.	9191/20-00-50s
HART-Multiplexer	 09731E00	<ul style="list-style-type: none"> Used for digital connection of up to 32 HART-capable field devices to an HART management system Installation possible in Zone 2 and Div. 2 Can be used up to SIL 3 (IEC 61508) The Device DTM is used to transmit HART information between HART compatible field devices and a FDT frame application such as Fieldmate 	9192/32-10-10
Fuse		Fuse T2,000A 250 V TR5. Minimum order is 10 pieces	111336

Dimension drawings (all dimensions in mm) - subject to alterations

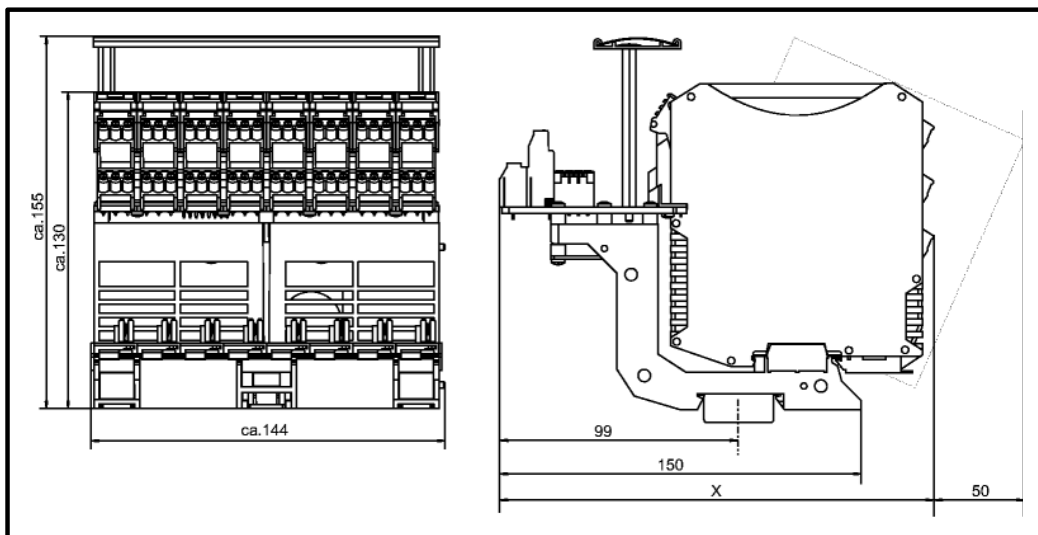

05177E00



	Dimension x
Screw terminals	176 mm
Cage clamp terminals	186 mm

Please note: In order to snap in the ISpac modules an extra space of approx. 50 mm is required. Please read the "ISpac Cabinet installation guide" carefully before you start to engineer the enclosures with incorporated ISpac modules with or without pac-Carriers. The "ISpac Cabinet installation guide" can be downloaded from: www.ispac.info.

Connection list

terminal I.S. *)		channel	carrier slot	input no.	pin X01 (STK4A + KS1)		pin X01 red. (STK4A + KS1)	
10	+	1	1	1	+	38	+	38
11	-				-	37	-	37
14	+	2		2	+	36	+	36
15	-				-	35	-	35
10	+	3	2	3	+	34	+	34
11	-				-	33	-	33
14	+	4		4	+	32	+	32
15	-				-	31	-	31
10	+	5	3	5	+	30	+	30
11	-				-	29	-	29
14	+	6		6	+	28	+	28
15	-				-	27	-	27
10	+	7	4	7	+	26	+	26
11	-				-	25	-	25
14	+	8		8	+	24	+	24
15	-				-	23	-	23
10	+	9	5	9	+	22	+	22
11	-				-	21	-	21
14	+	10		10	+	20	+	20
15	-				-	19	-	19
10	+	11	6	11	+	18	+	18
11	-				-	17	-	17
14	+	12		12	+	16	+	16
15	-				-	15	-	15
10	+	13	7	13	+	14	+	14
11	-				-	13	-	13
14	+	14		14	+	12	+	12
15	-				-	11	-	11
10	+	15	8	15	+	10	+	10
11	-				-	9	-	9
14	+	16		16	+	8	+	8
15	-				-	7	-	7

) Different possibilities of field device connections; for further information see manual of 9160/23-11-1 or 9163/23-11-10.



**pac-Carrier
Type 9195/16H-YO3-02V1**

For Yokogawa / ProSafe-RS / SAI 143

- Signal types: 16 x AI
- pac-Carrier for 16 modules, up to 16 signals
- ISpac isolator AI 9160/13-11-1* or 9163/13-11-10 or 9182/10-51-13 can be used
- Connection to HART-management systems
- Customized system cable type KS1 and adapter ATK4A or YUC 40 to SIS
- Redundant power supply with fault signalization contact and exchangeable fuses
- Horizontal or vertical installation
- Simple installation on DIN rail or mounting plate
- Many labeling possibilities
- Fast and secure installation of the isolators without tools
- Comfortable exchange of the isolators with secured ejector mechanism
- Installation possible in Zone 2, Zone 22 (non conductible dust) and Div. 2

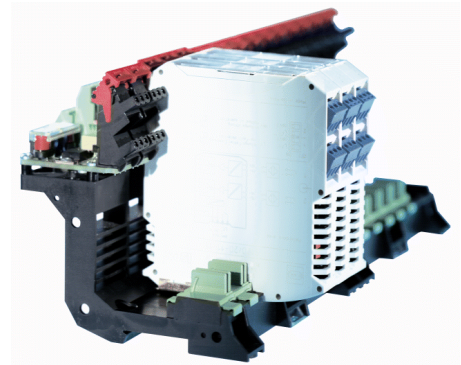

05179E0

Comfortable and simple integration of the I.S. isolators ISpac into Yokogawa / ProSafe-RS Safety instrumented systems via system specific connection boards and system cables.

System overview

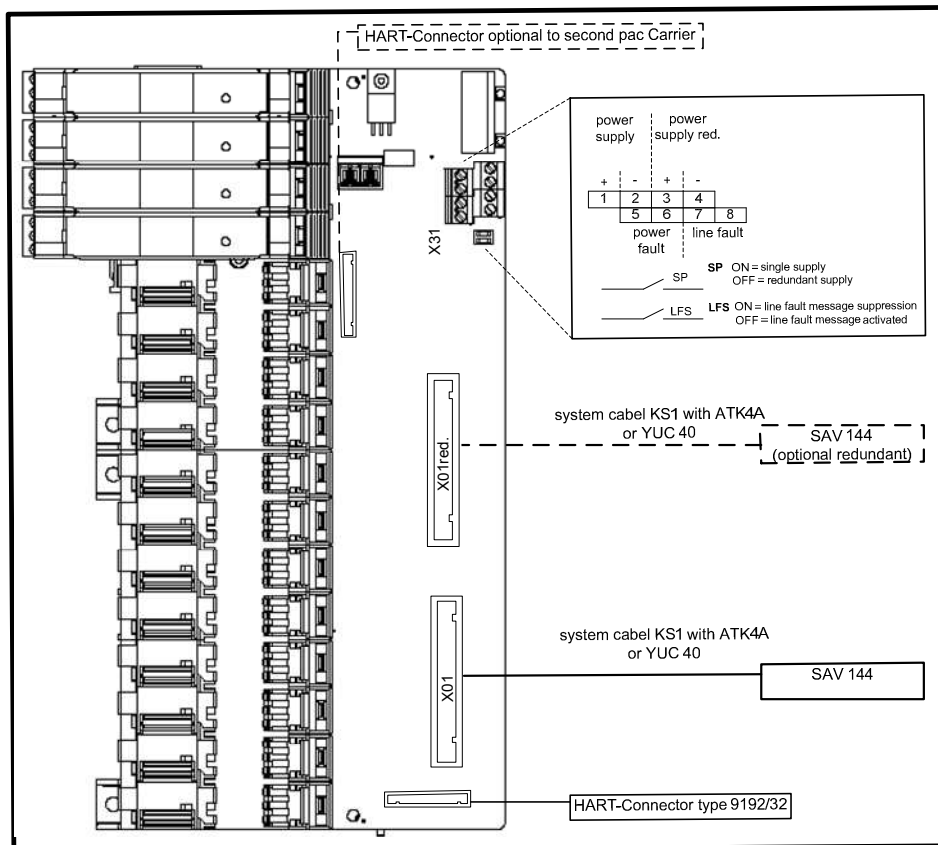

Selection table

Control system				pac-Carrier				
manufacturer	SIS type	I/O Module	Signal type	Slots	HART-MUX	Channels	ISpac type	Type
Yokogawa	ProSafe-RS	SAV 144	16 x AI	16	9192/32	16	9160/13-11-1* 9163/13-11-10 9182/10-51-13	9195/16H-YO3-02V1

Technical data

Certificates	BVS 03 ATEX E213 X
Explosion protection	⊕ II 3 G Ex nA nC II T4
Installation	In Zone 2, Zone 22 (non conductible dust), Div. 2 and in the safe area
Power supply	(X31)
Nominal voltage U_N	24 V DC (19 V ... 31,2 V)
Redundant supply	yes, decoupled with diodes
Indication	2 LED green „PWR1“, „PWR2“
Fuse	2 x TR5; T 2,0 A; exchangeable, for primary and redundant supply
Polarity reversal protection	yes
Connection field devices	
Connection	at the terminals of the I.S. isolators (specification see “signal loops”)
Number of channels	16
Connection Safety instrumented system	(X01, X02)
Connection	2 x plug 40 pole for KS1 with ATK4A or YUC 40 cable
Number of channels	up to 16 (additional 16 redundant channels available)
HART interface	
Connector X1	HART connector 14 pole (to HART Multiplexer type 9192/32 or to first pac- Carrier)
Connector X2	HART connector optional to second pac- Carrier
Error messaging	(X31)
Power supply failure PF	Contact (35 V / 100 mA), closed in good conditions
Line fault LF (of ISpac modules)	Contact (35 V / 100 mA), closed in good conditions
Setting switch „SP“	Power failure message suppressed for redundant supply (single supply)
Setting switch „LFS“	Line fault message suppressed
Ambient conditions	
Ambient temperature	max. - 20 °C ... + 70 °C (see specification of the I.S. isolators)
Storage temperature	- 40 °C ... + 80 °C
Relative humidity (no condensation)	≤ 95 %
Mechanical data	
Weight	approx. 320 g
Mounting type	on DIN rail (NS35 / 15, NS35 / 7.5) or mounting plate (4 x screw M6)
Mounting position	horizontal or vertical
Casing / Terminal protection class	IP 00 / IP 20
Casing material	PA 6.6
Fire protecting class (UL-94)	V0

Signal loops

The diagrams below show typical applications. Please refer to the connection list to get the entire connection scheme. Basic technical parameters of the ISpac isolating repeaters can be found at the end of this document. The detailed specifications can be downloaded at: www.ispac.info.

Transmitter supply unit (AI)
for 2-, 3-wire transmitter and
mA-sources for 2-wire transmitter with
HART

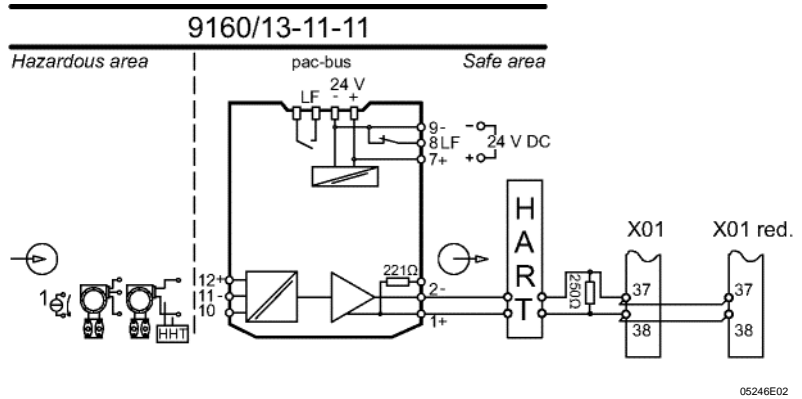

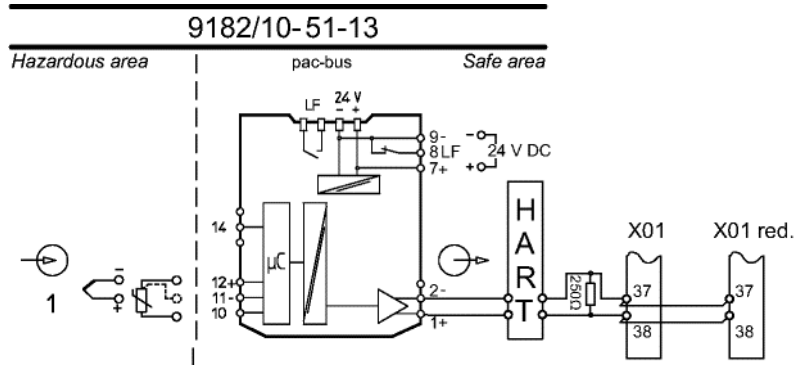

Temperature transmitter (AI)
for resistance thermometer,
thermocouple and RTD
(Configuration ISpac Wizard software)

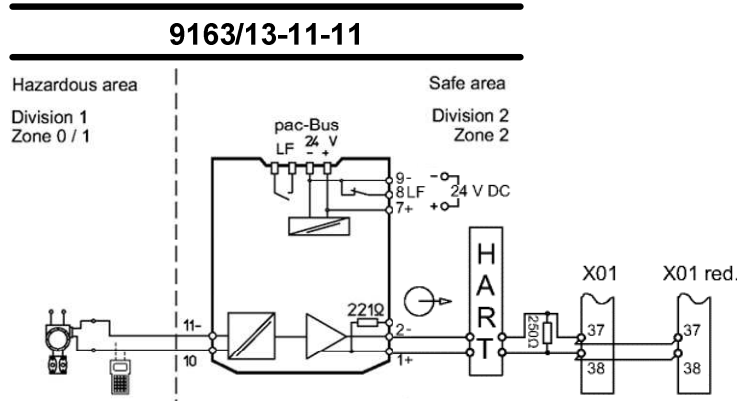

Transmitter supply unit (AI)
for 4-wire transmitter and mA-sources
bi-directional HART communication



Accessories and Spare Parts			
Designation	Illustration	Description	Order number
Non-Ex i Termination Module	 06314E00	The termination module is used to integrate non-Ex i field circuit into the system integration solution pac-Carrier type 9195. In such a way it enables a flexible mixture of Ex i and non-Ex i field circuits.	9191/20-00-50s
HART-Multiplexer	 09731E00	<ul style="list-style-type: none"> Used for digital connection of up to 32 HART-capable field devices to an HART management system Installation possible in Zone 2 and Div. 2 Can be used up to SIL 3 (IEC 61508) The Device DTM is used to transmit HART information between HART compatible field devices and a FDT frame application such as Fieldmate 	9192/32-10-10
Fuse		Fuse T2,000A 250 V TR5. Minimum order is 10 pieces	111336

Dimension drawings (all dimensions in mm) - subject to alterations

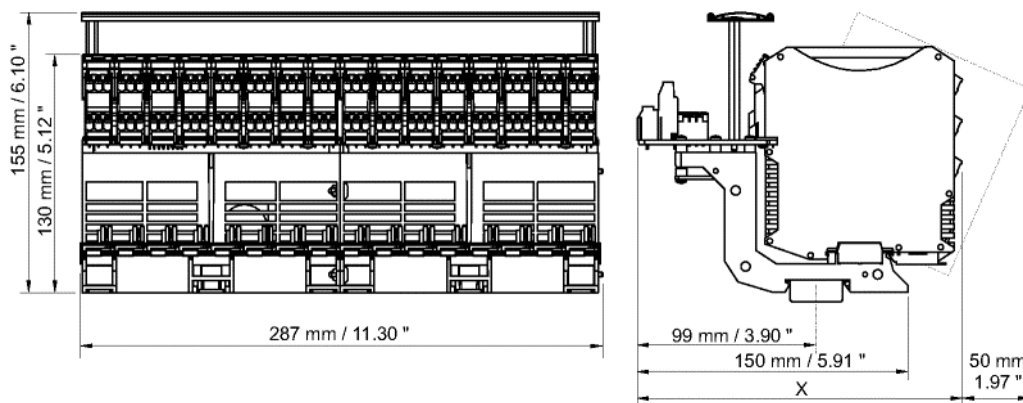

05178E00

	Dimension x
Screw terminals	176 mm
Cage clamp terminals	186 mm

Please note: In order to snap in the ISpac modules an extra space of approx. 50 mm is required. Please read the "ISpac Cabinet installation guide" carefully before you start to engineer the enclosures with incorporated ISpac modules with or without pac-Carriers. The "ISpac Cabinet installation guide" can be downloaded from: www.ispac.info.



Connection list

terminal I.S. *)		channel	carrier slot	input no.	pin X01 (STK4A + KS1)		pin X01 red. (STK4A + KS1)	
10	+	1	1	1	+	38	+	38
11	-				-	37	-	37
10	+	2	2	2	+	36	+	36
11	-				-	35	-	35
10	+	3	3	3	+	34	+	34
11	-				-	33	-	33
10	+	4	4	4	+	32	+	32
11	-				-	31	-	31
10	+	5	5	5	+	30	+	30
11	-				-	29	-	29
10	+	6	6	6	+	28	+	28
11	-				-	27	-	27
10	+	7	7	7	+	26	+	26
11	-				-	25	-	25
10	+	8	8	8	+	24	+	24
11	-				-	23	-	23
10	+	9	9	9	+	22	+	22
11	-				-	21	-	21
10	+	10	10	10	+	20	+	20
11	-				-	19	-	19
10	+	11	11	11	+	18	+	18
11	-				-	17	-	17
10	+	12	12	12	+	16	+	16
11	-				-	15	-	15
10	+	13	13	13	+	14	+	14
11	-				-	13	-	13
10	+	14	14	14	+	12	+	12
11	-				-	11	-	11
10	+	15	15	15	+	10	+	10
11	-				-	9	-	9
10	+	16	16	16	+	8	+	8
11	-				-	7	-	7

) Different possibilities of field device connections; for further information see manual of 9160/13-11-1, 9163/13-11-10 or 9182/10-51-13.



**pac-Carrier
Type 9195/08H-YO3-06V1**

For Yokogawa / ProSafe-RS / SAI 533

- Signal types: 8 x AO
- pac-Carrier for 8 modules, up to 8 signals
- ISpac isolator AI 9165/16-11-11 or 9167/1*-11-00 can be used
- Connection to HART-management systems
- Customized system cable type KS1 and adapter STK4A or YUC 40 to SIS
- Redundant power supply with fault signalization contact and exchangeable fuses
- Horizontal or vertical installation
- Simple installation on DIN rail or mounting plate
- Many labeling possibilities
- Fast and secure installation of the isolators without tools
- Comfortable exchange of the isolators with secured ejector mechanism
- Installation possible in Zone 2, Zone 22 (non conductible dust) and Div. 2

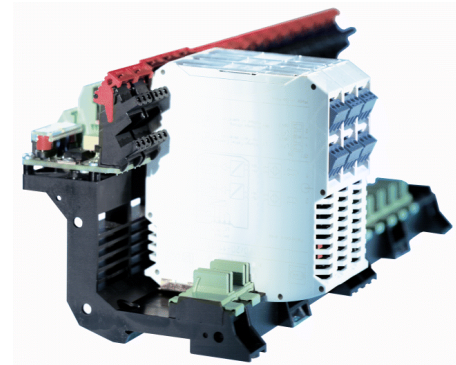

05179E0

Comfortable and simple integration of the I.S. isolators ISpac into Yokogawa / ProSafe-RS Safety instrumented systems via system specific connection boards and system cables.

System overview

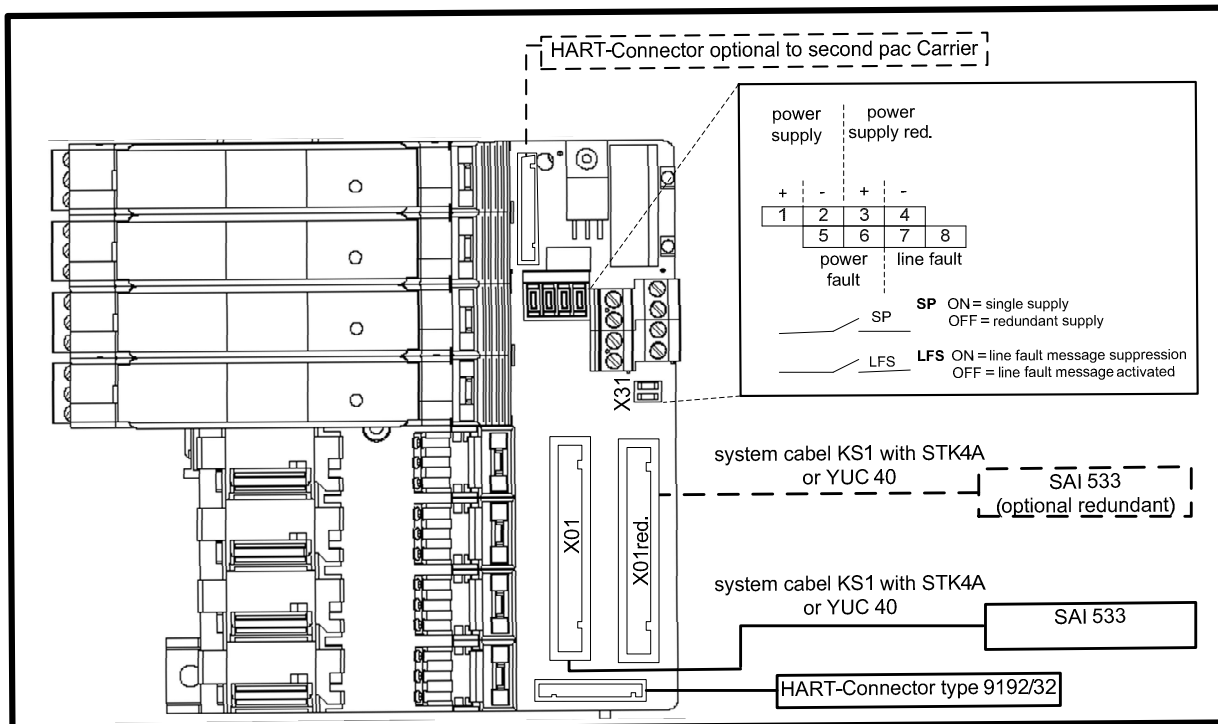

Selection table

Control system				pac-Carrier				
manufacturer	SIS type	I/O Module	Signal type	Slots	HART-MUX	Channels	ISpac type	Type
Yokogawa	ProSafe-RS	SAI 533	8 x AI	8	9192/32	8	9165/16-11-11 9167/1*-11-00	9195/08H-YO3-06V1

Technical data

Certificates	BVS 03 ATEX E213 X
Explosion protection	⊕ II 3 G Ex nA nC II T4
Installation	In Zone 2, Zone 22 (non conductible dust), Div. 2 and in the safe area
Power supply	(X31)
Nominal voltage U _N	24 V DC (19 V ... 31,2 V)
Redundant supply	yes, decoupled with diodes
Indication	2 LED green „PWR1“; „PWR2“
Fuse	2 x TR5; T 2,0 A; exchangeable, for primary and redundant supply
Polarity reversal protection	yes
Connection field devices	
Connection	at the terminals of the I.S. isolators (specification see "signal loops")
Number of channels	8
Connection Safety instrumented system	(X01, X02)
Connection	2 x plug 40 pole for KS1 with ATK4A or YUC 40 cable
Number of channels	up to 8 (additional 8 redundant channels available)
HART interface	
Connector X1	HART connector 14 pole (to HART Multiplexer type 9192/32 or to first pac- Carrier)
Connector X2	HART connector optional to second pac- Carrier
Error messaging	(X31)
Power supply failure PF	Contact (35 V / 100 mA), closed in good conditions
Line fault LF (of ISpac modules)	Contact (35 V / 100 mA), closed in good conditions
Setting switch „SP“	Power failure message suppressed for redundant supply (single supply)
Setting switch „LFS“	Line fault message suppressed
Ambient conditions	
Ambient temperature	max. - 20 °C ... + 70 °C (see specification of the I.S. isolators)
Storage temperature	- 40 °C ... + 80 °C
Relative humidity (no condensation)	≤95 %
Mechanical data	
Weight	approx. 320 g
Mounting type	on DIN rail (NS35 / 15, NS35 / 7.5) or mounting plate (4 x screw M6)
Mounting position	horizontal or vertical
Casing / Terminal protection class	IP 00 / IP 20
Casing material	PA 6.6
Fire protecting class (UL-94)	V0

Signal loops

The diagrams below show typical applications. Please refer to the connection list to get the entire connection scheme. Basic technical parameters of the ISpac isolating repeaters can be found at the end of this document. The detailed specifications can be downloaded at: www.ispac.info.

Isolating repeater (AO)

for control valves, i/p-converters or indicators
bi-directional HART communication

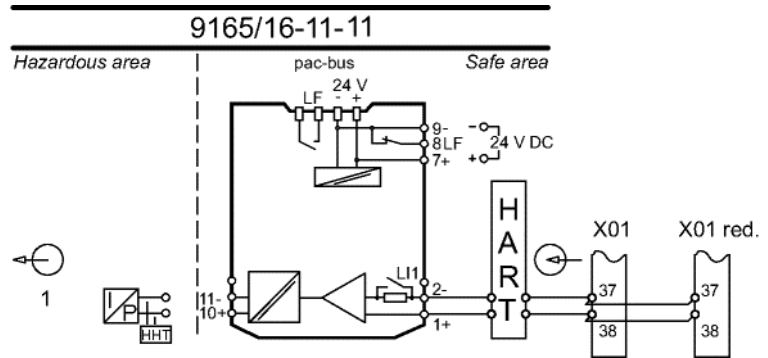

Isolating repeater (AO)

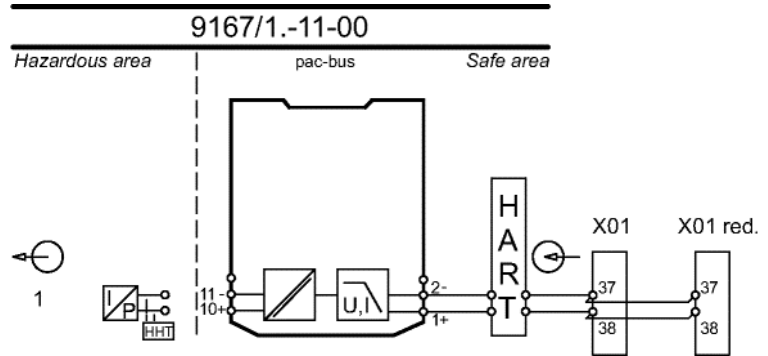

Loop-powered, for control valves, i/p-converters or indicators
bi-directional HART communication



05268E02



Accessories and Spare Parts

Designation	Illustration	Description	Order number
Non-Ex i Termination Module	 06314E00	The termination module is used to integrate non-Ex i field circuit into the system integration solution pac-Carrier type 9195. In such a way it enables a flexible mixture of Ex i and non-Ex i field circuits.	9191/20-00-50s
HART-Multiplexer	 09731E00	<ul style="list-style-type: none"> Used for digital connection of up to 32 HART-capable field devices to an HART management system Installation possible in Zone 2 and Div. 2 Can be used up to SIL 3 (IEC 61508) The Device DTM is used to transmit HART information between HART compatible field devices and a FDT frame application such as FieldCare or PactWare™ 	9192/32-10-10
Fuse		Fuse T2,000A 250 V TR5. Minimum order is 10 pieces	111336

Dimension drawings (all dimensions in mm) - subject to alterations

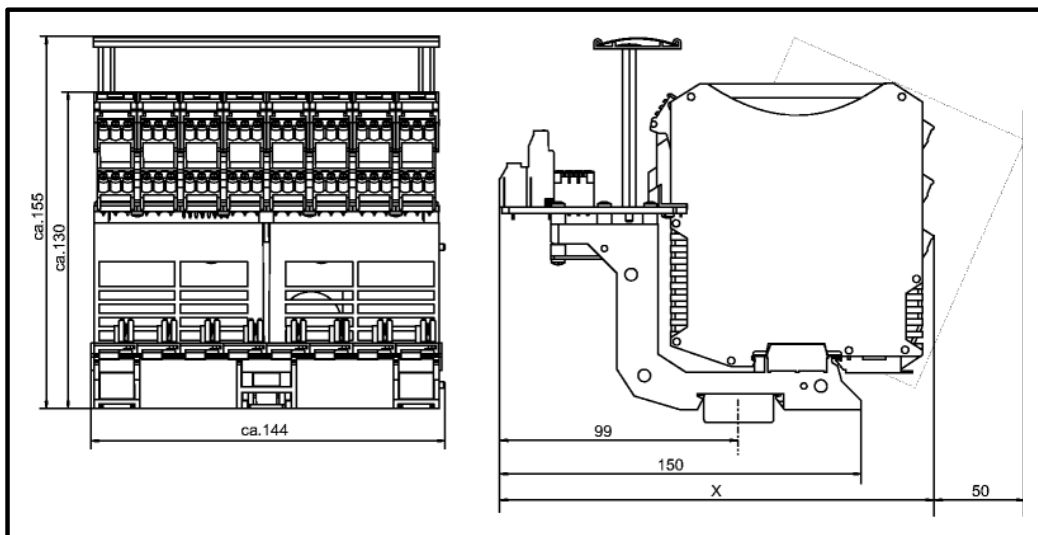

05177E00



	Dimension x
Screw terminals	176 mm
Cage clamp terminals	186 mm

Please note: In order to snap in the ISpac modules an extra space of approx. 50 mm is required. Please read the "ISpac Cabinet installation guide" carefully before you start to engineer the enclosures with incorporated ISpac modules with or without pac-Carriers. The "ISpac Cabinet installation guide" can be downloaded from: www.ispac.info.

Connection list

terminal I.S.		channel	carrier slot	output no.	pin X01 (STK4A + KS1)		pin X01 red. (STK4A + KS1)	
10	+	1	1	1	+	38	+	38
11	-				-	37	-	37
10	+	2	2	2	+	34	+	34
11	-				-	33	-	33
10	+	3	3	3	+	30	+	30
11	-				-	29	-	29
10	+	4	4	4	+	26	+	26
11	-				-	25	-	25
10	+	5	5	5	+	22	+	22
11	-				-	21	-	21
10	+	6	6	6	+	18	+	18
11	-				-	17	-	17
10	+	7	7	7	+	14	+	14
11	-				-	13	-	13
10	+	8	8	8	+	10	+	10
11	-				-	9	-	9

) Different possibilities of field device connections; for further information see manual of 9165/16-11-11 or 9167/1-11-00.



We reserve the right to make alterations to the technical data, weights, dimensions, designs and products available without notice. The illustration cannot be considered binding.



R. STAHL Schaltgeräte GmbH
Am Bahnhof 30, D-74638 Waldenburg, Germany
Telefon +49 7942 943-0
Telefax +49 7942 943-4333
E-Mail: info@stahl.de
Internet: <http://www.stahl.de>